

Screw-in pressure regulators

0821302072

General series information
AVENTICS Series SR1, Screw-in pressure regulators

- Energy-saving valves for direct fitting on the cylinder

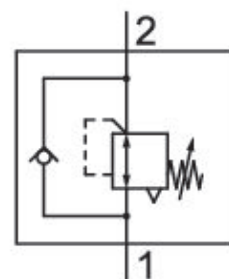

Technical data

Industry	Industrial
Type	Poppet valve
Compressed air connection input	G 1/8
Compressed air connection type input	plug-in with tube nut
Compressed air connection output	Ø 4
Compressed air connection type output	External thread
Working pressure min.	1 bar
Working pressure max	16 bar
Regulation range min.	1 bar
Regulation range max.	8 bar
Min. ambient temperature	-10 °C
Max. ambient temperature	70 °C

Min. medium temperature	-10 °C
Max. medium temperature	70 °C
Medium	Compressed air
Qn 1 > 2	600 l/min
Weight	0.1 kg
Housing material	Brass Polyamide
Surface housing	galvanized
Seal material	Acrylonitrile butadiene rubber
Part No.	0821302072

Technical information

The pressure dew point must be at least 15 °C less than ambient and medium temperature and may not exceed 3 °C.

The min. control pressure must be adhered to, since otherwise faulty switching and valve failure may result!

The pressure dew point must be at least 15 °C less than ambient and medium temperature and may not exceed 3 °C.

The oil content of compressed air must remain constant during the life cycle.

Use only the approved oils from AVENTICS. Further information can be found in the "Technical information" document (available in <https://www.emerson.com/en-us/support>).

0821302074

0821302075

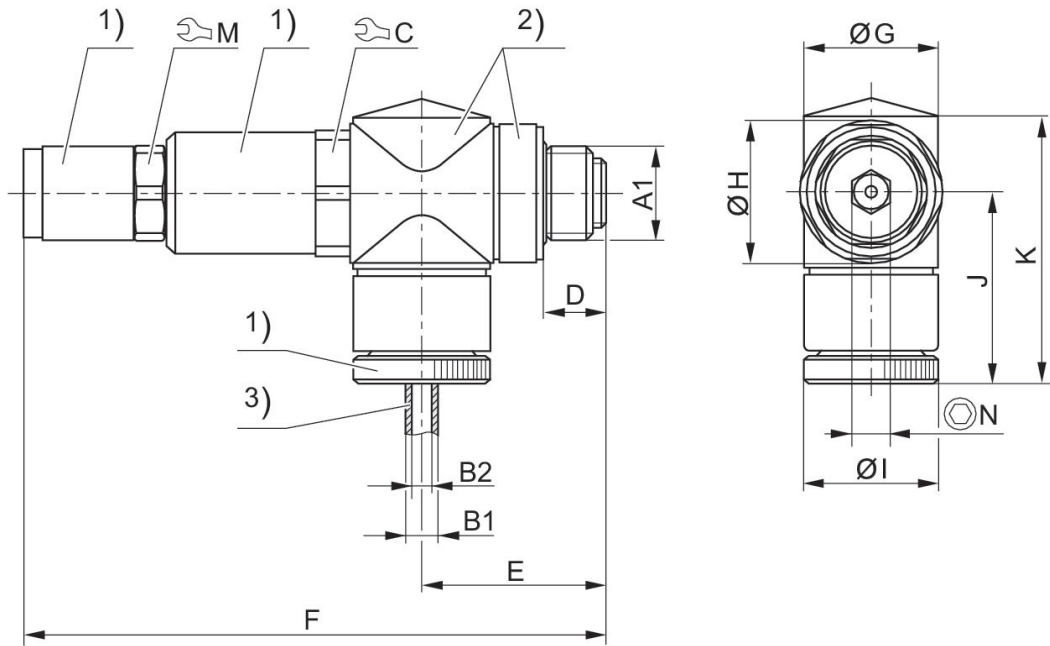

1) galvanized brass 2) polyamide 3) tubing
A1 = input B1 = output

Part No.	A1	B1	B2	C	D	E	F	G	H
0821302074	G 1/4	6	4	17	9.5	25.8	78.8	13	19

Part No.	I	J	K	M	N
0821302074	13	25.5	37.6	13	5

0821302072

0821302073

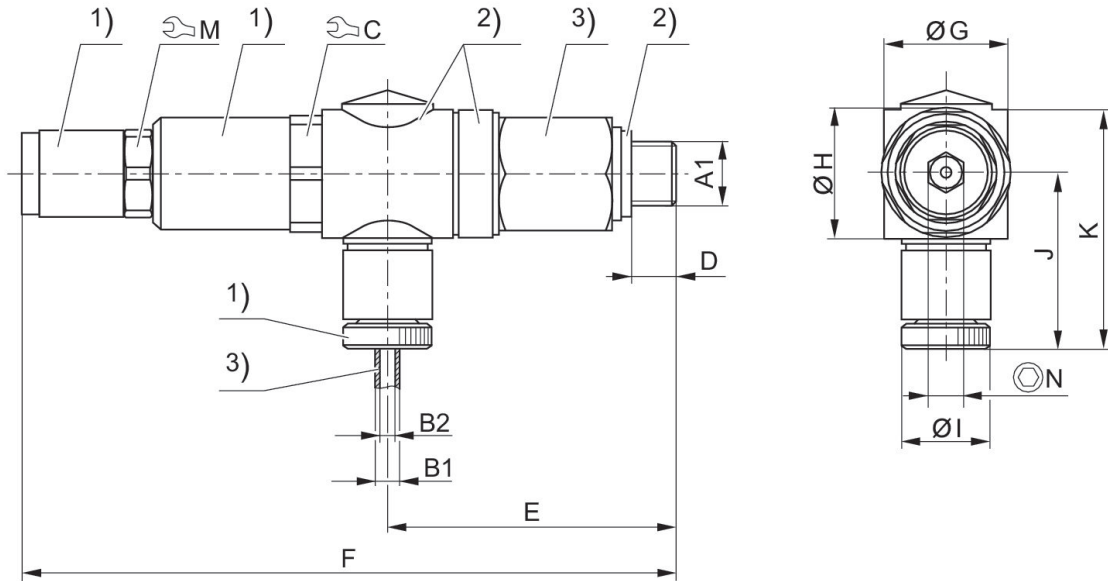

1) galvanized brass 2) polyamide 3) galvanized brass 4) hose
A1 = input B1 = output

Part No.	A1	B1	B2	C	D	E	F	M
0821302072	G 1/8	6	4	17	6.5	42.3	95.3	13

Hysteresis

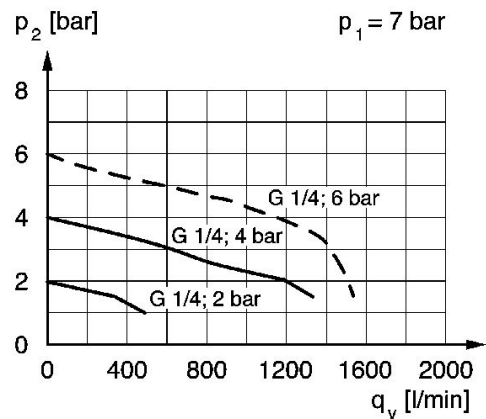
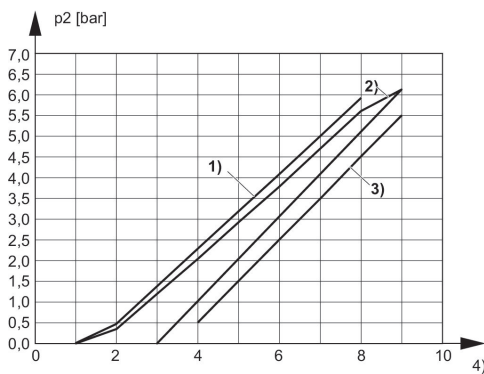

- 1) Overfill hysteresis
- 2) Control hysteresis
- 3) Refill hysteresis
- 4) Adjustment screw rotations

p₁ = working pressure, p₂ = secondary pressure, q_v = nominal flow

Pressure characteristics curve (flow rate from 1 to 2)

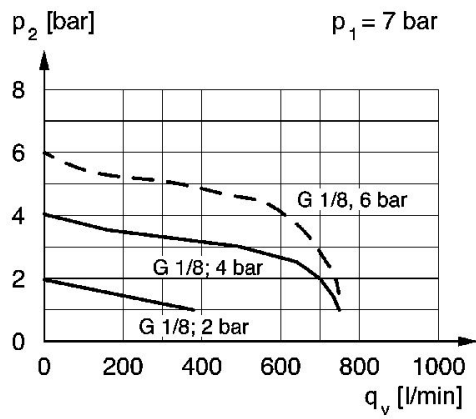

Application example

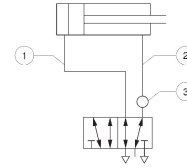

1) e.g. forward stroke with max. pressure 2) return stroke with reduced pressure 3) installation point on directional control valve
At low tightening torque, the sealing ring enables the banjo union to swivel through 360°. Further tightening locks the banjo union into position. Adjust pressure via adjustment screw with hexagon socket. Lock using counter nuts.