

Tie rod cylinder ISO 6431, Series 167

1670225000

General series information
AVENTICS Series 167 Tie-rod cylinder

- The AVENTICS Series 167 is a tie rod cylinder according ISO 6431 and offers the highest robustness for tough environment.



Technical data

| | |
|--|---------------------------------|
| Industry | Industrial |
| Standards | ISO 6431 |
| Piston Ø | 25 mm |
| Stroke | 250 mm |
| Ports | G 1/8 |
| Functional principle | Double-acting |
| Cushioning | Pneumatic adjustable cushioning |
| Magnetic piston | Piston with magnet |
| Environmental requirements | Industry standard |
| Piston rod | single |
| Scraper | Standard Industry Scraper |
| Pressure for determining piston forces | [[8] bar] |
| Retracting piston force | 230 N |
| Extracting piston force | 300 N |

| | |
|------------------------------------|---------------------|
| Min. ambient temperature | -20 °C |
| Max. ambient temperature | 75 °C |
| Working pressure min. | 2 bar |
| Working pressure max | 10 bar |
| Piston rod thread | M10x1,25 |
| Cushioning length | 11 mm |
| Cushioning energy | 2.3 J |
| Weight 0 mm stroke | 0.27 kg |
| Weight +10 mm stroke | 0.018 kg |
| Stroke max. | 1500 mm |
| Medium | Compressed air |
| Min. medium temperature | -20 °C |
| Max. medium temperature | 75 °C |
| Max. particle size | 50 µm |
| Oil content of compressed air min. | 0 mg/m ³ |
| Oil content of compressed air max. | 5 mg/m ³ |

Material

| | |
|-----------------------|--------------------------------|
| Piston rod | Stainless Steel |
| Seal material | Acrylonitrile butadiene rubber |
| Material, front cover | Aluminum |
| Cylinder tube | Aluminum |
| End cover | Aluminum |
| Part No. | 1670225000 |

Technical information

Ø25 mm is not according to ISO 6431

The pressure dew point must be at least 15 °C less than ambient and medium temperature and may not exceed 3 °C.

The oil content of compressed air must remain constant during the life cycle.

Use only the approved oils from AVENTICS. Further information can be found in the “Technical information” document (available in <https://www.emerson.com/en-us/support>).

Dimensions

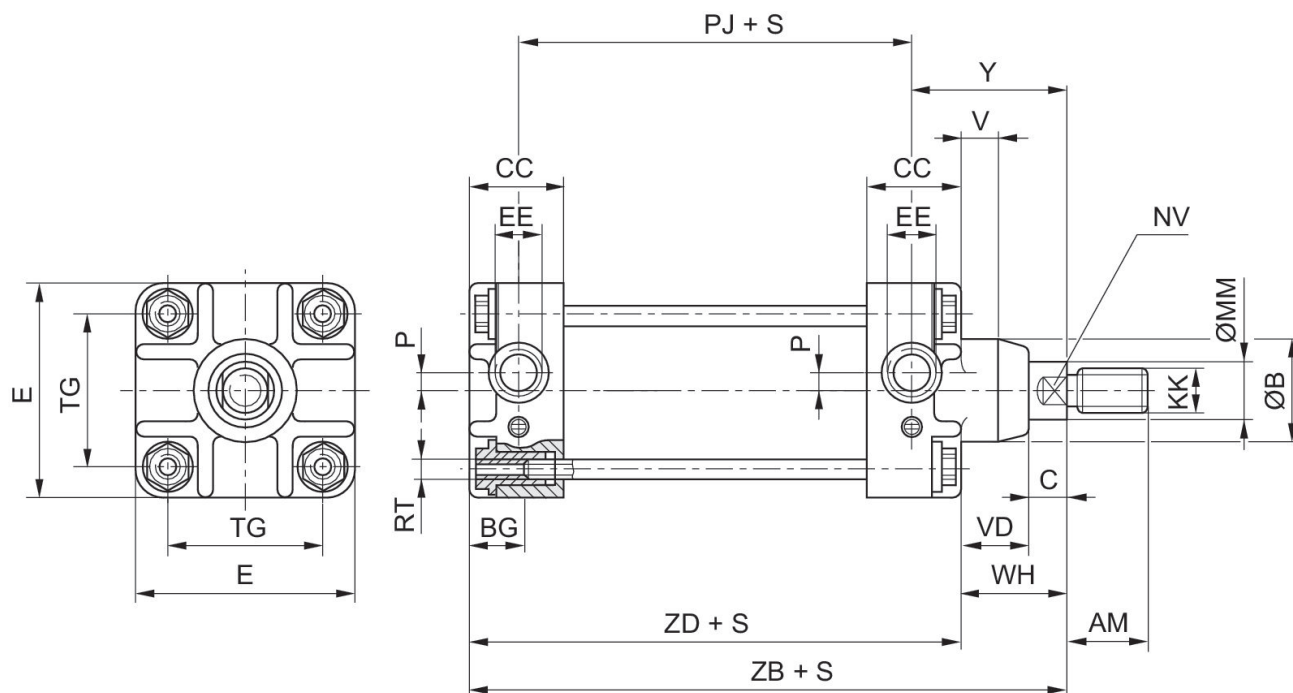

| Piston Ø | AM | Ø B h12 | BG | C | CC | E | EE | KK | Ø MM |
|----------|----|---------|----|----|------|-----|-------|----------|------|
| 25 | 22 | 23 | 12 | 8 | 20,0 | 40 | G 1/8 | M10x1,25 | 12 |
| 32 | 22 | 25 | 12 | 10 | 27,5 | 47 | G 1/8 | M10x1,25 | 12 |
| 40 | 24 | 35 | 15 | 13 | 30,0 | 56 | G 1/4 | M12x1,25 | 16 |
| 50 | 32 | 40 | 15 | 15 | 30,0 | 63 | G 1/4 | M16x1,5 | 20 |
| 63 | 32 | 40 | 19 | 14 | 34,0 | 81 | G 3/8 | M16x1,5 | 20 |
| 80 | 40 | 48 | 19 | 16 | 36,0 | 95 | G 3/8 | M20x1,5 | 25 |
| 100 | 40 | 55 | 23 | 16 | 40,0 | 115 | G 1/2 | M20x1,5 | 25 |

| Piston Ø | NV | P | PJ | RT | TG | V | VD | WH | Y |
|----------|----|----|-----|-----|----|---|----|----|----|
| 25 | 10 | - | 58 | M5 | 27 | - | 16 | 24 | 31 |
| 32 | 10 | 4 | 65 | M5 | 32 | 5 | 16 | 26 | 41 |
| 40 | 13 | 4 | 69 | M6 | 40 | 5 | 20 | 33 | 48 |
| 50 | 17 | 4 | 72 | M6 | 46 | 6 | 23 | 38 | 54 |
| 63 | 17 | 6 | 79 | M8 | 59 | 6 | 27 | 41 | 58 |
| 80 | 22 | 9 | 86 | M8 | 73 | 8 | 32 | 48 | 67 |
| 100 | 22 | 12 | 100 | M10 | 90 | 8 | 37 | 53 | 70 |

| Piston Ø | ZB | ZD | stroke tolerance |
|----------|----------|-----|------------------|
| 25 | 98 ±1,2 | 74 | +2/-1 |
| 32 | 120 ±1,2 | 94 | +2/-0 |
| 40 | 132 ±1,2 | 99 | +2/-0 |
| 50 | 142 ±1,2 | 104 | +2/-0 |
| 63 | 154 ±1,4 | 113 | +2,5/-0 |

| Piston Ø | ZB | ZD | stroke tolerance |
|----------|----------|-----|------------------|
| 80 | 172 ±1,4 | 124 | +2,5/-0 |
| 100 | 187 ±1,4 | 134 | +2,5/-0 |

Cushioning diagram



V = velocity [m/s]
m = mass

Overview drawing



NOTE: This overview drawing is only for orientation to indicate where the various accessory parts can be fastened to the cylinder. The illustration has been simplified for this purpose. It is thus not possible to derive the dimensions from this overview.