

# 5/3-directional valve, Series 502

R502A2B70MA00F1

General series information  
AVENTICS Series 502 Directional Control  
Valves

- The AVENTICS Series 502 is a line of general purpose automation valves designed for directional control and piloting applications requiring higher flow rates; less power consumption; and exceptionally easy on-site installation, configuration, and modification. The compact (18 mm), modular 502 Series is ideally suited for automotive and tire, food and beverage, pharmaceutical, and packaging machinery applications. The valve has the flexibility of meeting the ISO 15407-2 standard while maintaining its high-flow characteristics. In addition, no other valve in its class offers such a broad range of pressure regulator, pressure shut-off, and exhaust accessories.

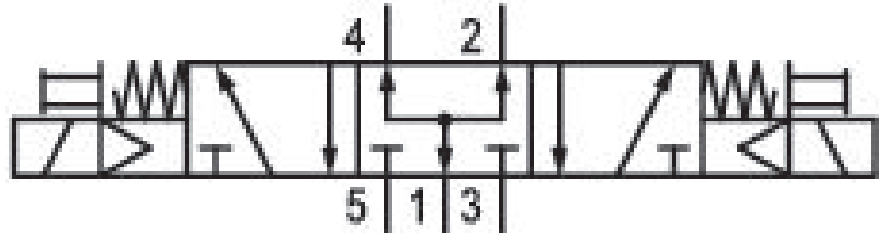

## Technical data

Industry	Industrial
Activation	Electrically
Valve type	Spool valve, positive overlapping
Valve function	Pressurized Center
Sealing principle	soft seal
Connection type	Plate connection
Manual override	without detent
Pilot control exhaust	with directional pilot air exhaust
Nominal flow Qn	490 l/min

Working pressure min.	-0.95 bar
Working pressure max	8 bar
Control pressure min.	3 bar
Control pressure max.	8 bar
Protection class with connection	IP65
Protective circuit	TVS diode
Reverse polarity protection	Protected against polarity reversal
Operational voltage	24 V DC
Voltage tolerance DC	-15% / +10%
Pilot	External
LED status display	Yellow
Power consumption DC	1.1 W
Typ. switch-on time	21 ms
Typ. switch-off time	27 ms
Blocking principle	Single base plate principle, can be assembled into blocks
Can be assembled into blocks	Can be assembled into blocks
Min. ambient temperature	-10 °C
Max. ambient temperature	50 °C
Min. medium temperature	-10 °C
Max. medium temperature	50 °C
Medium	Compressed air
Oil content of compressed air min.	0 mg/m <sup>3</sup>
Oil content of compressed air max.	5 mg/m <sup>3</sup>
Max. particle size	50 µm
mounting screws	with hexagon socket
Mounting screw tightening torque	2 Nm
Weight	0.167 kg

## Material

Housing material	Die cast zinc
Seal material	Nitrile butadiene rubber Polyurethane

Material front plate	Polyamide
Material end plate	Polyamide
Part No.	R502A2B70MA00F1

### Technical information

At operating voltage 24 V DC, power consumption for coil (cold) = 1.3 W , coil (hot) = 1.1 W

The min. control pressure must be adhered to, since otherwise faulty switching and valve failure may result!

The pressure dew point must be at least 15 °C less than ambient and medium temperature and may not exceed 3 °C.

The oil content of compressed air must remain constant during the life cycle.

### Dimensions

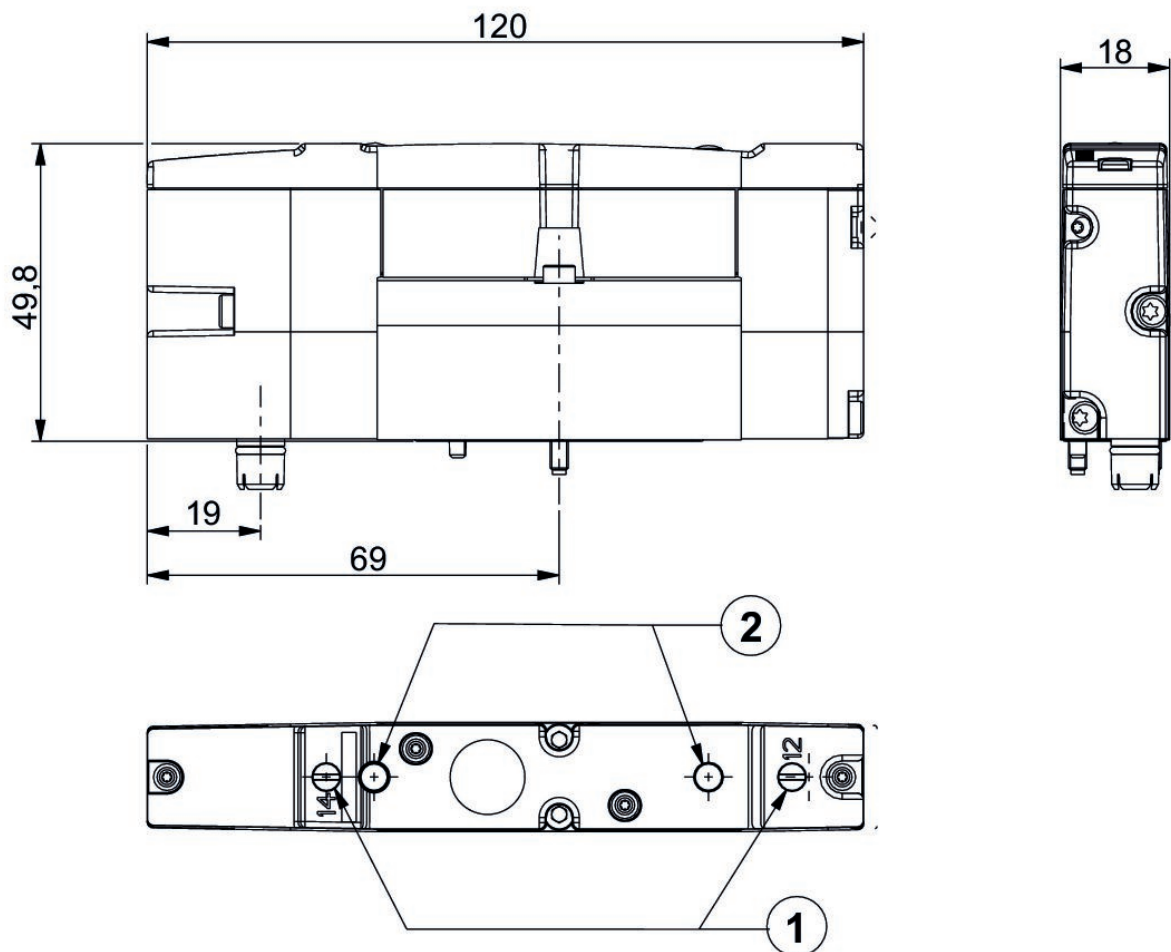

1) Manual override  
2) LED