

# Standard oil-mist lubricator, Series 652

G652AL0P40A0000

General series information  
Series 652

- The AVENTICS Series 652 is an easy-to-install line of pneumatic filters, regulators and lubricators (FRLs) that offer the industry's highest flow rates and widest temperature ratings. Available in 1/4-inch, 3/8-inch, and 1/2-inch port sizes, these FRLs are ideal for automotive and tire, packaging, food and beverage, and process applications requiring highly reliable operation and robust, modern-looking equipment. Available with integrated redundant safe exhaust valve and IIoT enabled air flow sensor.

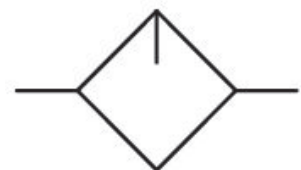

## Technical data

Industry	Industrial
Parts	Lubricator
Reservoir	Reservoir polycarbonate
Compressed air connection	G 1/2
Nominal flow Qn	6500 l/min
Working pressure min.	0 bar
Working pressure max	10 bar
Min. ambient temperature	5 °C
Max. ambient temperature	50 °C
Medium	Compressed air Neutral gases
Certificates	ATEX optional
ATEX	ATEX optional
Lubricator reservoir volume	72 cm <sup>3</sup>

Function	Oil-mist lubricator
Function	Can be assembled into blocks
Weight	0.53 kg

## Material

Housing material	Aluminum
Material front plate	Polycarbonate
Seal material	Nitrile butadiene rubber
Material reservoir	Polycarbonate
Part No.	G652AL0P40A0000

## Technical information

Recommended oil type  
Non-detergent type and without aggressive additives (VG32-ISO3448)

## Dimensions

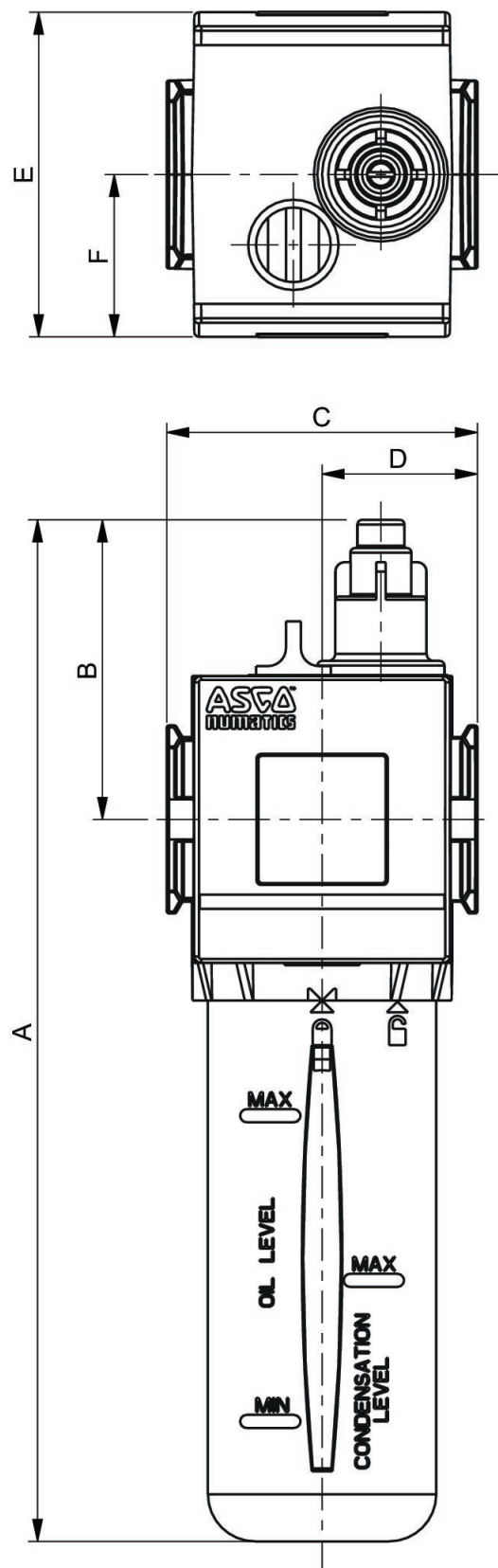

To remove the reservoir, allow a clearance of [[25] mm] from the bottom of the reservoir drain.

Series	652
A	217
B	64
C	66
D	33
E	69
F	30,5

## Accessories overview

