

AVENTICS Series AF2 Sensors

The AVENTICS Series AF2 are flow sensors that monitor air consumption in pneumatic systems, enabling rapid intervention in the event of leakage. The Series AF2 helps to optimize energy consumption, prevent machine downtime and cut costs.

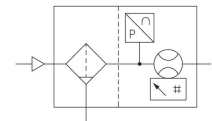

Technical data

Industry

Industrial

Note

Integrated web server, 48 VDC connection via Power over Ethernet
Without mounting

Frame size

AS5

Switching principle

Flow measuring principle: calorimetric

Protocol

Ethernet
TCP/IP
OPC UA
MQTT

Nominal flow

4326 l/min

Nominal flow Q_n min., standard

22 l/min

Nominal flow Q_n max., standard

4326 l/min

Nominal flow Q_n min., extended

4326 l/min

Nominal flow Q_n max., extended

6490 l/min

Compressed air connection

G 1

Certificates

CE declaration of conformity
RoHS
UL (Underwriters Laboratories)

Min. working pressure

0 bar

Max. working pressure

16 bar

AF2 series flow rate sensor, Ethernet

AF2

R412027181

2024-03-04

Min. ambient temperature	-20 °C
Max. ambient temperature	60 °C
Min. medium temperature	-20 °C
Max. medium temperature	60 °C
Medium	Compressed air Argon Nitrogen Carbon dioxide
Filter porosity	5 µm
Display	OLED
Flow display unit	l/sec l/min m ³ /min m ³ /h ft ³ /s m ³ /min
Pressure display unit	bar psi
Temperature display unit	°C °F
Electrical connection 2, type	Plug
Electrical connection 2, thread size	M12x1
Electrical connection 2, number of poles	8-pin
Output signal	OPC UA, MQTT, Integrated web server
Max. power consumption	5 W
Operational voltage	24 V DC
Min. operating voltage DC	36 V DC
Max. operating voltage DC	57 V DC
Response time	< 10 ms
Max. shock resistance	30 g, 11 ms
Vibration resistance	1 g (10 - 2000 Hz) IEC 60068 - 2-6
Reproducibility	± 1.5% of the measured value
Protection class	IP65 IP67 according to IEC 60529
Weight	2.3 kg

Material

Housing material	Polyamide Polycarbonate
Seal material	Fluorocautchouc
Part No.	R412027181

Technical information

The pressure dew point must be at least 15 °C less than ambient and medium temperature and may not exceed 3 °C.

The protection class is only ensured when the plug is mounted properly. For detailed information, see operating instructions.

The device is designed to be installed in AS series air preparation units or to be fitted as a stand-alone device using a W05 block assembly kit.

Liquid oil or water must be separated via prefiltering. If it is not separated sufficiently, drifting may result.

Precision

- Standard measurement range: $\pm 3\%$ of measured value, + 0.3% of final value
- Extended measurement range: $\pm 8\%$ of measured value, + 1% of final value

Operating voltage via PoE (in accordance with IEEE 802.3af)

The pressure dew point must be at least 15 °C less than ambient and medium temperature and may not exceed 3 °C.

The oil content of compressed air must remain constant during the life cycle.

Use only the approved oils from AVENTICS. Further information can be found in the "Technical information" document (available in <https://www.emerson.com/en-us/support>).

AF2 series flow rate sensor, Ethernet

R412027181

AF2

2024-03-04

Dimensions in mm

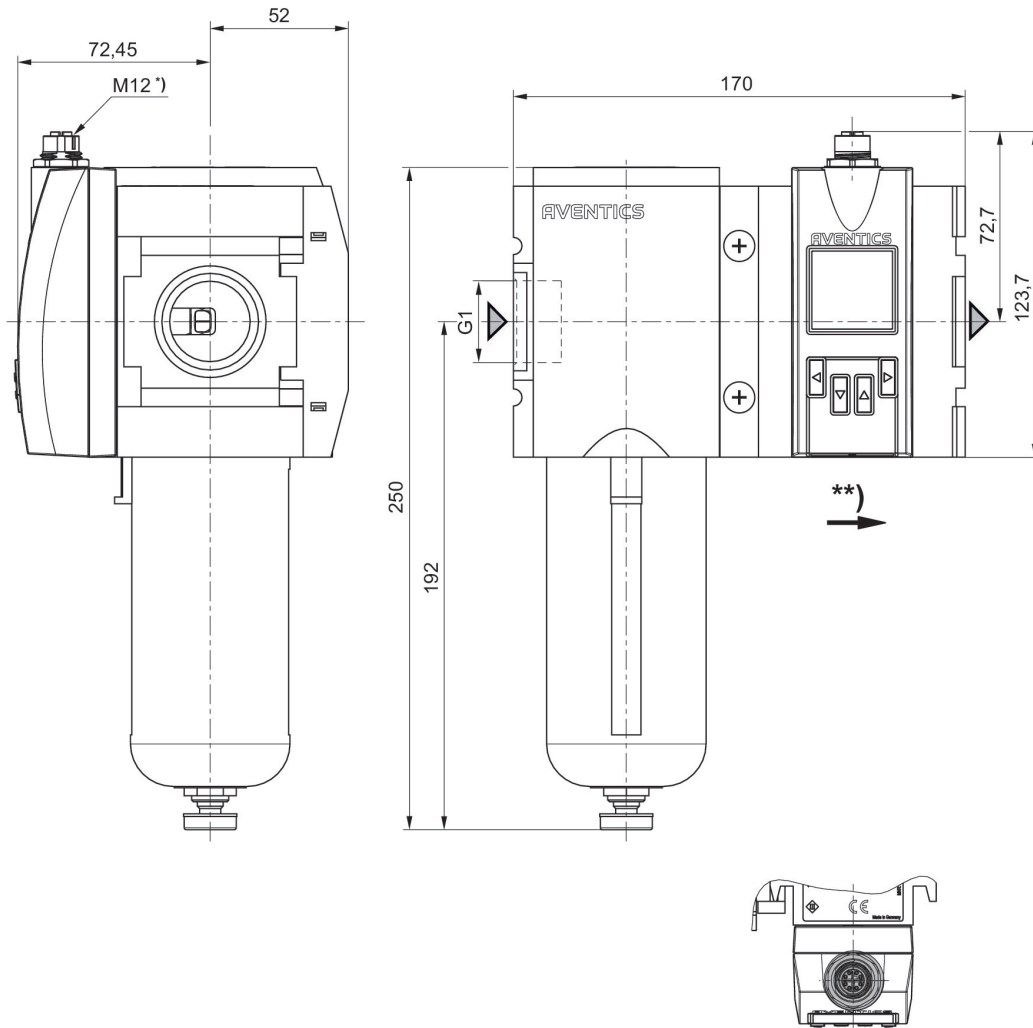

* Internal thread

** Flow direction

Pin assignments

M12

X-coded

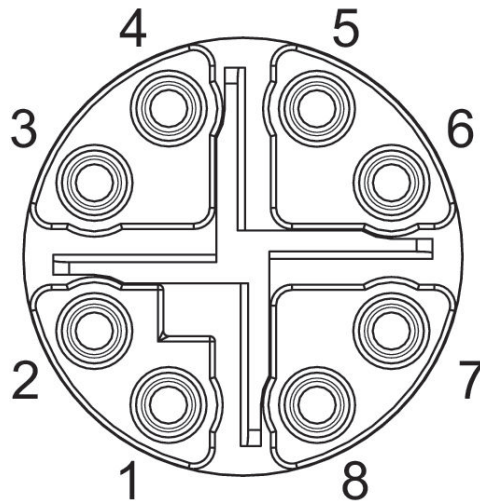

Pin assignments

Pin	RJ45	Wire color	Identification	10/100 Mbit
1	1	WH / OG	TX(+) + POE	TxData+
2	2	OG	TX(-) + POE	TxData+
3	3	WH / GN	RX(+) - POE	TxData-
4	6	GN	RX(-) - POE	TxData-
7	5	WH / BU	POE+	
8	4	BU	POE+	
5	7	WH / BN	POE-	
6	8	BN	POE-	