

Filter pressure regulator, Series AS1-FRE

R412014650

General series information
AVENTICS Series AS1 Air Preparation Units

- The AVENTICS Series AS1 is a modular, versatile maintenance unit for universal application. This Series offers compact dimensions, is highly efficient, lightweight and easy-to-use. The AVENTICS Series AS guarantees reliability, safety, and efficiency with a simplified assembly and maintenance efforts.

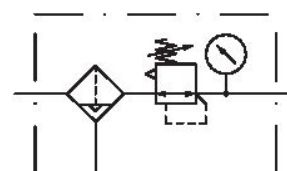

Technical data

| | |
|--------------------------|--|
| Industry | Industrial |
| Parts | Filter pressure regulator |
| Reservoir | Metal reservoir without window |
| Port | G 1/4 |
| Nominal flow Qn | 1000 l/min |
| Filter porosity | 5 µm |
| Condensate drain | fully automatic, open without pressure |
| Pressure gauge | With integrated pressure gauge |
| Working pressure min. | 1.5 bar |
| Working pressure max | 12 bar |
| Min. ambient temperature | -10 °C |
| Max. ambient temperature | 50 °C |
| Air supply | left |
| Regulation range min. | 0.5 bar |
| Regulation range max. | 8 bar |
| Lock type | not lockable |
| Type | 1-part |
| Type | Can be assembled into blocks |
| Pressure supply | single |

| | |
|--|-----------------------------------|
| Mounting orientation | vertical |
| Regulator type | Diaphragm-type pressure regulator |
| Regulator function | with relieving air exhaust |
| Filter element | exchangeable |
| Filter reservoir volume | 16 cm ³ |
| Max. achievable compressed air class acc. to ISO 8573-1:2010 | 6 : 7 : - |
| Medium | Compressed air Neutral gases |
| Weight | 0.33 kg |

Material

| | |
|------------------------|---------------------------------|
| Housing material | Polyamide |
| Seal material | Acrylonitrile butadiene rubber |
| Material front plate | Acrylonitrile butadiene styrene |
| Material reservoir | Die cast zinc |
| Material filter insert | Cellpor |
| Part No. | R412014650 |

Technical information

The pressure dew point must be at least 15 °C less than ambient and medium temperature and may not exceed 3 °C.

Also suitable for separation of fluid oil or water due to the design.

Nominal flow Q_n with secondary pressure p₂ = 6 bar at Δp = 1 bar

Dimensions in mm

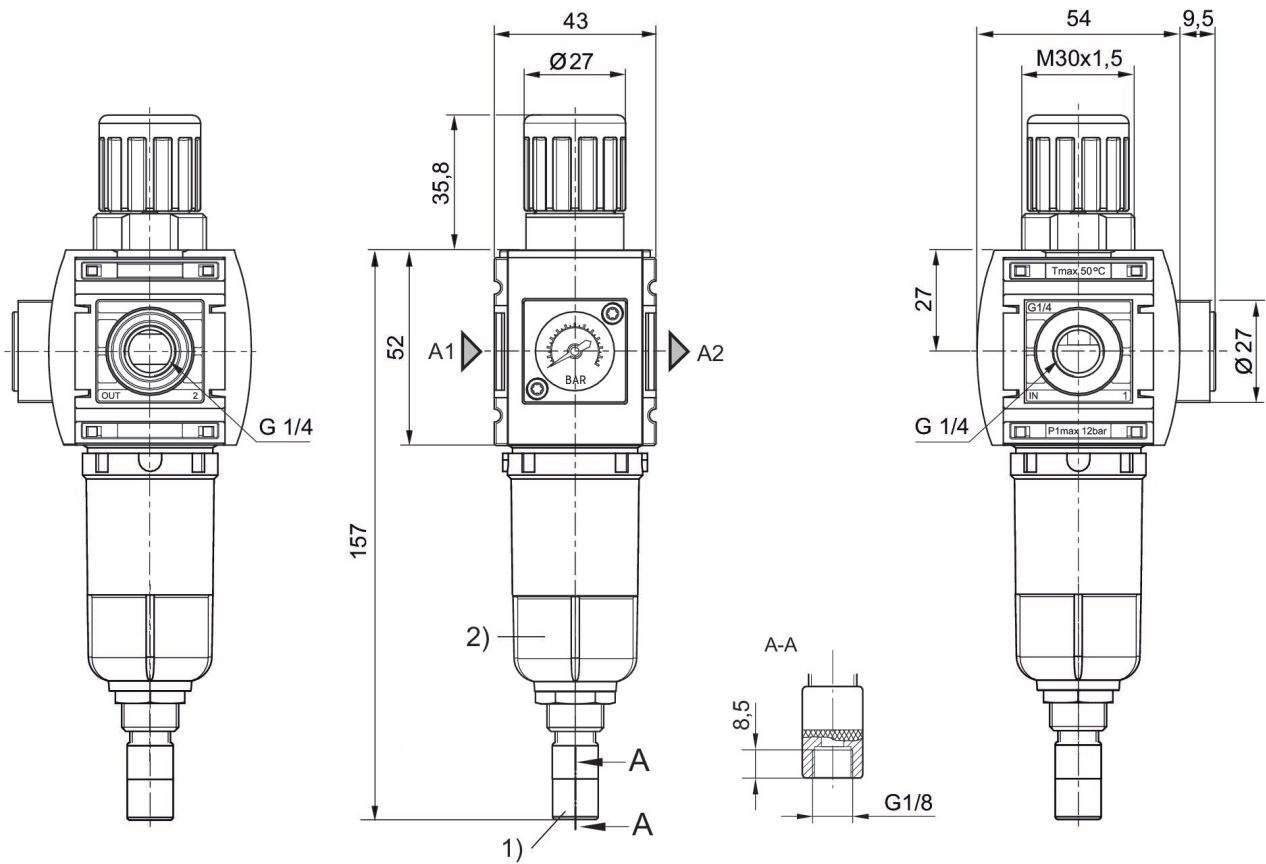

- 1) Fully automatic condensate drain
2) Reservoir: metal

Flow rate characteristic, $p_2 = 0,05 - 7$ bar

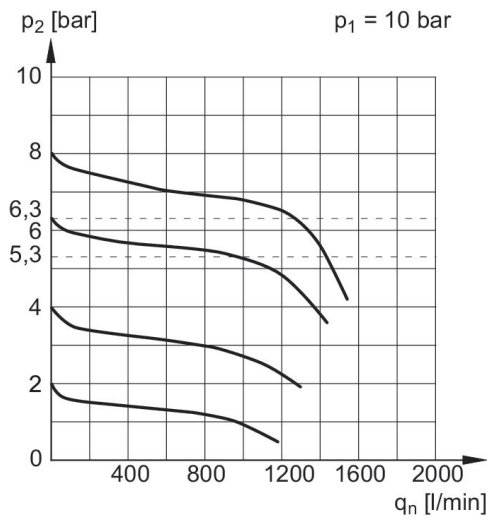

p_1 = Working pressure
 p_2 = Secondary pressure
 q_n = Nominal flow

Pressure characteristics curve

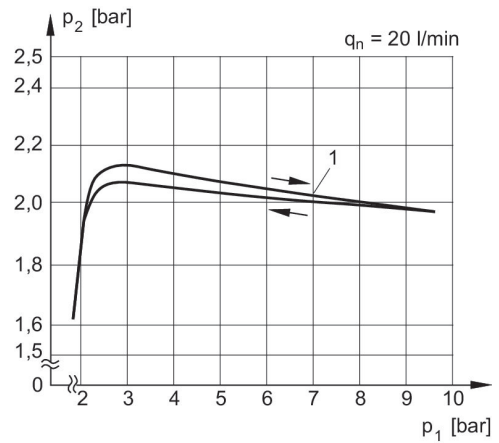

p_1 = Working pressure
 p_2 = Secondary pressure
 q_n = Nominal flow
1) = Starting point

Accessories overview

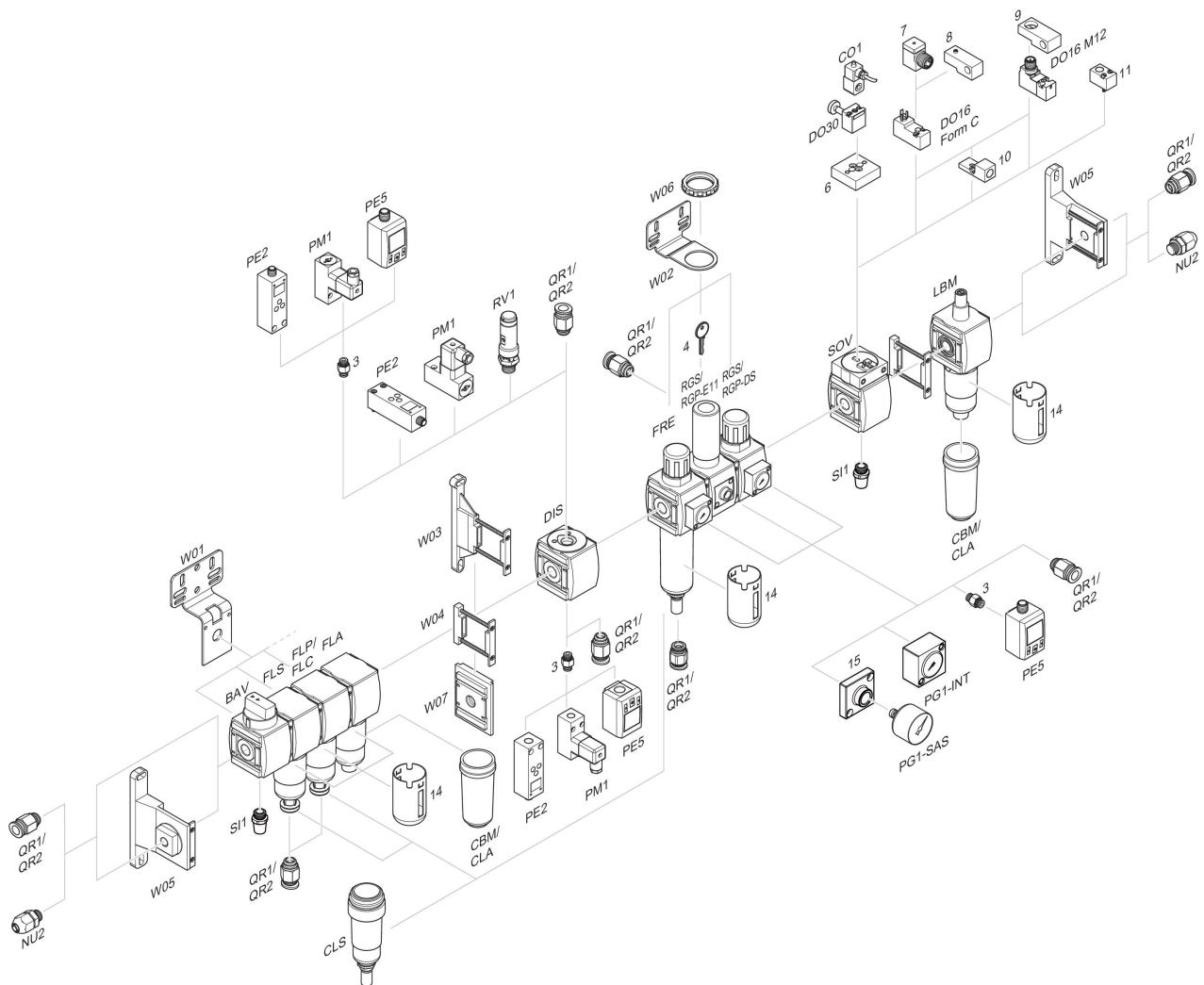

3 = Double nipple 4 = Key for E11 locking 6 = Transition plate DO30 7 = Adapter, Series CON-VP 8 = Mounting aid DO16, form C 9 = Mounting aid DO16, M12 10 = Adapter for external pilot air 11 = Adapter pneumatic operation 14 = Protective guard 15 = Transition plate for assembling a pressure gauge with connection thread G 1/8