

Filling valve, pneumatically operated, Series AS2-SSV

R412006311

General series information Series AS2

- The AVENTICS Series AS2 is a modular, versatile maintenance unit for universal application. This Series offers compact dimensions, is highly efficient, lightweight and easy-to-use. The AVENTICS Series AS guarantees reliability, safety, and efficiency with a simplified assembly and maintenance efforts.

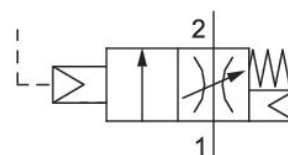

Technical data

Industry
Industrial

Type
With pneumatic priority circuit, adjustable filling time.

Activation
Pneumatically

Parts
Filling valve

Nominal flow Qn
1900 l/min

Compressed air connection
G 1/4

Working pressure min.
1 bar

Working pressure max
16 bar

Connection type
Pipe connection

Sealing principle
Soft Seal

Type
Poppet valve
Can be assembled into blocks
Can be assembled into blocks

Min. ambient temperature
0 °C

Max. ambient temperature
50 °C

Medium
Compressed air
Neutral gases

Max. particle size
40 µm

Compressed air connection pilot exhaust
G 1/8

Nominal flow Qn 1 to 2
1900 l/min

Weight
0.314 kg

Material

Housing material

Polyamide

Seal material

Acrylonitrile butadiene rubber

Material, front cover

Acrylonitrile butadiene styrene

Material threaded bushing

Die cast zinc

Part No.

R412006311

Technical information

The pressure dew point must be at least 15 °C under ambient and medium temperature and may not exceed 3 °C .

Nominal flow Q_n with secondary pressure $p_2 = 6,3$ bar at $\Delta p = 1$ bar

A change in the flow direction (from air supply on the left to air supply on the right) occurs by rotating installation by 180° about the vertical axis. Please see the operating instructions for further details.

The filling valve builds up pressure slowly in the pneumatic systems, i.e. prevents a sudden pressure build-up during a recommissioning after a mains pressure failure or avoids emergency OFF switching. This allows dangerous abrupt cylinder motions to be avoided.

Actuating the electric priority circuit disrupts the slow pressure build-up and pressure p_1 is immediately applied.

For unthrottled operation, the filling valve must be permanently electrically actuated.

Dimensions in mm

Fig. 1

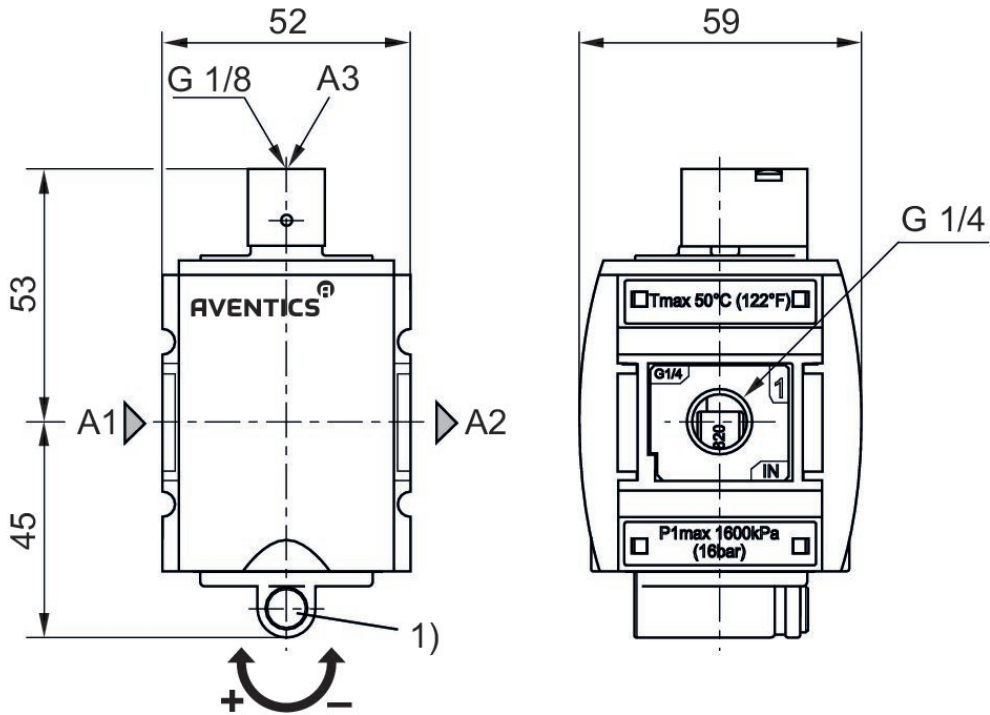

A1 = input A2 = output
A3 = control pressure connection
1) Adjustment screw for filling time

Dimensions in mm

Fig. 2

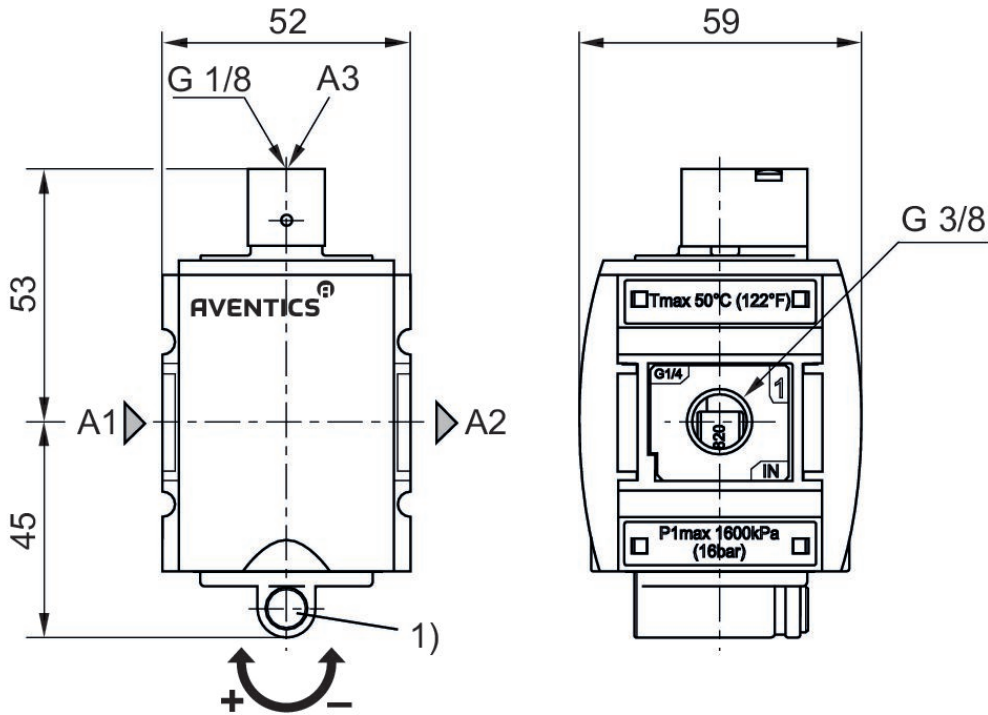

A1 = input A2 = output
A3 = control pressure connection
1) Adjusting screw for filling time

Secondary pressure while filling

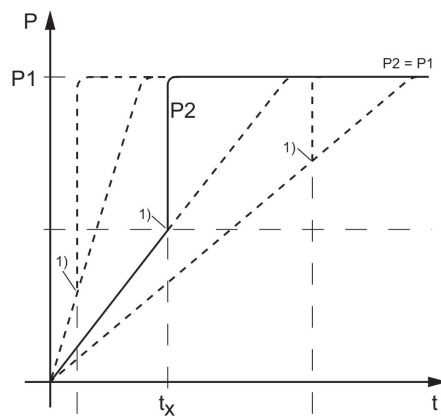

p1 = Working pressure
p2 = output pressure
t = filling time
tx = switchover time
1) Pneumatically triggered switching point
Filling time adjustable via adjustment screw (throttle)

control pressure characteristic

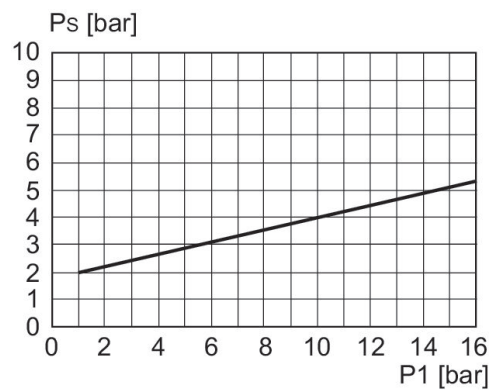

p1 = Working pressure
PS = control pressure

Flow rate characteristic, $p_2 = 0,05 - 7$ bar

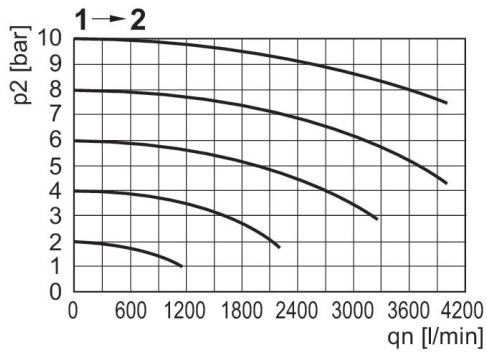

p_2 = secondary pressure q_n = nominal flow

Accessories overview

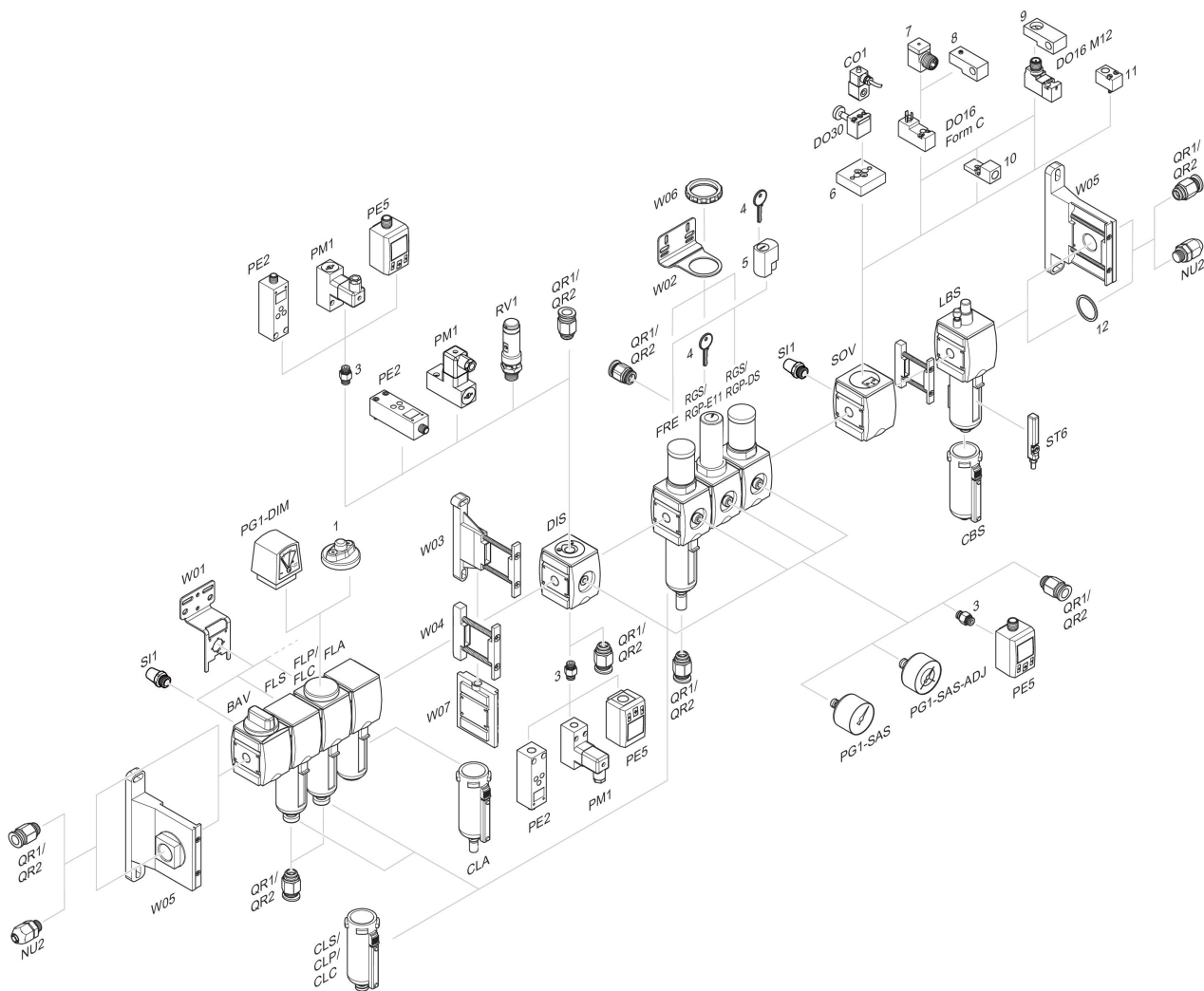

1 = contamination display 3 = Double nipple 4 = Key for E11 locking 5 = mortise lock 6 = Transition plate DO30 7 = Adapter, Series CON-VP 8 = Mounting aid DO16, form C 9 = Mounting aid DO16, M12 10 = Adapter for external pilot air 11 = Adapter pneumatic operation 12 = Sealing ring