

AVENTICS Series AS3 Air Preparation Units

The AVENTICS Series AS3 is a modular, versatile maintenance unit for universal application. This Series offers compact dimensions, is highly efficient, lightweight and easy-to-use. The AVENTICS Series AS guarantees reliability, safety, and efficiency with a simplified assembly and maintenance efforts.

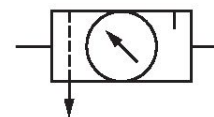

Technical data

Industry	Industrial
Parts	Air preparation units
Components	Filter pressure regulator Lubricator
Reservoir	reservoir, metal, with inspection glass
Port	G 1/2
Nominal flow Qn	3500 l/min
Filter porosity	5 µm
Condensate drain	semi-automatic, open without pressure
Pressure gauge	with pressure gauge
Min. working pressure	1.5 bar
Max. working pressure	16 bar
Min. ambient temperature	-10 °C
Max. ambient temperature	50 °C
Min. regulation range	0.5 bar
Max. regulation range	8 bar
Lock type	for padlocks
Type	2-part
Type	Can be assembled into blocks
Pressure supply	single

Mounting orientation	vertical
Regulator type	Diaphragm-type pressure regulator
Regulator function	with relieving air exhaust
Filter element	exchangeable
Filter reservoir volume	49 cm ³
Max. achievable compressed air class acc. to ISO 8573-1:2010	6 : 7 : -
Lubricator reservoir volume	80 cm ³
Type of filling	Semi-automatic oil filling during operation Manual oil filling
Medium	Compressed air Neutral gases
Weight	1.83 kg

Material

Housing material	Polyamide
Seal material	Acrylonitrile butadiene rubber
Material front plate	Acrylonitrile butadiene styrene
Material threaded bushing	Die cast zinc
Material reservoir	Die cast zinc
Material protective guard	Polyamide
Material filter insert	Polyethylene
Part No.	R412007313

Technical information

The pressure dew point must be at least 15 °C less than ambient and medium temperature and may not exceed 3 °C.

A change in the flow direction (from air supply on the left to air supply on the right) occurs by rotating installation by 180° about the vertical axis. Please see the operating instructions for further details.

Also suitable for separation of fluid oil or water due to the design.

Nominal flow Q_n with secondary pressure p₂ = 6 bar at Δp = 1 bar

Dimensions in mm

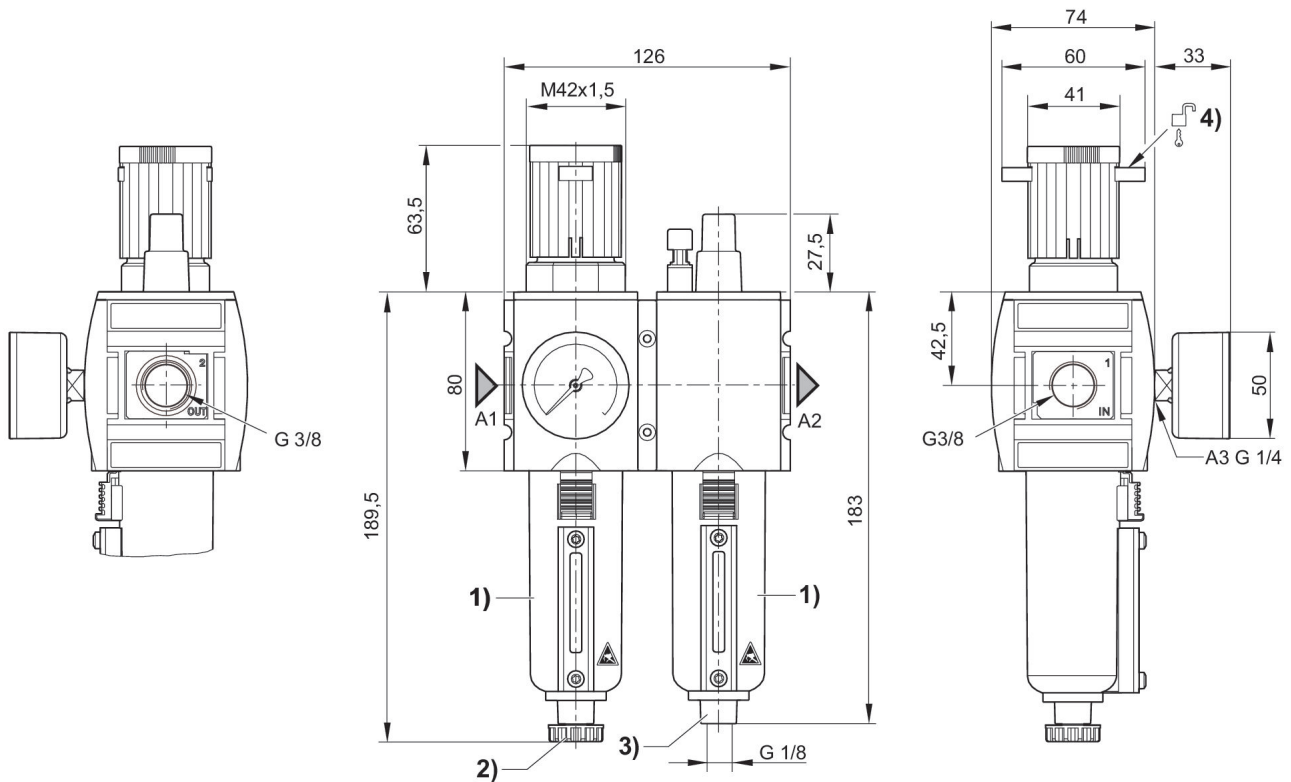

- A1 = input
- A2 = output
- A3 = pressure gauge connection
- 1) Metal reservoir with level indicator
- 2) Semi-automatic condensate drain
- 3) Port for semi-automatic oil filling
- 4) Mounting option for padlocks, max. shackle Ø 8

Flow rate characteristic (p₂: 0,5 - 8 bar)

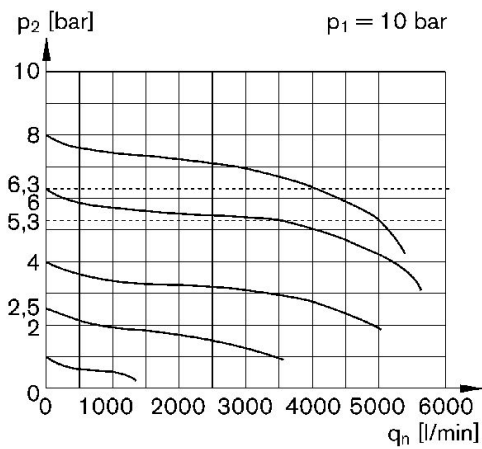

p_1 = Working pressure
 p_2 = Secondary pressure
 q_n = Nominal flow

Lubricator activation margin

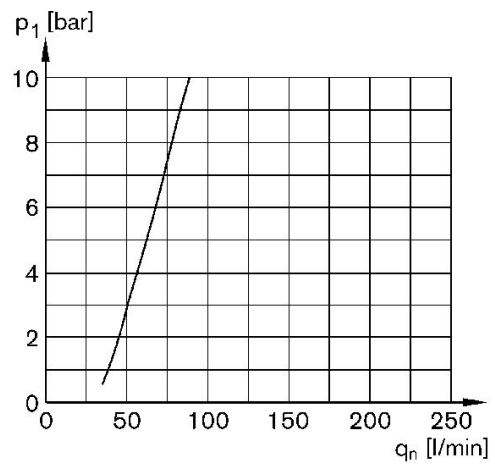

p_1 = Working pressure
 q_n = Nominal flow

Accessories overview

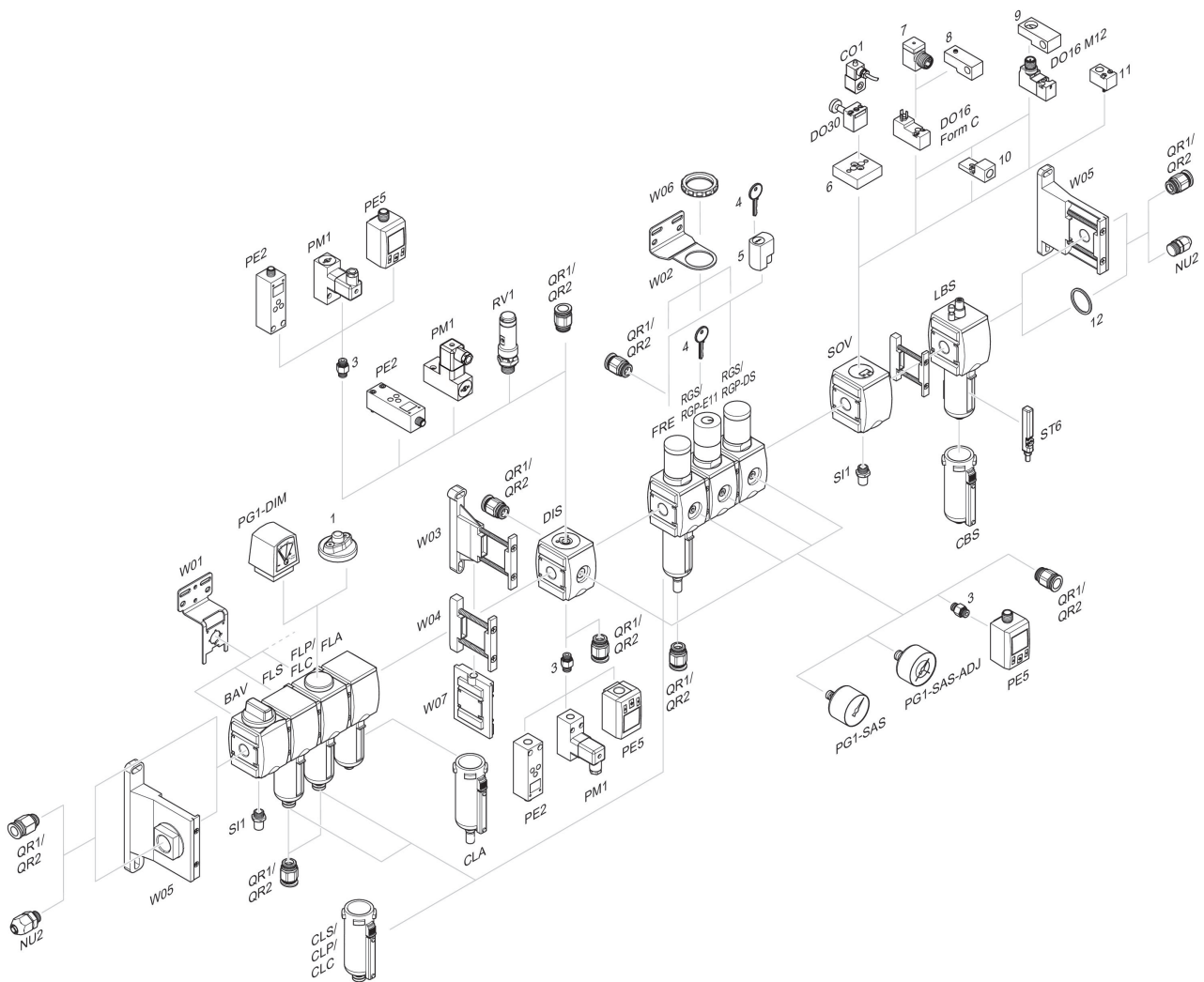

1 = contamination display 3 = Double nipple 4 = Key for E11 locking 5 = mortise lock 6 = Transition plate DO30 7 = Adapter, Series CON-VP 8 = Mounting aid DO16, form C 9 = Mounting aid DO16, M12 10 = Adapter for external pilot air 11 = Adapter pneumatic operation 12 = Sealing ring