

# Filling unit, electrically operated, Series AS3-SSU

R412007280

Series AS3

2024-03-28

## Series AS3

The AVENTICS Series AS3 is a modular, versatile maintenance unit for universal application. This Series offers compact dimensions, is highly efficient, lightweight and easy-to-use. The AVENTICS Series AS guarantees reliability, safety, and efficiency with a simplified assembly and maintenance efforts.

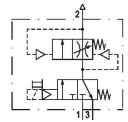

## Technical data

Industry	Industrial
Type	adjustable filling time
Activation	Electrically
Nominal flow Qn	3500 l/min
Compressed air connection	G 3/8
Min. working pressure	2.5 bar
Max. working pressure	10 bar
Operational voltage AC at 50 Hz	220 V
Operational voltage AC at 60 Hz	230 V
Sealing principle	Soft seal
Pilot	Internal
Connection type	Pipe connection
Parts	3/2-directional valve Filling valve
Can be assembled into blocks	Can be assembled into blocks
Basic valve equipment	Basic valve with pilot valve
Type	Poppet valve
Min. ambient temperature	-10 °C
Max. ambient temperature	50 °C
Medium	Compressed air

# Filling unit, electrically operated, Series AS3-SSU

Series AS3

2024-03-28

R412007280

	Neutral gases
Max. particle size	25 µm
Compressed air connection, exhaust	G 1/2
Nominal flow Qn 1 to 2	3500 l/min
Nominal flow Qn 2 to 3	3200 l/min
Operating voltage	220-230 V AC
Holding power AC 50 Hz	1.6 VA
Holding power AC 60 Hz	1.4 VA
Switch-on power AC 50 Hz	2.2 VA
Switch-on power AC 60 Hz	1.6 VA
Duty cycle	100 %
Connector standard	ISO 15217
Protection class with connection	IP65
Reverse polarity protection	Protected against polarity reversal
Electrical connection 1, type	Plug
Electrical connection 1, thread size	ISO 15217, form C
Weight	0.924 kg

## Material

Housing material	Polyamide
Seal material	Acrylonitrile butadiene rubber
Material threaded bushing	Die cast zinc
Material front plate	Acrylonitrile butadiene styrene
Part No.	R412007280

## Technical information

The pressure dew point must be at least 15 °C less than ambient and medium temperature and may not exceed 3 °C.

Nominal flow Qn with secondary pressure  $p_2 = 6$  bar at  $\Delta p = 0,1$  bar

A change in the flow direction (from air supply on the left to air supply on the right) occurs by rotating installation by 180° about the vertical axis. Please see the operating instructions for further details.

Do not position filling valves or filling units upstream of open consumers, such as nozzles, air barriers, air curtains, since these may prevent through connection of components.

The filling valve builds up pressure slowly in the pneumatic systems, i.e. prevents a sudden pressure build-up during a recommissioning after a mains pressure failure or avoids emergency OFF switching. This allows dangerous abrupt cylinder motions to be avoided.

The delivered product may vary from that in the illustration.

# Filling unit, electrically operated, Series AS3-SSU

Series AS3

2024-03-28

R412007280  
Dimensions in mm

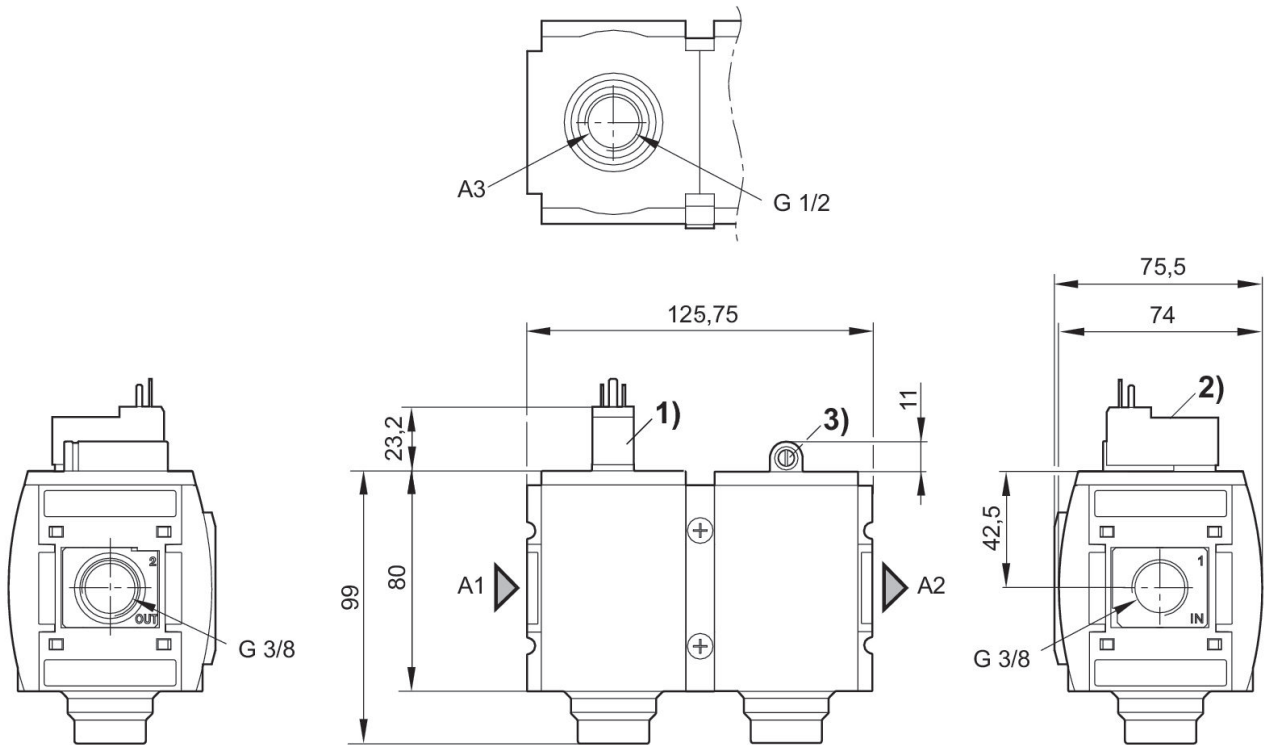

- A1 = input
- A2 = output
- A3 = ventilation port
- 1) Connection for valve plug connector according to ISO 15217 (form C)
- 2) Manual override
- 3) Adjustment screw for filling time

## Flow rate characteristic, $p_2 = 0,05 - 7$ bar Secondary pressure while filling

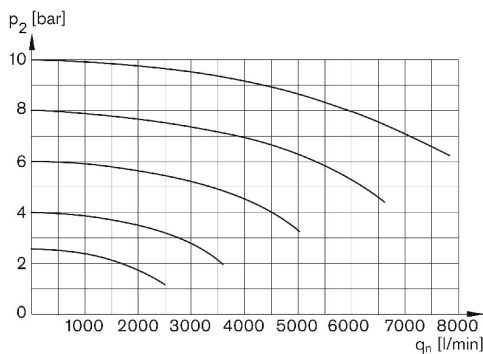

$p_2$  = Secondary pressure  
 $q_n$  = Nominal flow

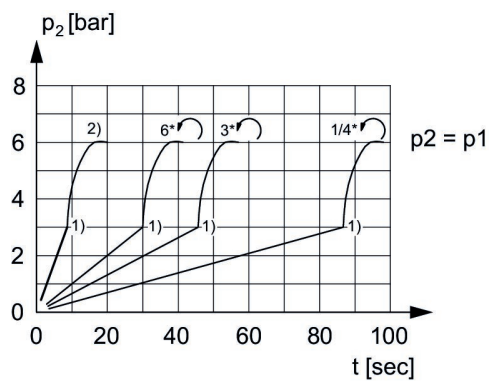

$p_1$  = Working pressure  
 $p_2$  = Secondary pressure  
 $t$  = filling time, adjustable via adjustment screw (throttle)  
1) Switching point: adjustable filling time, fixed change-over pressure  $\approx 0.5 \times p_1$  (50%)  
2) Throttle fully opened  
\* Adjustment screw rotations

# Filling unit, electrically operated, Series AS3-SSU

Series AS3

2024-03-28

R412007280  
Pin assignment M12x1

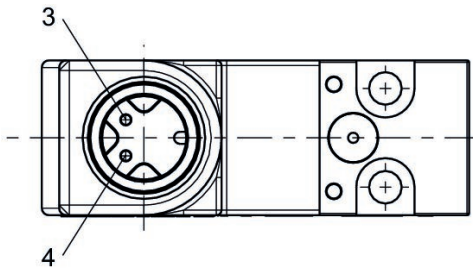

3: +/-  
4: +/-

## Accessories overview

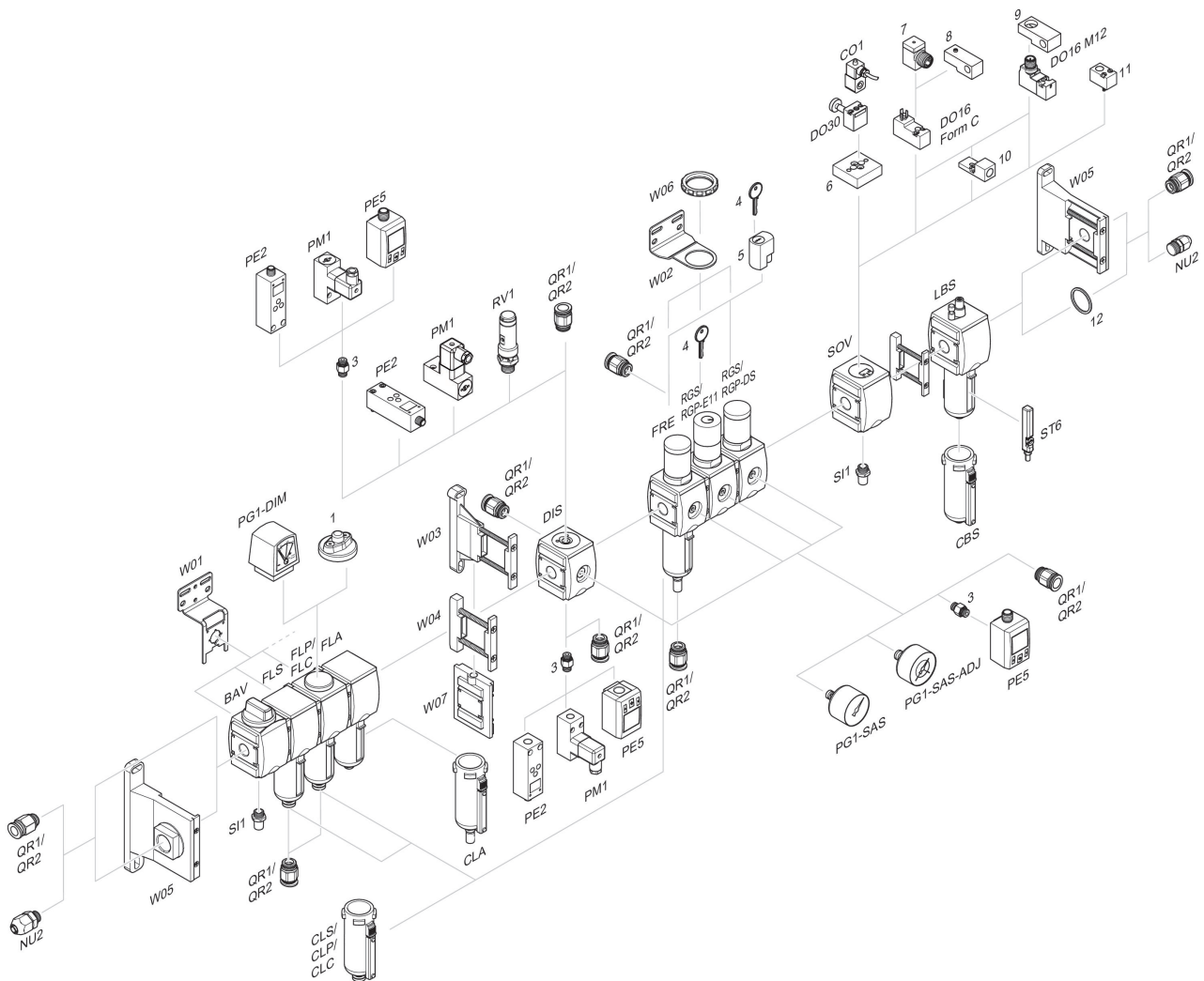

1 = contamination display 3 = Double nipple 4 = Key for E11 locking 5 = mortise lock 6 = Transition plate DO30 7 = Adapter, Series CON-VP 8 = Mounting aid DO16, form C 9 = Mounting aid DO16, M12 10 = Adapter for external pilot air 11 = Adapter pneumatic operation 12 = Sealing ring