

Microfilter, Series AS5-FLC

2024-03-20

R412009036

Series AS5

The AVENTICS Series AS5 is a modular, versatile maintenance unit for universal application. This Series offers compact dimensions, is highly efficient, lightweight and easy-to-use. The AVENTICS Series AS guarantees reliability, safety, and efficiency with a simplified assembly and maintenance efforts.

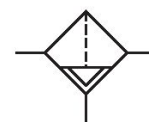

Technical data

Industry	Industrial
Parts	Microfilter
Reservoir	reservoir, polycarbonate, with PA protective guard
Port	G 3/4
Filter porosity	0.01 μm
Nominal flow Qn	1600 l/min
Condensate drain	semi-automatic, open without pressure
Min. working pressure	1.5 bar
Max. working pressure	16 bar
Min. ambient temperature	-10 °C
Max. ambient temperature	50 °C
Medium	Compressed air Neutral gases
Max. achievable compressed air class acc. to ISO 8573-1:2010	1 : - : 2
Filter reservoir volume	87 cm ³
Filter element	exchangeable
Recommended pre-filtering	0.3 μm
Weight	0.71 kg

Microfilter, Series AS5-FLC

2024-03-20

R412009036

Mounting orientation	vertical
Type	Can be assembled into blocks

Material

Housing material	Polyamide
Material front plate	Acrylonitrile butadiene styrene
Seal material	Acrylonitrile butadiene rubber
Material threaded bushing	Die cast zinc
Material reservoir	Polycarbonate
Material protective guard	Polyamide
Material filter insert	Borosilicate glass fiber
Part No.	R412009036

Technical information

The pressure dew point must be at least 15 °C less than ambient and medium temperature and may not exceed 3 °C.

Note: Polycarbonate reservoirs are susceptible to solvents, supplementary information can be found at "Customer information".

A change in the flow direction (from air supply on the left to air supply on the right) occurs by rotating installation by 180° about the vertical axis. Please see the operating instructions for further details.

Microfilter, Series AS5-FLC

2024-03-20

R412009036

Dimensions

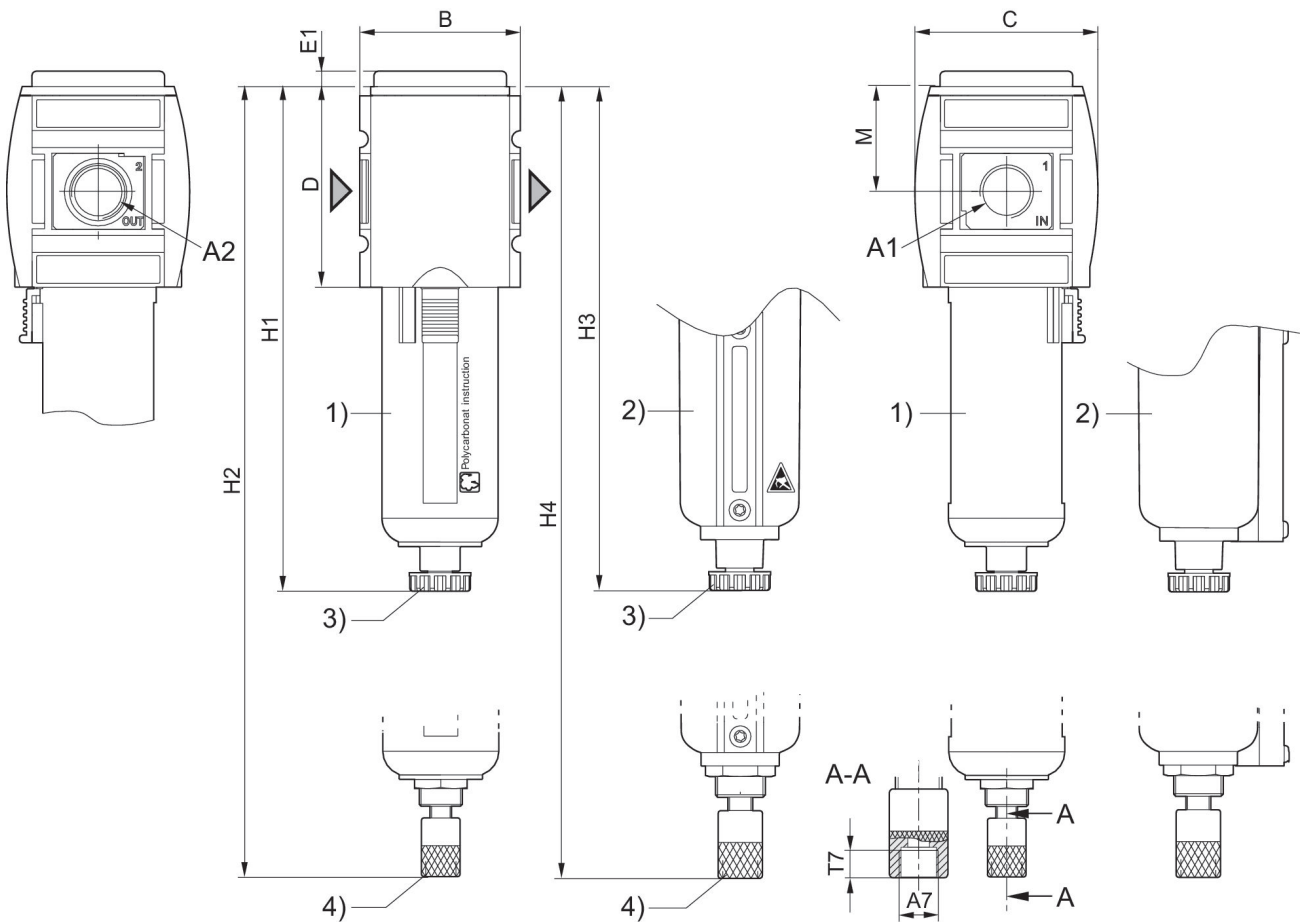

A1 = input A2 = output

A7 = condensate drain

1) Plastic reservoir and protective guard with window

2) Metal reservoir with inspection glass

3) Semi-automatic condensate drain

4) Fully automatic condensate drain

Dimensions in mm

Part No.	A1	A2	A7	B	C	D	E1	H1	H2
R412009036	G 3/4	G 3/4	G 1/8	85	103	109	5	250	266
R412009037	G 3/4	G 3/4	G 1/8	85	103	109	5	250	266
R412009038	G 3/4	G 3/4	G 1/8	85	103	109	5	250	266
R412009042	G 3/4	G 3/4	G 1/8	85	103	109	5	250	266
R412009043	G 3/4	G 3/4	G 1/8	85	103	109	5	250	266
R412009044	G 3/4	G 3/4	G 1/8	85	103	109	5	250	266
R412009045	G 1	G 1	G 1/8	85	103	109	5	250	266
R412009046	G 1	G 1	G 1/8	85	103	109	5	250	266
R412009047	G 1	G 1	G 1/8	85	103	109	5	250	266
R412009051	G 1	G 1	G 1/8	85	103	109	5	250	266
R412009052	G 1	G 1	G 1/8	85	103	109	5	250	266
R412009053	G 1	G 1	G 1/8	85	103	109	5	250	266

Microfilter, Series AS5-FLC

2024-03-20

R412009036

Part No.	H3	H4	M	T7
R412009036	254	270	58	8.5
R412009037	254	270	58	8.5
R412009038	254	270	58	8.5
R412009042	254	270	58	8.5
R412009043	254	270	58	8.5
R412009044	254	270	58	8.5
R412009045	254	270	58	8.5
R412009046	254	270	58	8.5
R412009047	254	270	58	8.5
R412009051	254	270	58	8.5
R412009052	254	270	58	8.5
R412009053	254	270	58	8.5

Flow rate characteristic, $p_2 = 0,05 - 7$ bar

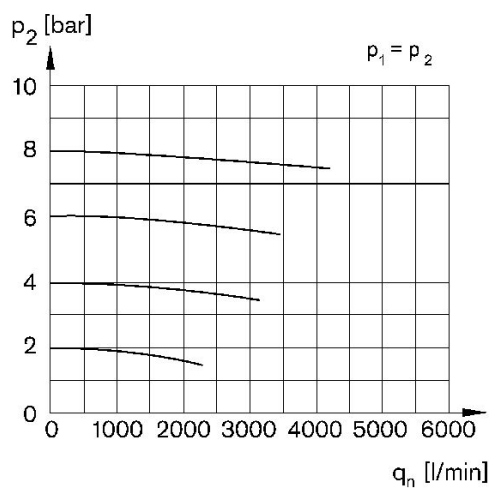

p_1 = Working pressure p_2 = Secondary pressure q_n = Nominal flow

Accessories overview

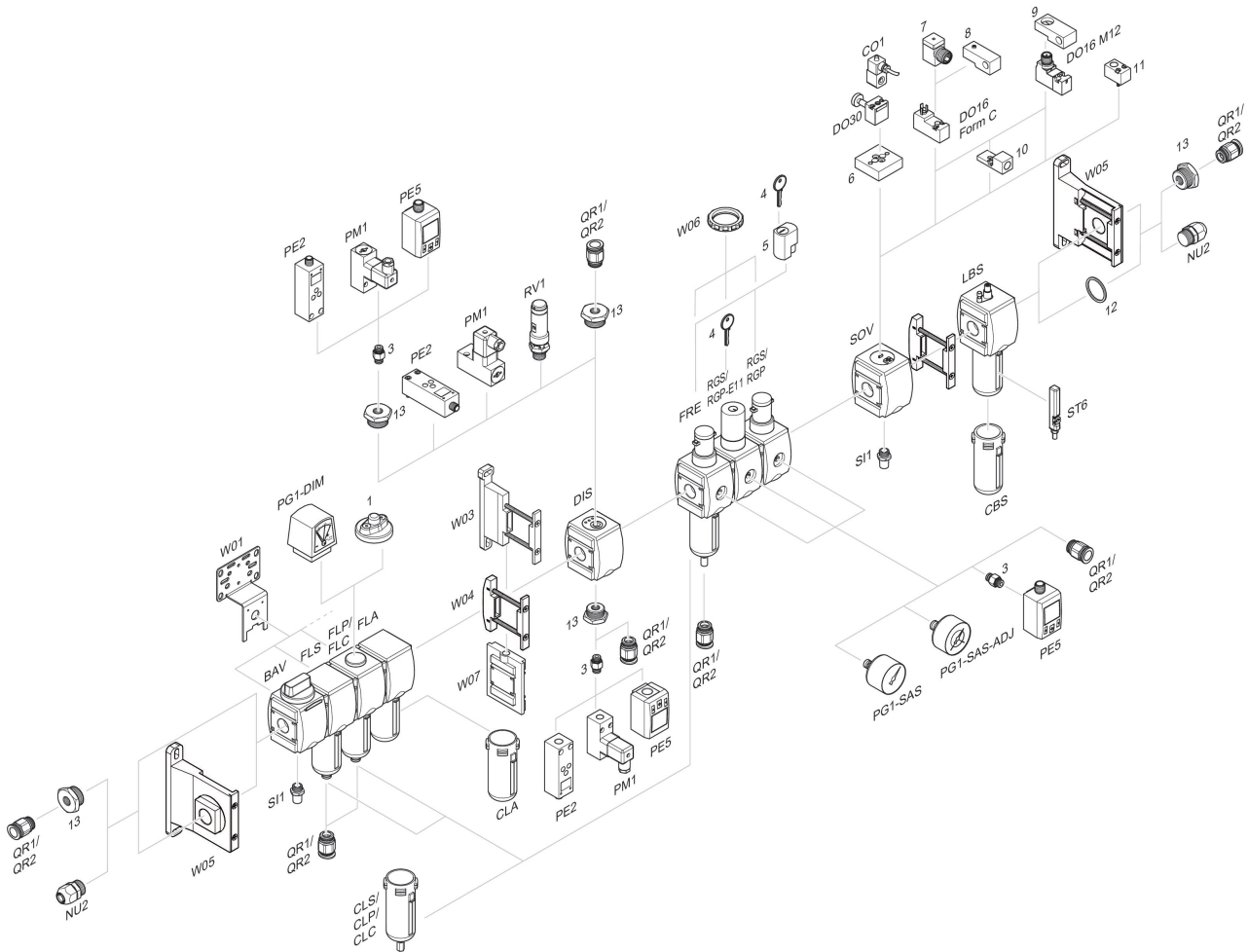

1 = contamination display 3 = Double nipple 4 = Key for E11 locking 5 = mortise lock 6 = Transition plate DO30 7 = Adapter, Series CON-VP 8 = Mounting aid DO16, form C 9 = Mounting aid DO16, M12 10 = Adapter for external pilot air 11 = Adapter pneumatic operation 12 = Sealing ring 13 = Reducing nipple