

# 3/2-directional valve, electrically operated, Series AS5-SOV-...-POS

R412009388

## General series information Series AS5

- The AVENTICS Series AS5 is a modular, versatile maintenance unit for universal application. This Series offers compact dimensions, is highly efficient, lightweight and easy-to-use. The AVENTICS Series AS guarantees reliability, safety, and efficiency with a simplified assembly and maintenance efforts.

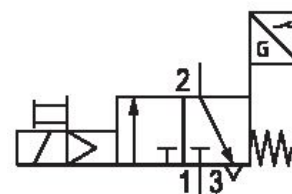

## Technical data

Industry	Industrial
Type	With position inquiry, with integrated sensor
Activation	Electrically
Nominal flow Qn	12500 l/min
Compressed air connection	G 1
Working pressure min.	2.5 bar
Working pressure max	10 bar
DC operating voltage	24 V
Sealing principle	soft seal
Parts	3/2-directional valve
Can be assembled into blocks	Can be assembled into blocks
basic valve with electrical connector	Basic valve with pilot valve
Type	Poppet valve

Min. ambient temperature	-10 °C
Max. ambient temperature	50 °C
Medium	Compressed air Neutral gases
Max. particle size	25 µm
Compressed air connection, exhaust	G 1/2
Nominal flow Qn 1 to 2	12500 l/min
Nominal flow Qn 2 to 3	3700 l/min
Operating voltage	24 V DC
Power consumption DC	2 W
Protection class with connection	IP65
Electrical connection type 2	Plug
Electrical connection 2, thread size	ISO 15217, form C
Electrical connection for sensor	without wire end ferrule, tin-plated
Cable length sensor	3 m
Weight	0.459 kg

## Material

Housing material	Polyamide
Seal material	Acrylonitrile butadiene rubber
Material threaded bushing	Die cast zinc
Material front plate	Acrylonitrile butadiene styrene
Part No.	R412009388

## Technical information

The pressure dew point must be at least 15 °C less than ambient and medium temperature and may not exceed 3 °C.

Nominal flow Qn with secondary pressure p2 = 6 bar at  $\Delta p = 1$  bar

A change in the flow direction (from air supply on the left to air supply on the right) occurs by rotating installation by 180° about the vertical axis. Please see the operating instructions for further details.

The sensor signal is visible on the front of the cover.

Electronic sensor R412003658 included in scope of delivery (assembled).

An ST6 sensor (contactless) is used to detect the switching position in the non-actuated state (position: exhaust).

### 3/2-directional valve with pilot valve and port for electrical connector form C

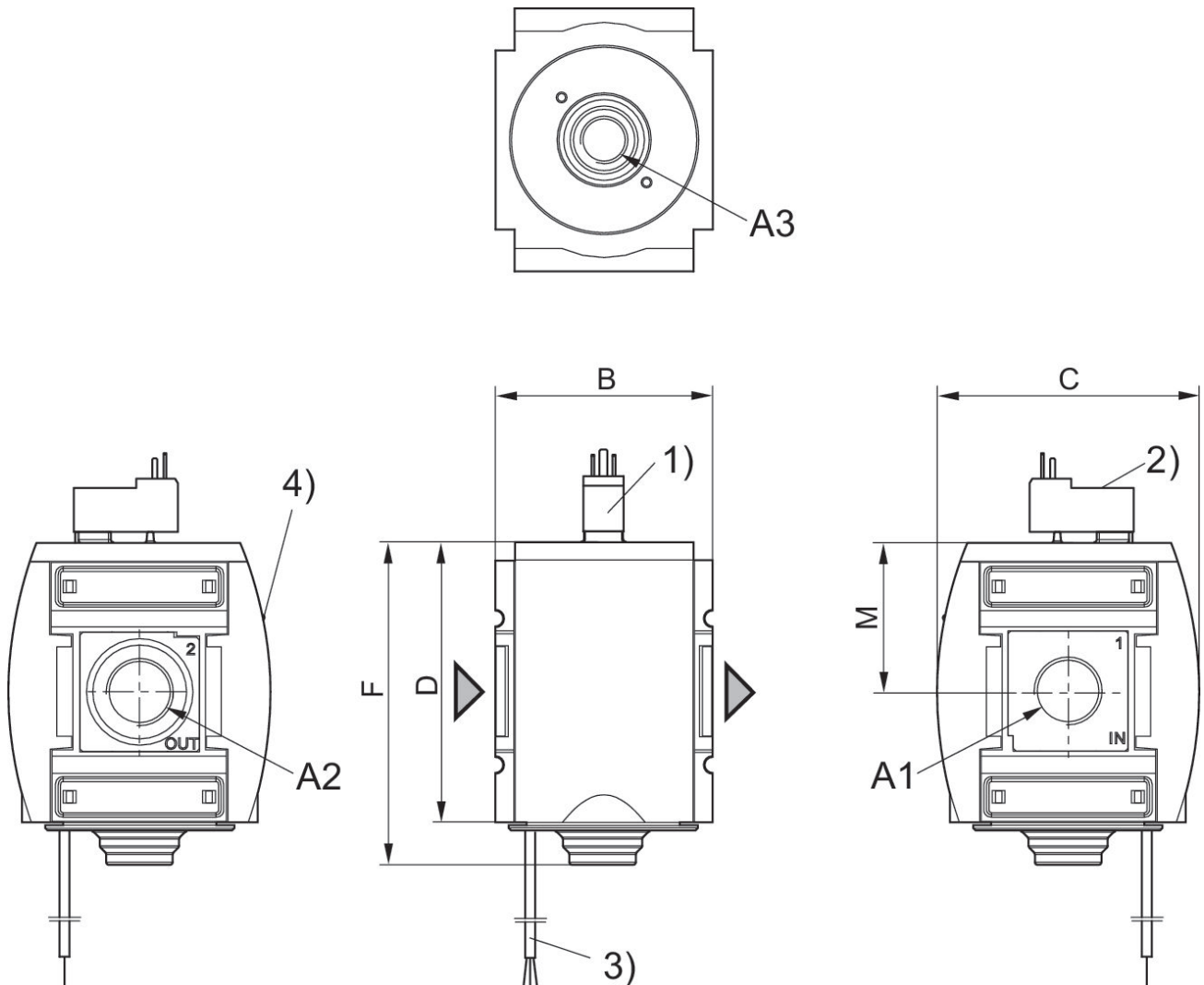

- A1 = input A2 = output A3 = ventilation port  
 1) Electr. connection: valve plug connector form C, ISO 15217  
 2) Manual override  
 3) For version with sensor: cable length 3 m PUR.  
 4) Optical switch status indicator

### Dimensions in mm

Part No.	A1	A2	A3	B	C	D	F	M
R412009382	G 3/4	G 3/4	G 1/2	85	103	109	125	58
R412009388	G 1	G 1	G 1/2	85	103	109	125	58

**Flow rate characteristic**  
 $p_2 = 0,05 - 7 \text{ bar}, 1 > 2$

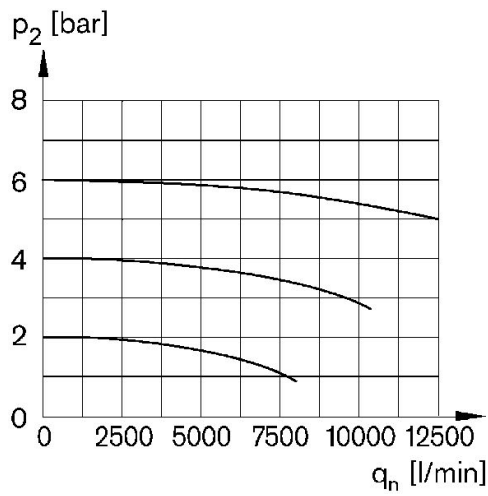

$p_2$  = Secondary pressure  
 $q_n$  = Nominal flow

**Rear exhaust**  
 $2 > 3$

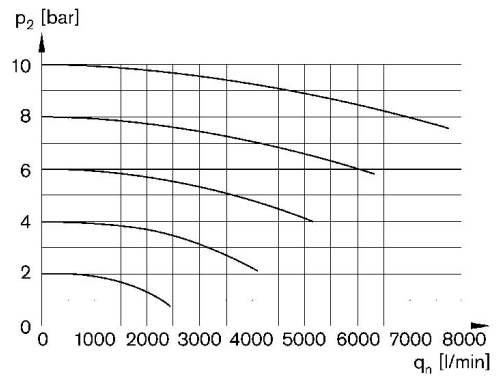

$p_2$  = Secondary pressure  
 $q_n$  = Nominal flow

**Sensor pin assignment, tin-plated wire ends**

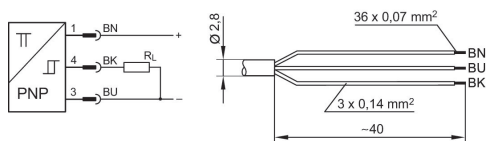

BN = brown  
 BK = black  
 BU = blue

## Accessories overview

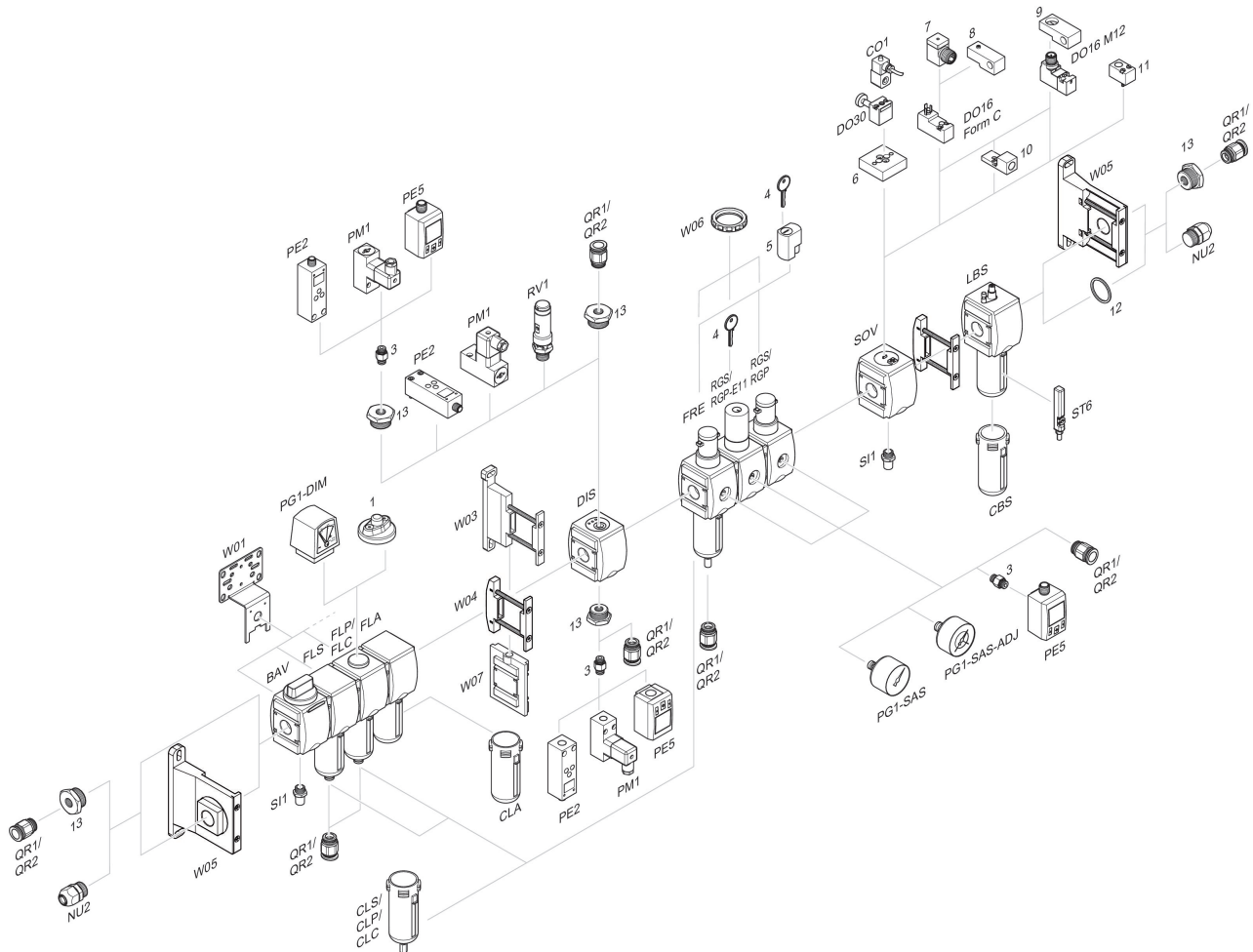

1 = contamination display 3 = Double nipple 4 = Key for E11 locking 5 = mortise lock 6 = Transition plate DO30 7 = Adapter, Series CON-VP 8 = Mounting aid DO16, form C 9 = Mounting aid DO16, M12 10 = Adapter for external pilot air 11 = Adapter pneumatic operation 12 = Sealing ring 13 = Reducing nipple