

3/2-directional valve, Series CD07

5772085280

General series information
AVENTICS Series CD07 Directional valves

- The AVENTICS Series CD consists of various spool valves with an extremely durable die-cast zinc housing. Its electrical, pneumatic, or mechanical actuating controls (roller, lever, pedal, or plunger) make the Series CD ideal for applications in harsh environments.
- For demanding environments

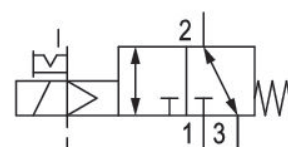

Technical data

Industry	Industrial
Activation	Electrically
Frame size	CD07
Valve type	Spool valve, positive overlapping
Switching principle	3/2, with spring return
Valve function	NC/NO
Actuating control	Single Solenoid
Sealing principle	soft seal
Connection type	Pipe connection
Manual override	with detent
Compressed air connection	G 1/4
Standard compressed air connection	according to ISO 228-1
Compressed air connection input	G 1/4
Compressed air connection output	G 1/4
Compressed air connection, exhaust	G 1/4
Pilot control exhaust	with directional pilot air exhaust
Compressed air connection pilot input	G 1/8
Compressed air connection pilot exhaust	M5

Nominal flow Qn	1400 l/min
Nominal flow Qn 1 to 2	1400 l/min
Nominal flow Qn 2 to 3	1400 l/min
Working pressure min.	-0.95 bar
Working pressure max	10 bar
Control pressure min.	3 bar
Control pressure max.	10 bar
Electrical connection type	Plug
Electrical connection size	EN 175301-803, form A
Connector standard	EN 175301-803:2006
Protection class with connection	IP65
Reverse polarity protection	Protected against polarity reversal
Operational voltage AC at 50 Hz	230 V
Voltage tolerance AC 50 Hz	-20% / +10%
Operational voltage AC at 60 Hz	230 V
Voltage tolerance AC 60 Hz	-10% / +20%
Pilot	External
Coil width	30 mm
Pilot valve width	30 mm
Compatibility index	13 14
Holding power AC 50 Hz	4.8 VA
Holding power AC 60 Hz	4.1 VA
Switch-on power AC 50 Hz	6.9 VA
Switch-on power AC 60 Hz	5.8 VA
Duty cycle	100 %
Typ. switch-on time	25 ms
Typ. switch-off time	45 ms
Temperature resistance	-25 °C cold-resistant
Min. ambient temperature	-25 °C
Max. ambient temperature	50 °C
Min. medium temperature	-25 °C
Max. medium temperature	50 °C
Medium	Compressed air
Oil content of compressed air min.	0 mg/m ³

Oil content of compressed air max.	1 mg/m ³
Max. particle size	50 µm
Weight	0.54 kg

Material

Housing material	Die cast zinc Polyamide fiber-glass reinforced
Seal material	Acrylonitrile butadiene rubber
Part No.	5772085280

Technical information

ATEX optional: ATEX version can be produced by combining the basic valve without coil with an ATEX coil. ATEX ID: see ATEX coils catalog page.

option valve: The input and output compressed air connections can be exchanged. The valve can thereby be used in the NC or NO operating mode.

The min. control pressure must be adhered to, since otherwise faulty switching and valve failure may result!

The pressure dew point must be at least 15 °C less than ambient and medium temperature and may not exceed 3 °C.

The oil content of compressed air must remain constant during the life cycle.

Use only the approved oils from AVENTICS. Further information can be found in the "Technical information" document (available in <https://www.emerson.com/en-us/support>).

Dimensions

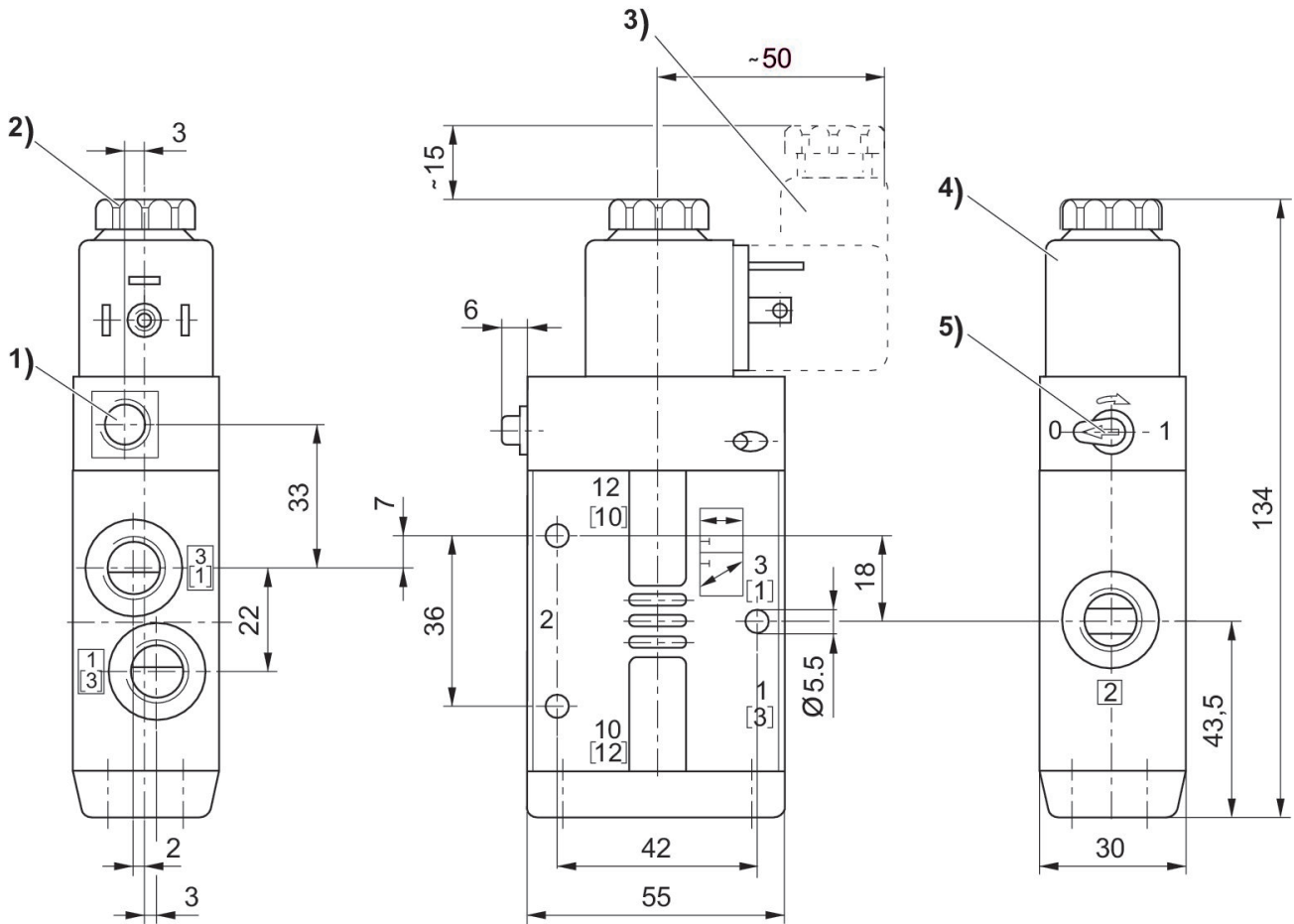

- 1) Only with separate pilot control G 1/8 2) After removal of cap M5 internal thread 3) Valve plug connector
4) Coil can be plugged at 45° intervals 5) Manual override