

# 3/2-directional valve, Series CD07

## 5772085302

General series information  
AVENTICS Series CD07 Directional valves

- The AVENTICS Series CD consists of various spool valves with an extremely durable die-cast zinc housing. Its electrical, pneumatic, or mechanical actuating controls (roller, lever, pedal, or plunger) make the Series CD ideal for applications in harsh environments.
- For demanding environments

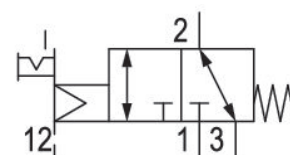

### Technical data

Industry

Activation

Frame size

Valve type

basic valve with electrical connector

Switching principle

Valve function

Actuating control

Sealing principle

Connection type

Manual override

Industrial

Electrically

CD07

Spool valve, positive overlapping

Basic valve without coil

3/2, with spring return

NC/NO

Single Solenoid

soft seal

Pipe connection

with detent

Compressed air connection

Standard compressed air connection

Compressed air connection input

Compressed air connection output

Compressed air connection, exhaust

Pilot control exhaust

Compressed air connection pilot input

Compressed air connection pilot exhaust

G 1/4

according to ISO 228-1

G 1/4

G 1/4

G 1/4

with directional pilot air exhaust

G 1/8

M5

Nominal flow Qn	1400 l/min
Nominal flow Qn 1 to 2	1400 l/min
Nominal flow Qn 2 to 3	1400 l/min
Working pressure min.	-0.95 bar
Working pressure max	10 bar
Control pressure min.	3 bar
Control pressure max.	10 bar
Electrical connection type	Plug
Electrical connection size	EN 175301-803, form A
Connector standard	EN 175301-803:2006
Reverse polarity protection	Protected against polarity reversal
Pilot	External
Pilot valve width	30 mm
Compatibility index	13 14
Duty cycle	100 %
Temperature resistance	-25 °C cold-resistant
Certificates	ATEX optional
ATEX	ATEX optional
Min. ambient temperature	-25 °C
Max. ambient temperature	50 °C
Min. medium temperature	-25 °C
Max. medium temperature	50 °C
Medium	Compressed air
Oil content of compressed air min.	0 mg/m <sup>3</sup>
Oil content of compressed air max.	1 mg/m <sup>3</sup>
Max. particle size	50 µm

## Material

Housing material	Die cast zinc Polyamide fiber-glass reinforced
Seal material	Acrylonitrile butadiene rubber

Part No.

5772085302

## Technical information

ATEX optional: ATEX version can be produced by combining the basic valve without coil with an ATEX coil. ATEX ID: see ATEX coils catalog page.

option valve: The input and output compressed air connections can be exchanged. The valve can thereby be used in the NC or NO operating mode.

The min. control pressure must be adhered to, since otherwise faulty switching and valve failure may result!

The pressure dew point must be at least 15 °C less than ambient and medium temperature and may not exceed 3 °C.

The oil content of compressed air must remain constant during the life cycle.

Use only the approved oils from AVENTICS. Further information can be found in the "Technical information" document (available in <https://www.emerson.com/en-us/support>).

## Dimensions

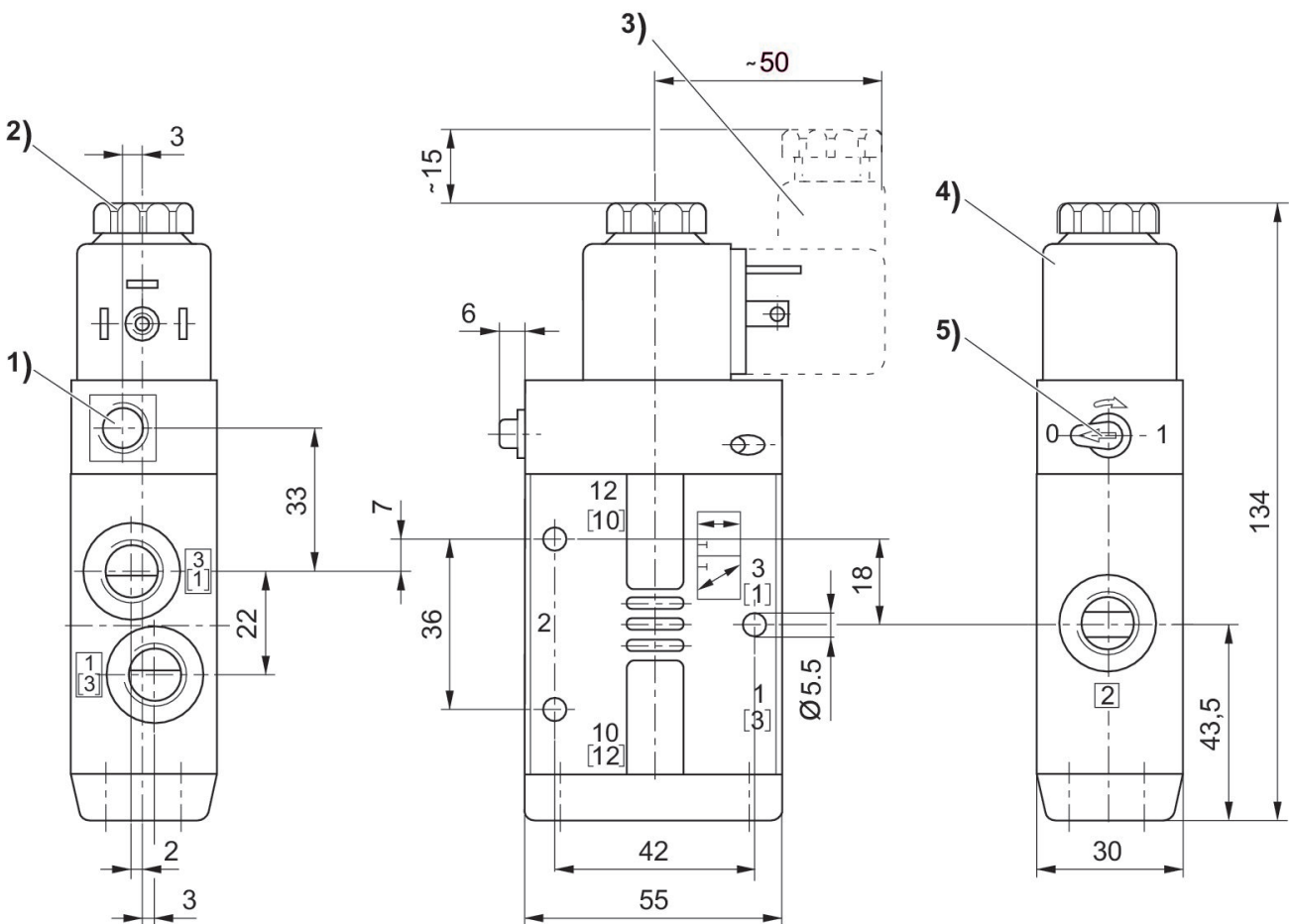

- 1) Only with separate pilot control G 1/8 2) After removal of cap M5 internal thread 3) Valve plug connector  
4) Coil can be plugged at 45° intervals 5) Manual override