

5/2-directional valve, Series CD07

5634630100

AVENTICS Series CD07 Directional valves

- $Q_n = 1200 \dots 1400 \text{ l/min}$

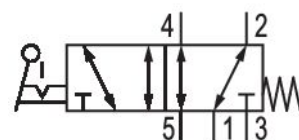

Technical data

Industry	Industrial
Activation	Mechanical
Frame size	CD07
Valve type	Spool valve, positive overlapping
Switching principle	5/2, with spring return
Actuating control	Single Solenoid
Plate connection	Pipe connection
Actuating element	Hand lever, with detent, without detent
Sealing principle	soft seal
Compressed air connection	G 1/4
Compressed air connection type	Internal thread
Compressed air connection input	G 1/4
Compressed air connection output	G 1/4
Compressed air connection, exhaust	G 1/4
Nominal flow Q_n	1200 l/min
Working pressure min.	-0.95 bar
Working pressure max	10 bar
actuating force min.	20 N

Certificates	Suitable for ATEX
ATEX	Suitable for ATEX
Min. ambient temperature	-25 °C
Max. ambient temperature	80 °C
Min. medium temperature	-25 °C
Max. medium temperature	80 °C
Medium	Compressed air
Oil content of compressed air min.	0 mg/m ³
Oil content of compressed air max.	1 mg/m ³
Max. particle size	50 µm
Weight	0.62 kg

Material

Housing material	Die cast zinc Polyamide fiber-glass reinforced
Seal material	Acrylonitrile butadiene rubber
Material actuating control	Polyoxymethylene
Part No.	5634630100

Technical information

The min. control pressure must be adhered to, since otherwise faulty switching and valve failure may result!

The pressure dew point must be at least 15 °C less than ambient and medium temperature and may not exceed 3 °C.

The oil content of compressed air must remain constant during the life cycle.

Use only the approved oils from AVENTICS. Further information can be found in the "Technical information" document (available in <https://www.emerson.com/en-us/support>).

Dimensions

Fig. 3

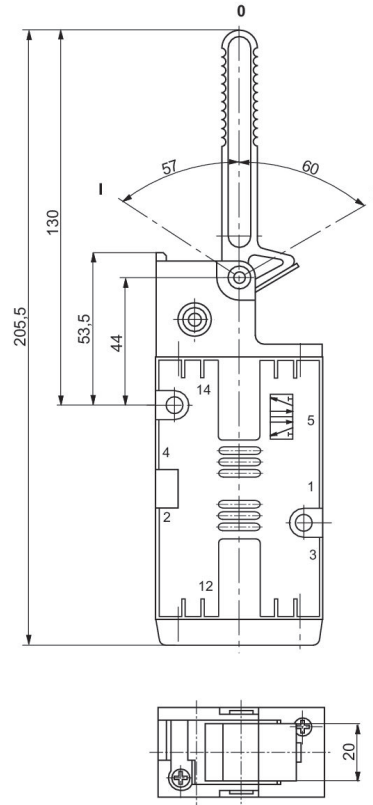

Position 0: initial position, position I: with detent, manual return, position II: automatic spring return.