

3/2-directional valve, Series CD12

5724560220

General series information Series CD12

- The AVENTICS Series CD consists of various spool valves with an extremely durable die-cast zinc housing. Its electrical, pneumatic, or mechanical actuating controls (roller, lever, pedal, or plunger) make the Series CD ideal for applications in harsh environments.

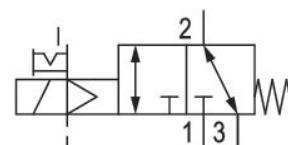

Technical data

Industry
Industrial

Activation
Electrically

Nominal flow Qn
4000 l/min

Switching principle
3/2

Version
NC/NO

Compressed air connection output
G 1/2

Working pressure min.
-0.95 bar

Working pressure max.
16 bar

DC operating voltage
24 V

Pilot valve width
30 mm

Valve type
Spool valve, positive overlapping

Connection type
Pipe connection

Control pressure min.
2 bar

Control pressure max.
10 bar

Voltage tolerance DC
-10% / +10%

Manual override
with detent
without detent

Electrical connection type
Plug

Electrical connection size
EN 175301-803, form A

Electrical connection number of poles
3-pin

Actuating control
Single Solenoid

Sealing principle
Soft Seal

Pilot
External

Return
With spring return

Temperature resistance
-25 °C cold-resistant

Min. ambient temperature
-25 °C

Max. ambient temperature
50 °C

Min. medium temperature
-25 °C

Max. medium temperature
50 °C

Medium
Compressed air

Max. particle size
50 µm

Oil content of compressed air min.
0 mg/m³

Oil content of compressed air max.
1 mg/m³

Standard compressed air connection
according to ISO 228-1

Compressed air connection input
G 1/2

Compressed air connection, exhaust
G 1/2

Compressed air connection pilot input
G 1/8

Compressed air connection pilot exhaust
M5

Pilot control exhaust
with directional pilot air exhaust

Nominal flow Qn 1 to 2
4000 l/min

Nominal flow Qn 2 to 3
4000 l/min

Power consumption DC
2.1 W

Compatibility index
13
14

Duty cycle
100 %

Typ. switch-on time
34 ms

Typ. switch-off time
90 ms

Pilot valve width
30 mm

Connector standard
EN 175301-803:2006

Protection class with connection
IP65

Reverse polarity protection
Protected against polarity reversal

Weight
0.85 kg

Housing material
Aluminum
Polyamide fiber-glass reinforced

Seal material
Acrylonitrile butadiene rubber

Polyurethane

Part No.
5724560220

Technical information

ATEX optional: ATEX version can be produced by combining the basic valve without coil with an ATEX coil. ATEX ID: see ATEX coils catalog page.

option valve: The input and output compressed air connections can be exchanged. The valve can thereby be used in the NC or NO operating mode.

*Note: Basic valves feature a maximum working pressure of 16 bar. When combined with standard CNOMO pilots, the maximum working pressure is 10 bar.

The min. control pressure must be adhered to, since otherwise faulty switching and valve failure may result!

The pressure dew point must be at least 15 °C under ambient and medium temperature and may not exceed 3 °C .

The oil content of compressed air must remain constant during the life cycle.

Use only the approved oils from AVENTICS. Further information can be found in the “Technical information” document (available in <https://www.emerson.com/en-us/support>).

Dimensions

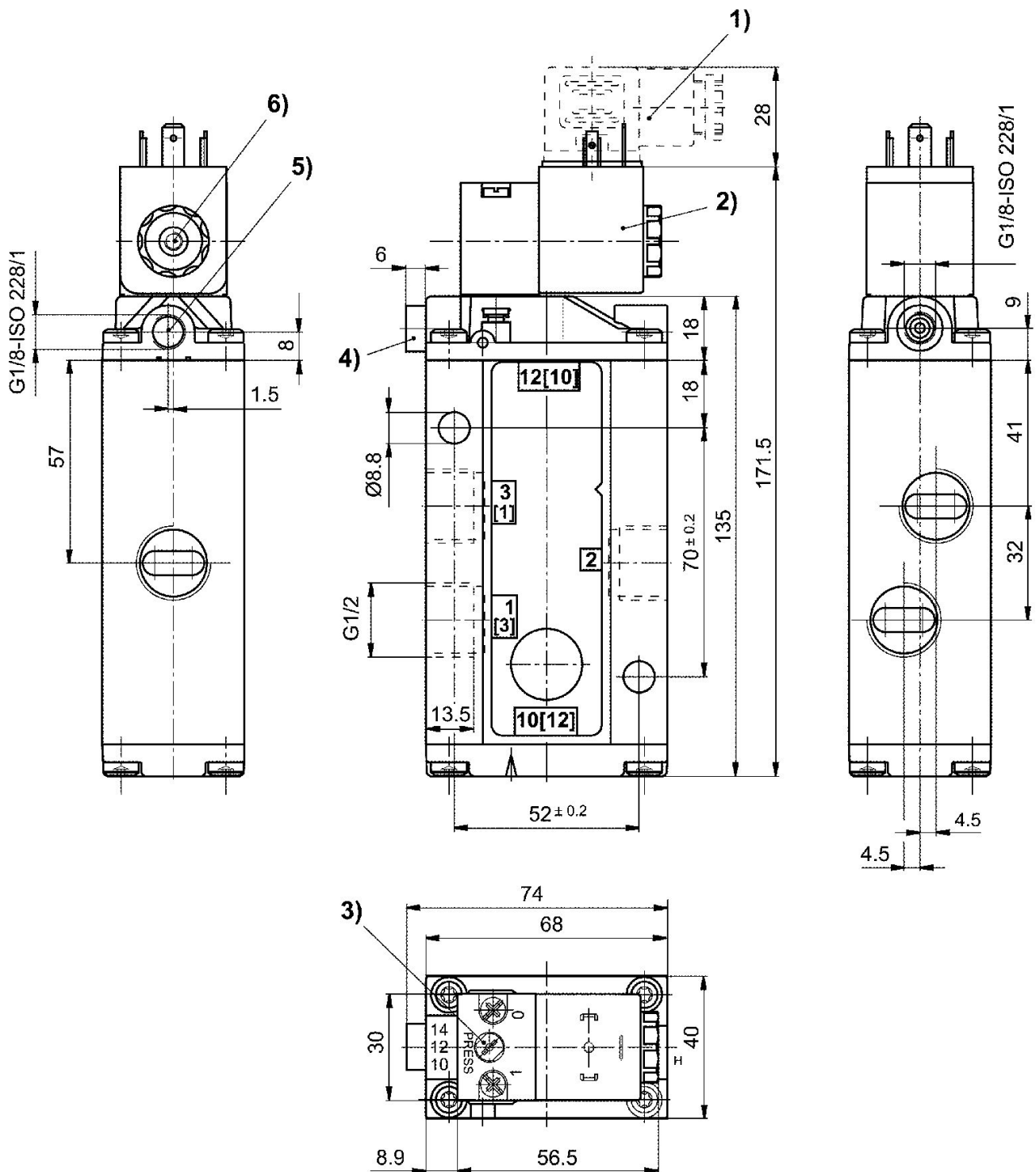

- 1) Valve plug connector 2) Coil can be rotated at 90° intervals 3) Manual override
4) Port X (only for externally piloted valves) 5) Exhaust port of piston 6) Pilot valve exhaust, M5