

5/2-directional valve, Series CD12

R412013344

Series CD12

- $Q_n = [[3600 \dots 4100] \text{ l/min}]$

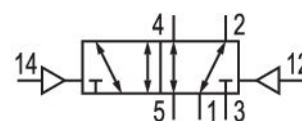

Technical data

Industry	Industrial
Activation	Pneumatically
Valve type	Spool valve, positive overlapping
Sealing principle	soft seal
Connection type	Pipe connection
Compressed air connection input	M22x1,5
Compressed air connection output	M22x1,5
Compressed air connection, exhaust	M22x1,5
Compressed air connection pilot input	G 1/8
Nominal flow Q_n	4100 l/min
Working pressure min.	-0.95 bar
Working pressure max.	16 bar

Control pressure min.	2 bar
Control pressure max.	10 bar
ATEX	Suitable for ATEX
Min. ambient temperature	-25 °C
Max. ambient temperature	70 °C
Min. medium temperature	-25 °C
Max. medium temperature	70 °C
Medium	Compressed air
Oil content of compressed air min.	0 mg/m ³
Oil content of compressed air max.	1 mg/m ³
Max. particle size	50 µm
Weight	0.86 kg

Material

Housing material	Aluminum Polyamide fiber-glass reinforced
Seal material	Acrylonitrile butadiene rubber Polyurethane
Part No.	R412013344

Technical information

The min. control pressure must be adhered to, since otherwise faulty switching and valve failure may result!

The pressure dew point must be at least 15 °C less than ambient and medium temperature and may not exceed 3 °C.

The oil content of compressed air must remain constant during the life cycle.

Use only the approved oils from AVENTICS. Further information can be found in the "Technical information" document (available in <https://www.emerson.com/en-us/support>).

Dimensions

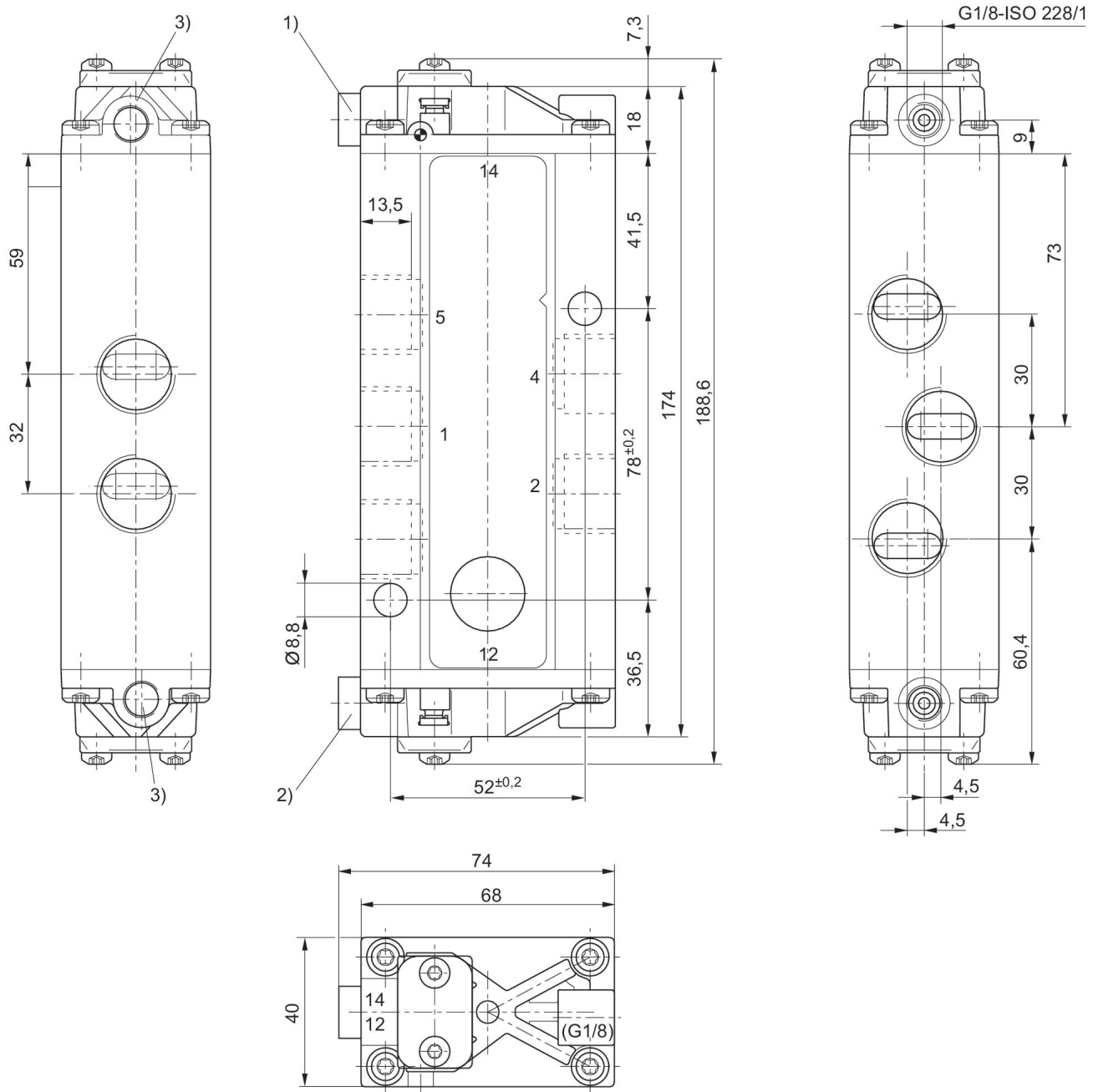

1) Port 14 2) Port 12 3) Port without function