

5/2-directional valve, Series CD12

R412013341

General series information
Series CD12

- The AVENTICS Series CD consists of various spool valves with an extremely durable die-cast zinc housing. Its electrical, pneumatic, or mechanical actuating controls (roller, lever, pedal, or plunger) make the Series CD ideal for applications in harsh environments.

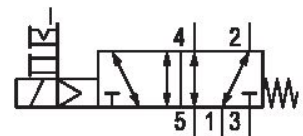

Technical data

Industry
Industrial

Activation
Electrically

Nominal flow Q_n
4100 l/min

Switching principle
5/2

Compressed air connection output
M22x1,5

Working pressure min.
2 bar

Working pressure max
10 bar

DC operating voltage
24 V

Voltage tolerance DC
-10% / +10%

Electrical connection type
Plug

Electrical connection size
EN 175301-803, form A

Electrical connection number of poles
3-pin

Actuating control
Single Solenoid

Sealing principle
Soft Seal

Pilot
Internal

Pilot valve width

30 mm

Valve type

Spool valve, positive overlapping

Connection type

Pipe connection

Control pressure min.

2 bar

Control pressure max.

10 bar

Min. ambient temperature

-15 °C

Max. ambient temperature

50 °C

Min. medium temperature

-15 °C

Compressed air connection input

M22x1,5

Compressed air connection, exhaust

M22x1,5

Power consumption DC

2.1 W

Compatibility index

13

14

Pilot valve width

30 mm

Protection class with connection

IP65

Housing material

Aluminum

Polyamide fiber-glass reinforced

Seal material

Acrylonitrile butadiene rubber

Return

With spring return

Temperature resistance

-25 °C cold-resistant

Max. medium temperature

50 °C

Medium

Compressed air

Max. particle size

50 µm

Oil content of compressed air min.

0 mg/m³

Oil content of compressed air max.

1 mg/m³

Compressed air connection pilot exhaust

M5

Pilot control exhaust

with directional pilot air exhaust

Duty cycle

100 %

Typ. switch-on time

37 ms

Typ. switch-off time

97 ms

Reverse polarity protection

Protected against polarity reversal

Weight

1 kg

Polyurethane

Part No.

R412013341

Technical information

*Note: Basic valves feature a maximum working pressure of 16 bar. When combined with standard CNOMO pilots, the maximum working pressure is 10 bar.

The min. control pressure must be adhered to, since otherwise faulty switching and valve failure may result!

The pressure dew point must be at least 15 °C under ambient and medium temperature and may not exceed 3 °C .

The oil content of compressed air must remain constant during the life cycle.

Use only the approved oils from AVENTICS. Further information can be found in the “Technical information” document (available in <https://www.emerson.com/en-us/support>).

Dimensions

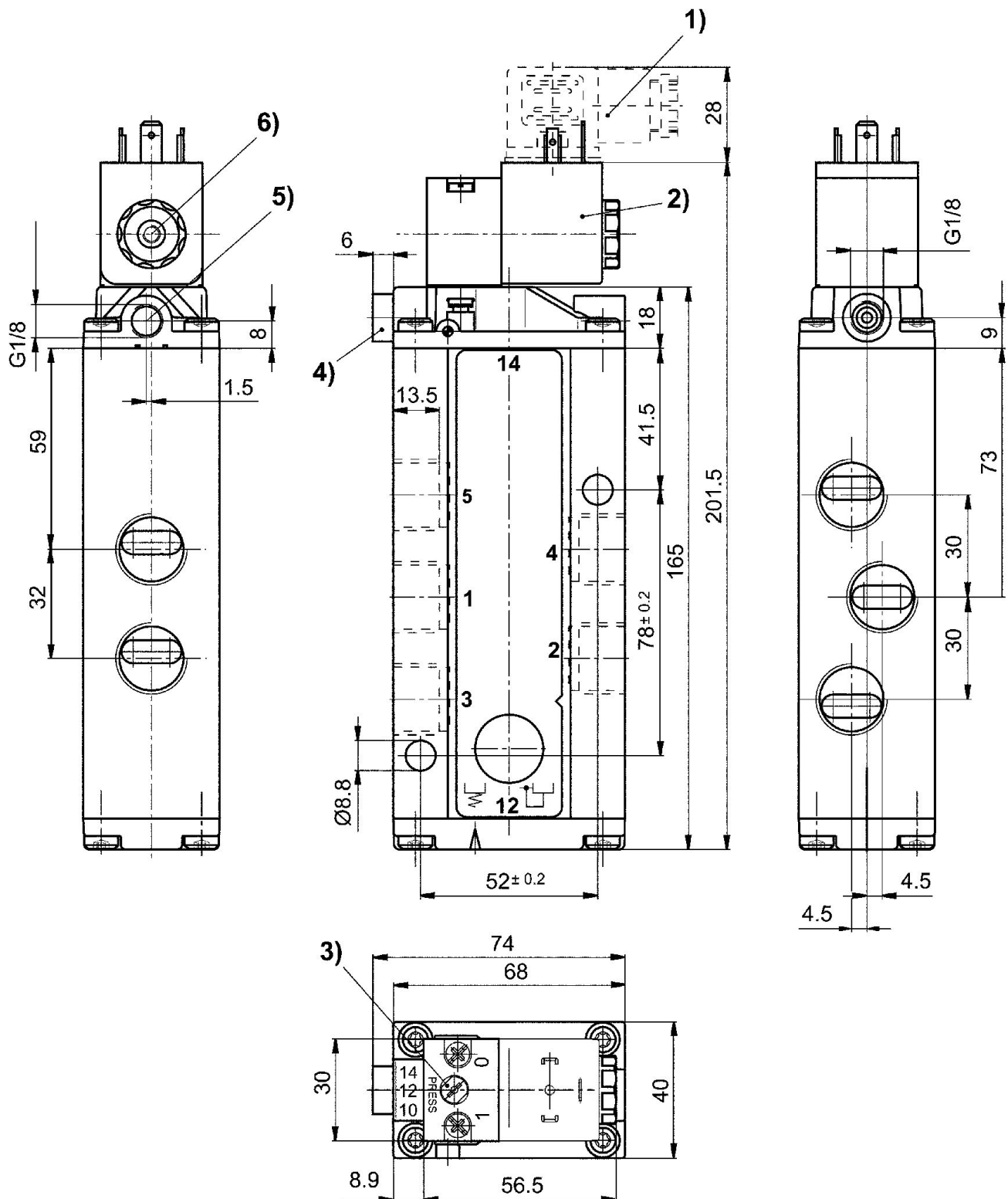

- 1) Valve plug connector 2) Coil can be rotated at 90° intervals 3) Manual override
4) Port X (only for externally piloted valves) 5) Exhaust port of piston 6) Pilot valve exhaust, M5