

# 5/2-directional valve, Series CD12

5725485280

## General series information Series CD12

- The AVENTICS Series CD consists of various spool valves with an extremely durable die-cast zinc housing. Its electrical, pneumatic, or mechanical actuating controls (roller, lever, pedal, or plunger) make the Series CD ideal for applications in harsh environments.

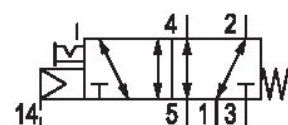

## Technical data

Industry  
Industrial

Activation  
Electrically

Nominal flow Q<sub>n</sub>  
4100 l/min

Switching principle  
5/2

Compressed air connection output  
G 1/2

Working pressure min.  
-0.95 bar

Working pressure max  
16 bar

Operational voltage AC at 50 Hz  
230 V

Operational voltage AC at 60 Hz  
230 V

Voltage tolerance AC 50 Hz  
-20% / +10%

Voltage tolerance AC 60 Hz  
-10% / +20%

Manual override  
with detent  
without detent

Electrical connection type  
Plug

Electrical connection size  
EN 175301-803, form A

Electrical connection number of poles  
3-pin

Actuating control  
Single Solenoid

Sealing principle  
Soft Seal

Pilot  
External

**Pilot valve width**

30 mm

**Valve type**

Spool valve, positive overlapping

**Control pressure min.**

2 bar

**Control pressure max.**

10 bar

**Min. ambient temperature**

-15 °C

**Max. ambient temperature**

50 °C

**Min. medium temperature**

-15 °C

**Standard compressed air connection**

according to ISO 228-1

**Compressed air connection input**

G 1/2

**Compressed air connection, exhaust**

G 1/2

**Holding power AC 50 Hz**

4.4 VA

**Holding power AC 60 Hz**

3.5 VA

**Switch-on power AC 50 Hz**

6.9 VA

**Switch-on power AC 60 Hz**

6.2 VA

**Pilot valve width**

30 mm

**Protection class with connection**

IP65

**Housing material**

Aluminum

Polyamide fiber-glass reinforced

**Seal material**

Acrylonitrile butadiene rubber

**Connection type**

Pipe connection

**Return**

With spring return

**Max. medium temperature**

50 °C

**Medium**

Compressed air

**Max. particle size**

50 µm

**Oil content of compressed air min.**

0 mg/m<sup>3</sup>

**Oil content of compressed air max.**

1 mg/m<sup>3</sup>

**Compressed air connection pilot input**

G 1/8

**Compressed air connection pilot exhaust**

M5

**Pilot control exhaust**

with directional pilot air exhaust

**Compatibility index**

13

14

**Duty cycle**

100 %

**Typ. switch-on time**

37 ms

**Typ. switch-off time**

97 ms

**Reverse polarity protection**

Protected against polarity reversal

**Weight**

1 kg

Polyurethane

**Part No.**

5725485280

## Technical information

ATEX optional: ATEX version can be produced by combining the basic valve without coil with an ATEX coil. ATEX ID: see ATEX coils catalog page.

\*Note: Basic valves feature a maximum working pressure of 16 bar. When combined with standard CNOMO pilots, the maximum working pressure is 10 bar.

The min. control pressure must be adhered to, since otherwise faulty switching and valve failure may result!

The pressure dew point must be at least 15 °C under ambient and medium temperature and may not exceed 3 °C .

The oil content of compressed air must remain constant during the life cycle.

Use only the approved oils from AVENTICS. Further information can be found in the "Technical information" document (available in <https://www.emerson.com/en-us/support>).

## Dimensions

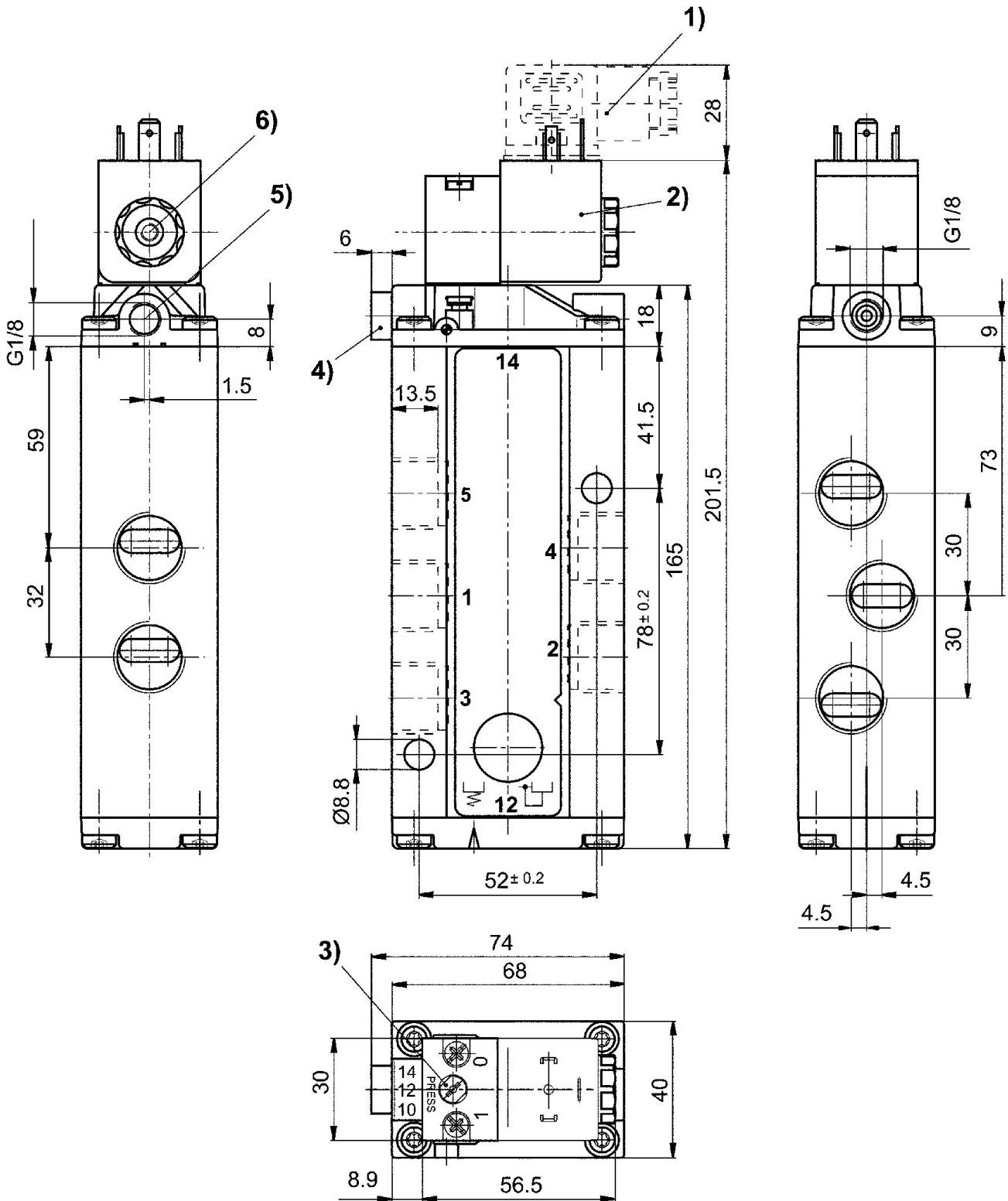

- 1) Valve plug connector 2) Coil can be rotated at 90° intervals 3) Manual override  
4) Port X (only for externally piloted valves) 5) Exhaust port of piston 6) Pilot valve exhaust, M5