

AVENTICS Guide units

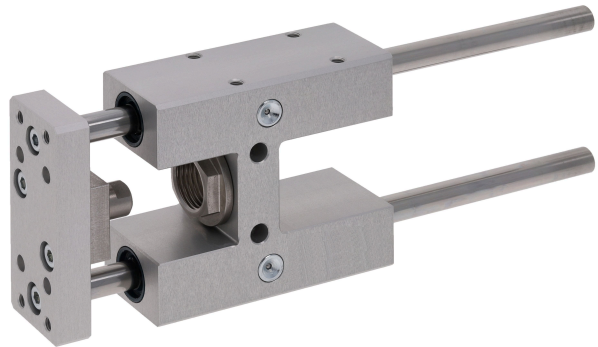

Technical data

| | |
|--------------------------|---------------|
| Industry | Industrial |
| Piston Ø | 25 mm |
| Stroke | 100 mm |
| Bearing type | Plain bearing |
| For standard cylinders | ISO 6432 |
| Min. ambient temperature | -20 °C |
| Max. ambient temperature | 80 °C |
| Weight 0 mm stroke | 0.73 kg |
| Weight +10 mm stroke | 0.0122 kg |

Material

| | |
|--|-----------------------------|
| Bearing housings | Aluminum |
| Surface bearing housing | colorless anodized |
| Bearing type | Sintered bronze |
| Carrying plate | Aluminum |
| Surface carrying plate | colorless anodized |
| Material flexible coupling in carrying plate | Stainless Steel |
| Material guide rods | Hardened heat-treated steel |
| Surface guide rods | ground |

Part No.

0821401211

Technical information

Guide units for cylinder \varnothing 12 also fit on cylinder \varnothing 16

Dimensions

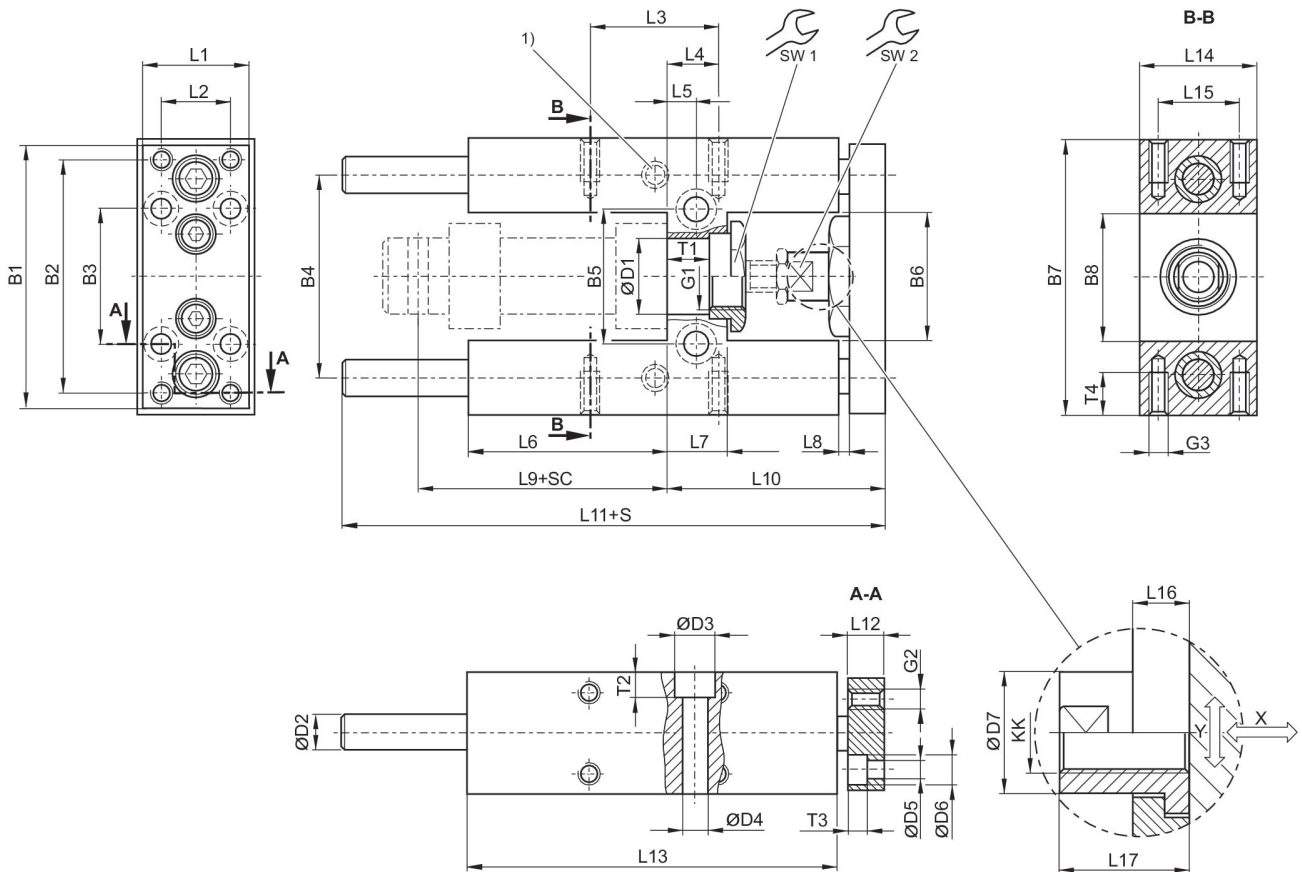

- 1) Lube nipple
- S = stroke
- SC = cylinder stroke
- X = max. play (axial)
- Y = min. play (radial)

| Piston \varnothing | Part No. | B1 | B2 | B3 | B4 | B5 | B6 | B7 | B8 |
|----------------------|------------|----|----|----|----|----|----|----|----|
| 12 | 0821401295 | 63 | 54 | 32 | 46 | 24 | 27 | 65 | 27 |
| 20 | 0821401200 | 76 | 68 | 40 | 58 | 38 | 37 | 79 | 37 |
| 25 | 0821401210 | 76 | 68 | 40 | 58 | 38 | 37 | 79 | 37 |

| Piston \varnothing | D1 | D2 | D3 | D4 | D5 | D6 | D7 | G1 | G2 |
|----------------------|-------|----|----|-----|-----|------|------|---------|----|
| 12 | 16 H7 | 8 | - | 5.5 | 4.5 | 8 | 10 | M16x1,5 | M4 |
| 20 | 22 H7 | 10 | 11 | 6.6 | 5.5 | 10.5 | 14.5 | M22x1,5 | M5 |

| Piston Ø | D1 | D2 | D3 | D4 | D5 | D6 | D7 | G1 | G2 |
|----------|-------|----|----|-----|-----|------|------|---------|----|
| 25 | 22 H7 | 10 | 11 | 6.6 | 5.5 | 10.5 | 14.5 | M22x1,5 | M5 |

| Piston Ø | G3 | KK | L1 | L2 | L3 | L4 | L5 | L6 | L7 |
|----------|----|----------|----|----|------|----|-----|----|----|
| 12 | M4 | M6 | 27 | 15 | 32.5 | 11 | 6.5 | 37 | 13 |
| 20 | M6 | M8 | 32 | 20 | 32.5 | 15 | 8.5 | 58 | 17 |
| 25 | M6 | M10x1,25 | 32 | 20 | 32.5 | 15 | 8.5 | 58 | 17 |

| Piston Ø | L8 | L9 | L10 | L11 | L12 | L13 | L14 | L15 | L16 |
|----------|----|------|-----|-------|-----|-----|-----|-----|-----|
| 12 | 3 | 52.6 | 51 | 133 | 10 | 75 | 30 | 22 | 7 |
| 20 | 3 | 71 | 65 | 160.5 | 12 | 108 | 34 | 23 | 6 |
| 25 | 3 | 76 | 65 | 160.5 | 12 | 108 | 34 | 23 | 6 |

| Piston Ø | L17 | SW1 | SW2 | T1 | T2 | T3 | T4 |
|----------|-----|-----|-----|------|----|-----|----|
| 12 | 18 | 19 | 8 | 10.6 | – | 4.6 | 8 |
| 20 | 22 | 27 | 13 | 11 | 7 | 5.7 | 14 |
| 25 | 17 | 27 | 13 | 11 | 7 | 5.7 | 14 |

Useful load

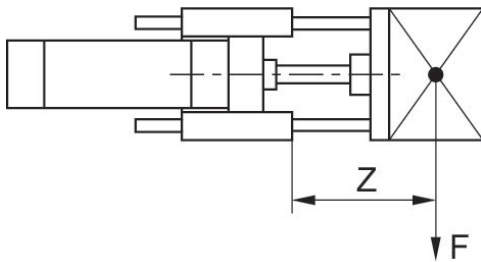

F = Useful load, Z = Projection

Useful load

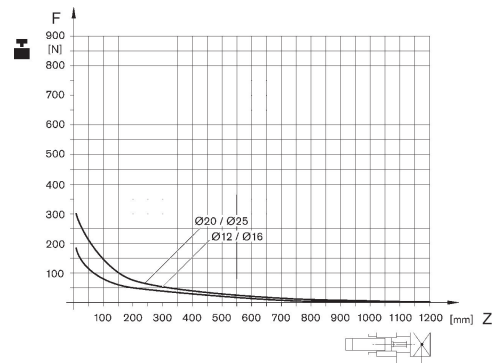

F = Useful load, Z = Projection

Bending due to 10 N load

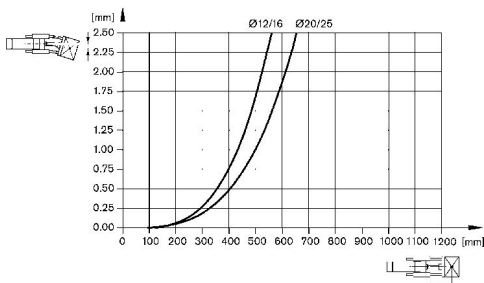

Bending due to own load

