

AVENTICS Series CL03-EV Directional valves

The AVENTICS Series CL03-EV spool valves are hygienically designed. They easily resist wet cleaning with aggressive cleaning detergents. The Series complies with protection class IP69K, is suitable for class NSF-H1 lubricants and designed for intensive application in the food and beverage industry.



Technical data

Industry	Industrial
Activation	Electrically
Note	Housing
Sealing principle	Soft seal
Connection type	Plate connection

Compressed air connection input	G 1/8
Compressed air connection output	G 1/8
Compressed air connection, exhaust	G 1/8
Compressed air connection pilot input	M5
Compressed air connection pilot exhaust	M5

Nominal flow Qn 700 l/min

Min. working pressure -0.9 bar
Max. working pressure 10 bar

Protection class with connection IP65
IP67

Directional valves, Series CL03-EV

2024-04-02

R412026370

	IP69K
LED status display	Yellow
Duty cycle	100 %
suitable for use in food processing	suitable for use in food processing
Certificates	UR (Underwriters Laboratories)
Min. ambient temperature	0 °C
Max. ambient temperature	50 °C
Min. medium temperature	0 °C
Max. medium temperature	50 °C
Medium	Compressed air
Min. oil content of compressed air	0 mg/m ³
Max. oil content of compressed air	5 mg/m ³
Max. particle size	50 µm
Mounting screws	M5
Mounting screw tightening torque	2 Nm
Weight	0.247 kg
Material	
Housing material	Polyamide fiber-glass reinforced
Seal material	Hydrogenated acrylonitrile butadiene rubber
Part No.	R412026370

Technical information

For series QR2 fittings, see “Pneumatic connection technologies”.

The valve housing is supplied without a valve and has to be ordered separately. See accessories “Base plate valves, electrically operated”

Closed exhaust outlets will lead to air congestion and valve damage. The “VENT” connection in the base plate must also not be closed.

Connect the “VENT” connection to a tube that exhausts the air outside the wet zone. If the valve is mounted in a protected area, for example in a control cabinet, you can also connect a silencer to the “VENT” connection.

The min. control pressure must be adhered to, since otherwise faulty switching and valve failure may result!

The pressure dew point must be at least 15 °C less than ambient and medium temperature and may not exceed 3 °C.

The oil content of compressed air must remain constant during the life cycle.

Use only the approved oils from AVENTICS. Further information can be found in the “Technical information” document (available in <https://www.emerson.com/en-us/support>).

The pilot valve is UL certified (Underwriters Laboratories recognized).

Directional valves, Series CL03-EV

2024-04-02

R412026370

Dimensions

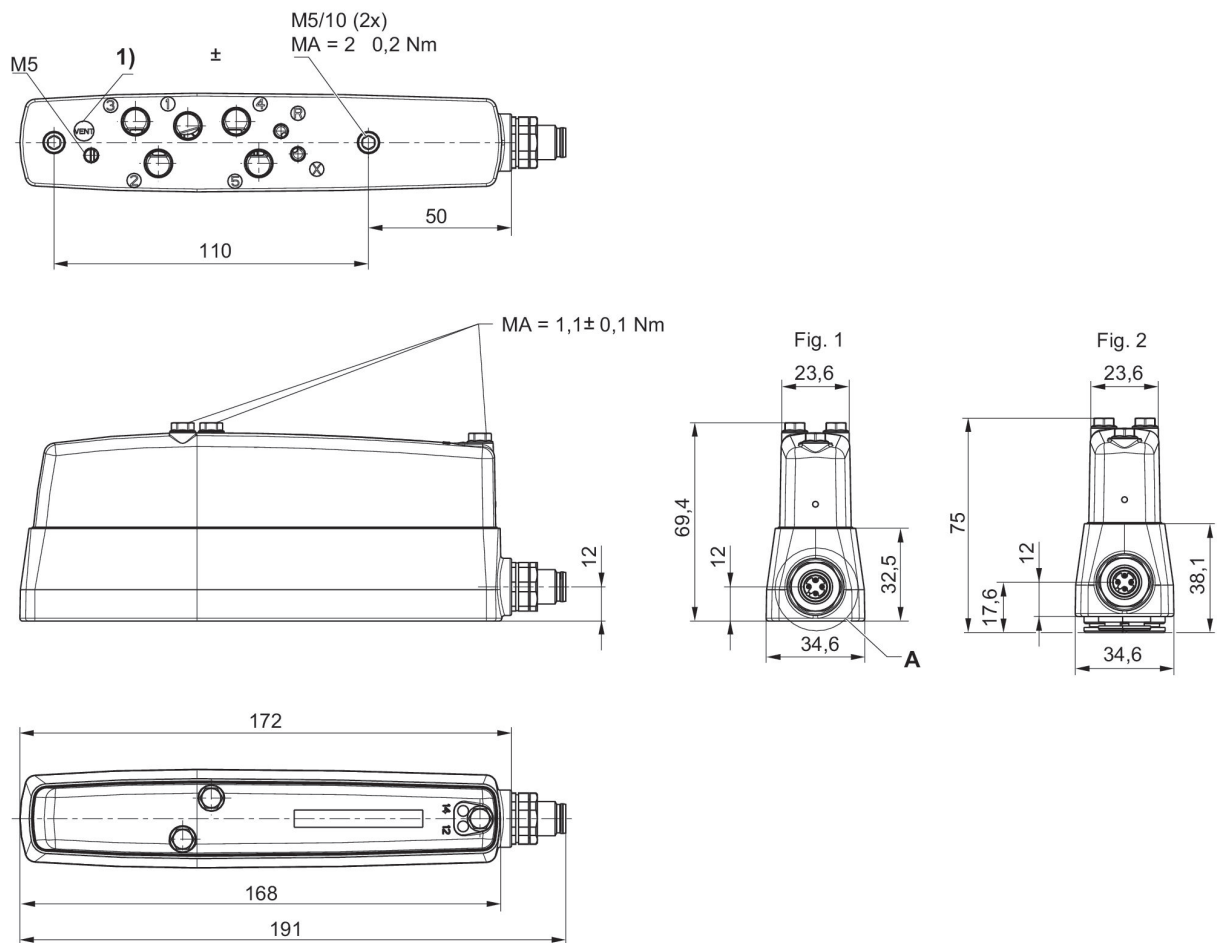

X Ventilation connection (VENT)

R412026370

Electrical connection:

round plug

A-coded

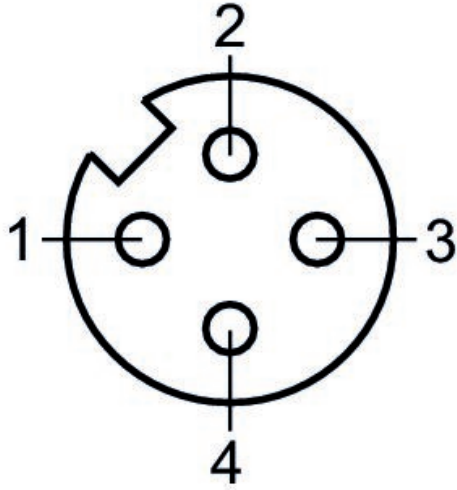

-
- 1) not assigned
 - 2) Coil 12
 - 3) Ground
 - 4) Coil 14