

Stainless Steel Round Cylinder, Series CSL-RD

R481624897

General series information Series CSL-RD

- The AVENTICS Series CSL-RD (ISO 6432) cylinder is a stainless-steel round cylinder, configurable in three different designs: standard, hygienic and short. The Series CSL-RD (ISO 6432) has a smooth profile and low surface roughness made of stainless steel, NSF-H1 grease and FDA compliant seals it is suitable for food contact. In addition, the cylinders are certified in accordance with regulation (EC) No 1935/2004.
- Clean and compact design
- The undercut-free scrapers prevent the accumulation of dirt and dead space around the piston rod
- Guaranteed food safety
- Resistant to chemicals
- Offers piston diameters from 16 mm to 63 mm
- Configurations available as single piston rod, elastic/ pre-adjusted/ manual adjusted cushioning, with magnetic detection, ATEX

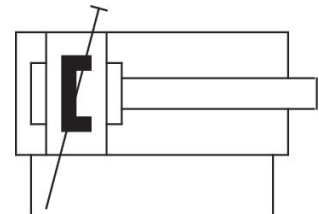
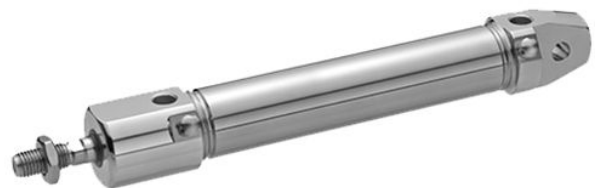

Technical data

Industry
Industrial

Type
Version: hygienic design

Piston Ø
32 mm

Stroke
50 mm

Functional principle
Double-acting

Cushioning
Pneumatic pre-adjusted cushioning

Magnetic piston
Piston with magnet

Environmental requirements
Industry standard
suitable for use in food processing

Piston rod
single

Scraper
Heat-Resistant Scraper

Pressure for determining piston forces
6,3 bar

Retracting piston force 435 N	Weight 0 mm stroke 0.699 kg
Extracting piston force 505 N	Weight +10 mm stroke 0.015 kg
Min. ambient temperature -20 °C	Stroke max. 1200 mm
Max. ambient temperature 80 °C	Medium Compressed air
Working pressure min. 1 bar	Min. medium temperature -20 °C
Working pressure max 10 bar	Max. medium temperature 80 °C
Ports G 1/8	Max. particle size 50 µm
Piston rod thread M10x1,25	Oil content of compressed air min. 0 mg/m ³
Cushioning length 16 mm	Oil content of compressed air max. 5 mg/m ³
Cushioning energy 3.4 J	Clamping piece for magnetic field sensor necessary Clamping piece for magnetic field sensor necessary

Material

Piston rod Stainless Steel	End cover Stainless Steel
Piston material Aluminum	Piston seal Nitrile butadiene rubber
Scraper material Thermoplastic polyurethane (TPU) Ultra-high-molecular-weight polyethylene (UHMW-PE)	Nut for cylinder mounting Stainless Steel
Material, front cover Stainless Steel	Nut for piston rod Stainless Steel
Cylinder tube Stainless Steel	Guide bushing Plastic
	Part No. R481624897

Technical information

ATEX-certified cylinders with identification II 2G Ex h IIC T4 Gb / II 2D Ex h IIIC T135°C Db_X can be generated in the Internet configurator.

The operating temperature range for ATEX-certified cylinders is -20°C ... 60°C.

The pressure dew point must be at least 15 °C under ambient and medium temperature and may not exceed 3 °C .

The oil content of compressed air must remain constant during the life cycle.

Use only the approved oils from AVENTICS. Further information can be found in the "Technical information" document (available in <https://www.emerson.com/en-us/support>).

Dimensions

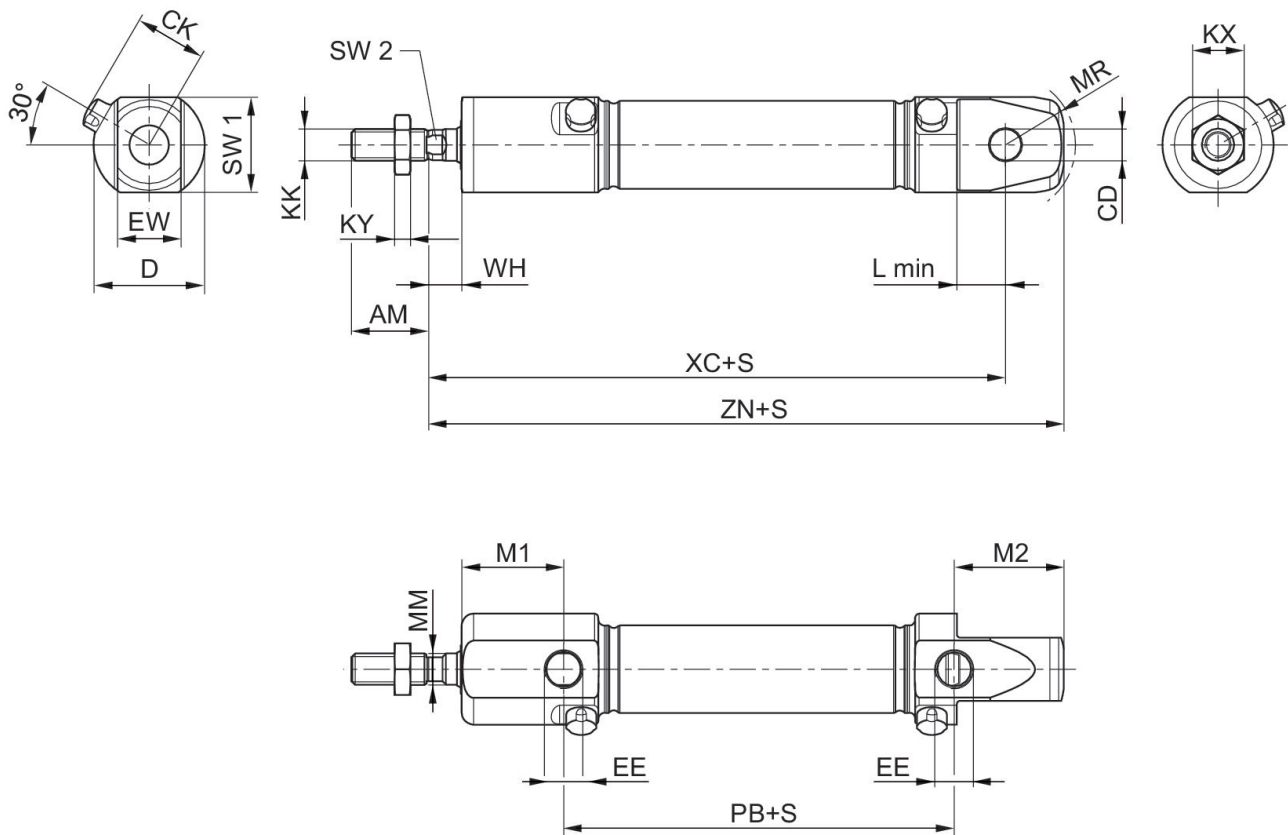

S = stroke

Piston Ø	AM-2	CD H9	CK	D	EE	EW d13	KK	KX	KY
16	16	6	14,7	22	M5	12	M6	10	3,2
20	20	8	17,9	28	G 1/8	16	M8	13	4
25	22	8	20,2	33	G 1/8	16	M10x1,25	17	5
32	22	10	21,5	38	G 1/8	16	M10x1,25	17	5
40	24	12	27	49	G 1/4	18	M12x1,25	18	6

Piston Ø	L min	M1	M2	MM f8	MR	PB ±1	WH ±1,2	XC ±1	ZN ± 1
16	9	21,2	22,7	6	16	43,6	7,5	82	94,7
20	12	25,7	27,7	8	18	48,6	8	95	109,7
25	12	28,2	29,7	10	19	51,8	9,5	104	119,7
32	14	34,6	11,7	12		46	8,9	117,5	129,5
40	16	38	8,7	16		66	10,8	139,6	153,5

Piston Ø	SW 1	SW 2
16	20	5
20	24	6
25	28	8
32	35	10

Piston Ø	SW 1	SW 2
40	45	13

Cushioning diagram

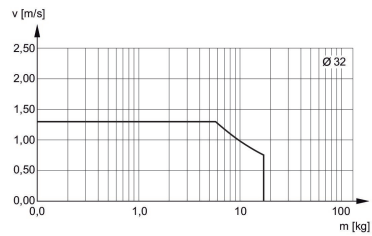

v = Piston velocity [m/s] m = Cushionable mass [kg]

Overview drawing

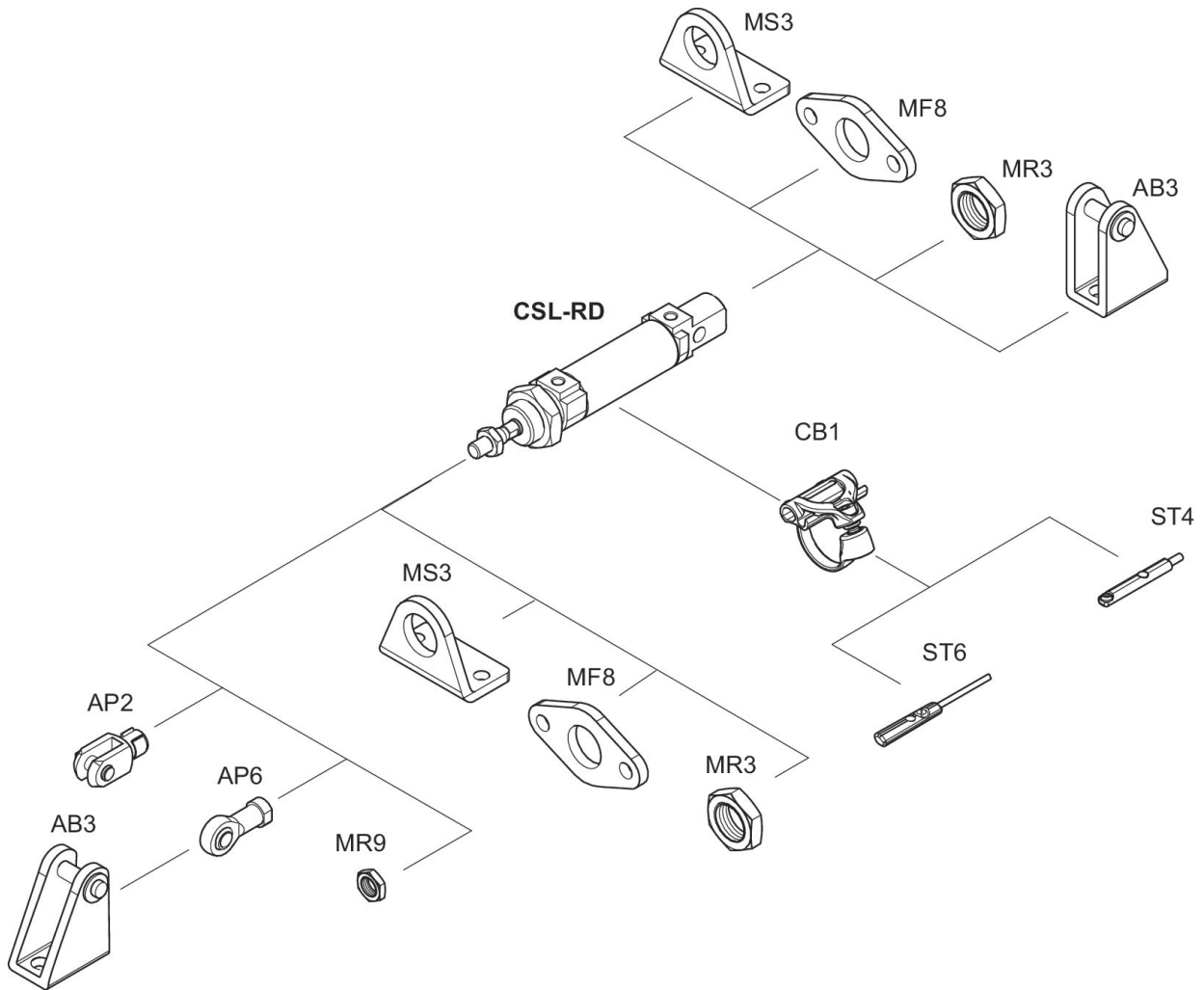

NOTE: This overview drawing is only for orientation to indicate where the various accessory parts can be fastened to the cylinder. The illustration has been simplified for this purpose. It is thus not possible to derive the dimensions from this overview.