

3/2-directional valve, Dual valve, IS12-PD series, size 1

2024-03-18

R422003191

Series IS12-PM, size 1

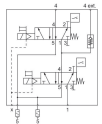
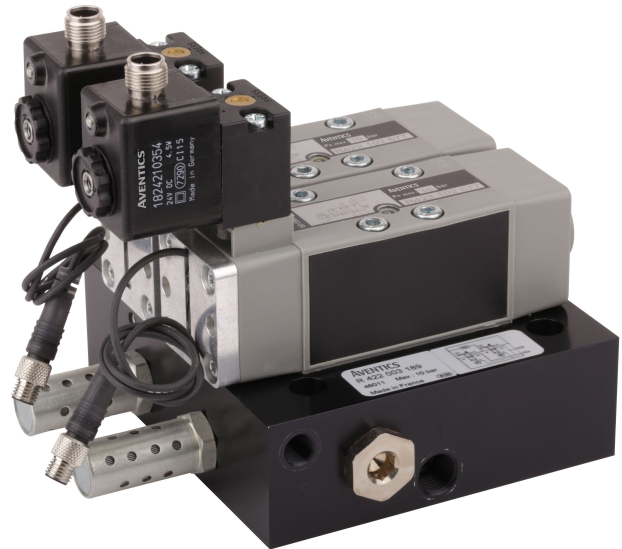

Technical data

Industry	Industrial
Activation	Electrically
Compressed air connection output	G 1/4
Min. working pressure	1 bar
Max. working pressure	10 bar
Operational voltage	24 V DC
Operational voltage DC	24 V
Voltage tolerance DC	-10% / +10%
Manual override	without detent
Electrical connection type	Plug
Electrical connection size	EN 175301-803, form A
Actuating control	Single Solenoid
Sealing principle	Soft seal
Pilot	External
Standards	ISO 5599-1, ISO 13849-1
Pilot valve width	30 mm
Valve type	Spool valve
Blocking principle	Double base plate principle
Connection type	Plate connection

3/2-directional valve, Dual valve, IS12-PD series, size 1

2024-03-18

R422003191

Return	With spring return
Compressed air connection input	G 1/4
Compressed air connection, exhaust	G 1/4
Power consumption DC	4.4 W
Min. control pressure	3.5 bar
Max. control pressure	10 bar
Min. ambient temperature	0 °C
Max. ambient temperature	50 °C
Min. medium temperature	0 °C
Max. medium temperature	50 °C
Medium	Compressed air
Max. particle size	5 µm
Min. oil content of compressed air	0 mg/m ³
Max. oil content of compressed air	0.01 mg/m ³
Nominal flow Qn 1 to 2	800 l/min
Nominal flow Qn 4 to 5	1050 l/min
Nominal flow Qn 4ext to 5	700 l/min
Protection class with connection	IP65
Compatibility index	15
Duty cycle	100 %
Typ. switch-on time	20 ms
Typ. switch-off time	40 ms
Switch-on time	18 ms
Switch-off time	40 ms
Type sensor	electronic PNP, with LED
Electrical connection for sensor	Plug
Sensor port size	M8
Sensor number of poles	3-pin
Voltage drop sensor U at I _{max}	≤ 2,5 V
Vibration resistance sensor	10 - 55 Hz, 1 mm
Shock resistance sensor	30 g / 11 ms
Protection class sensor acc. to DIN EN 61140	Class III
Sensor	with knurled screw
Cable length sensor	0.3 m
Weight	2.4 kg
Housing material	Polyamide Aluminum
Seal material	Acrylonitrile butadiene rubber
Part No.	R422003191

3/2-directional valve, Dual valve, IS12-PD series, size 1

2024-03-18

R422003191

Technical information

When the valve is not actuated, the sensor sends a signal through pin 4 of the sensor connection.

When the valve is actuated, the sensor does not send a signal through pin 4 of the sensor connection.

The dual valve includes two IS12-PD-5/2-SR valves with position detection and fulfills the safety function "safe venting" and "protection against unexpected start-up". The dual valve permits use in categories 3 and 4 in accordance with ISO 13849-1 to achieve a control system performance level (PL) of up to PL = e.

On its own, the valve with position detection is not a safety component and is not a complete safety solution. It is designed to increase the diagnostic coverage (DC) of the control system.

For use in categories 3 to 4, additional requirements of DIN EN ISO 13849-1:2008-12 (e.g. CCF, DC, PLr, software, systematic errors) are taken into consideration by the user.

The min. control pressure must be adhered to, since otherwise faulty switching and valve failure may result!

The pressure dew point must be at least 15 °C less than ambient and medium temperature and may not exceed 3 °C.

The oil content of compressed air must remain constant during the life cycle.

Use only the approved oils from AVENTICS. Further information can be found in the "Technical information" document (available in <https://www.emerson.com/en-us/support>).

Dimensions

3/2-directional valve, Dual valve, IS12-PD series, size 1

2024-03-18

R422003191
Fig. 1

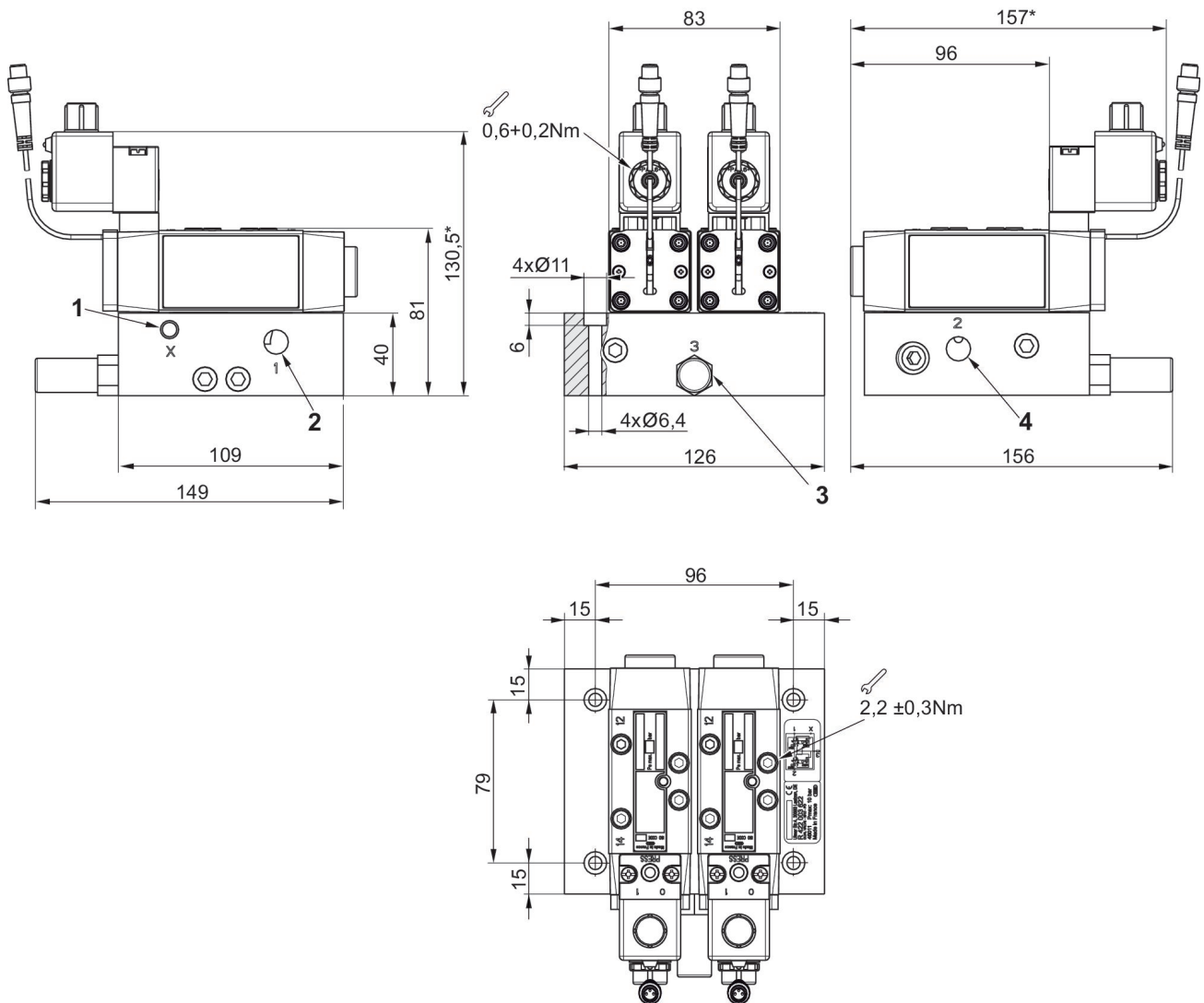

*) max.

- 1) External pilot pressure G1/8
- 2) Input pressure G1/4
- 3) Exhaust G 1/4
- 4) Output pressure G1/4

Dimensions Fig. 2

3/2-directional valve, Dual valve, IS12-PD series, size 1

2024-03-18

R422003191
Dual valve with integrated non-return valve

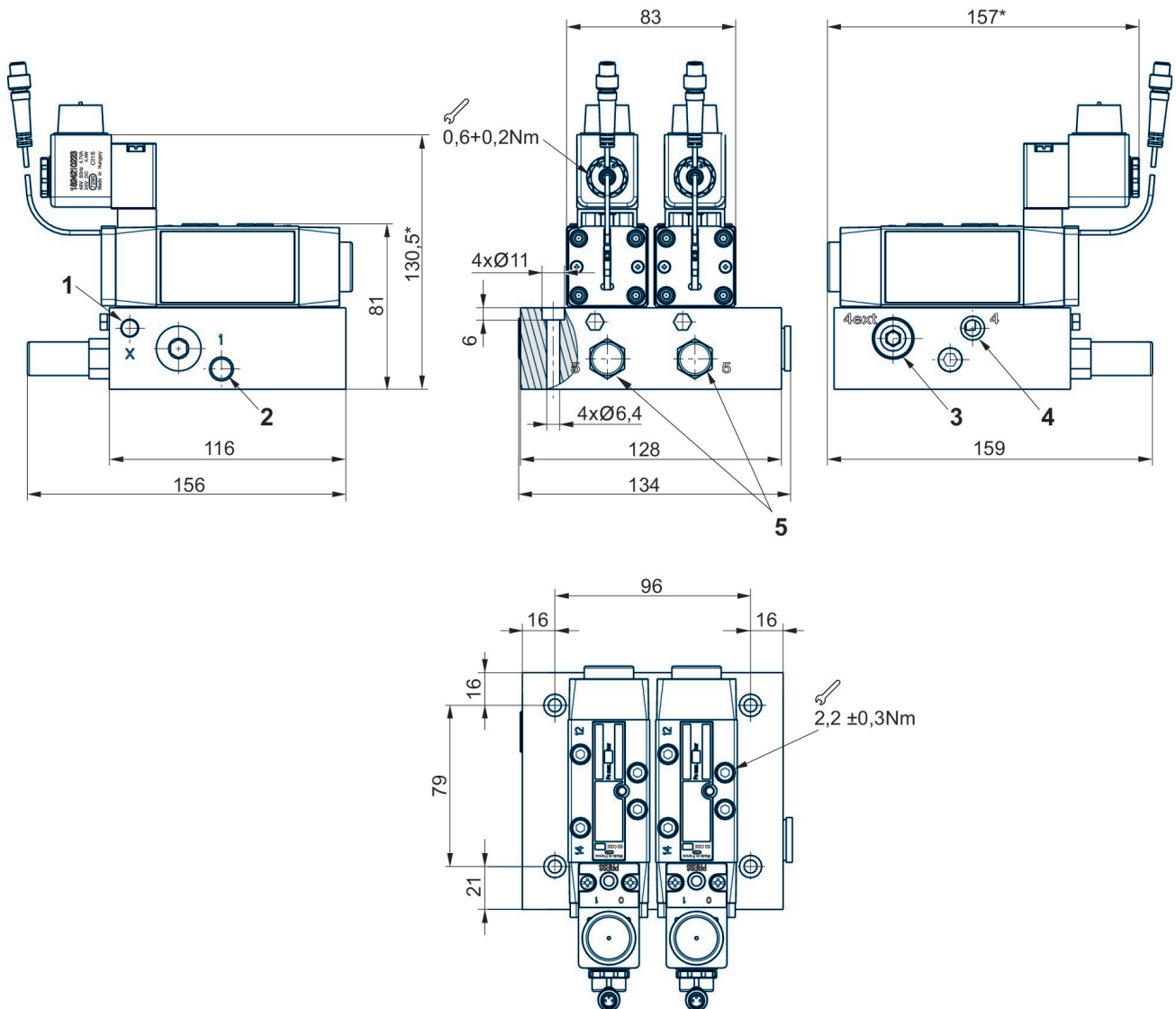

*) max.

- 1) External pilot pressure G1/8
- 2) Input pressure G1/4
- 3) Exhaust in with non-return valve G1/4
- 4) Output pressure G1/4
- 5) Exhaust G 1/4