

## AVENTICS Series EBS Ejectors

The AVENTICS Series EBS ejectors are the convincing and talented multi-taskers within the AVENTICS ejector Series. Parallel to the main advantages of this ejector Series, these ejectors offer additional benefits due to their enormous versatility.

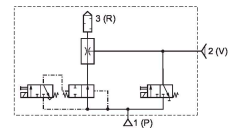
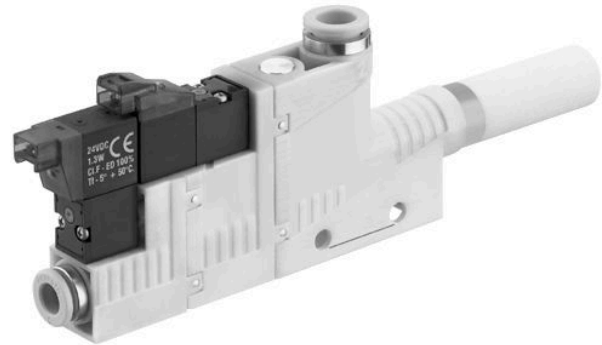

## Technical data

Industry	Industrial
Activation	Electrically
Note	push-in fitting
Type	Ejector
Version	electrical control, T-design
with silencer	with silencer
Nozzle Ø	1 mm
Min. working pressure	3 bar
Max. working pressure	6 bar
Min. ambient temperature	0 °C
Max. ambient temperature	50 °C
Min. medium temperature	0 °C
Max. medium temperature	50 °C
Medium	Compressed air
Min. oil content of compressed air	0 mg/m <sup>3</sup>
Max. oil content of compressed air	1 mg/m <sup>3</sup>
Max. particle size	5 µm
Compressed air connection	Ø 6
Vacuum connection+	Ø 8

# Ejector, Series EBS

2024-02-20

R412007463

---

Max. suction capacity	35 l/min
Air consumption at p.opt.	48 l/min
Max. vacuum level at p.opt	86 %
Sound pressure level intake effect	59 dB
Sound pressure level intake effect release valve	65 dB release valve
Display	LED
Protection class according to EN 60529:2000, without electrical connector	IP40
Operational voltage DC	24 V
Voltage tolerance DC	- 5% / +10%
Power consumption solenoid valve	1.3 W
Weight	0.065 kg
Housing material	Polyamide fiber-glass reinforced
Seal material	Acrylonitrile butadiene rubber
Nozzle material	Aluminum
Material release ring	Polyamide
Silencer material	Polyethylene
Part No.	R412007463

## Technical information

Note: All data refers to an ambient pressure of  $[[1,013]]$  bar] and an ambient temperature of  $[[20]]^{\circ}\text{C}$ .  
The pressure dew point must be at least  $15^{\circ}\text{C}$  less than ambient and medium temperature and may not exceed  $3^{\circ}\text{C}$ .

# Ejector, Series EBS

2024-02-20

R412007463

Fig. 1

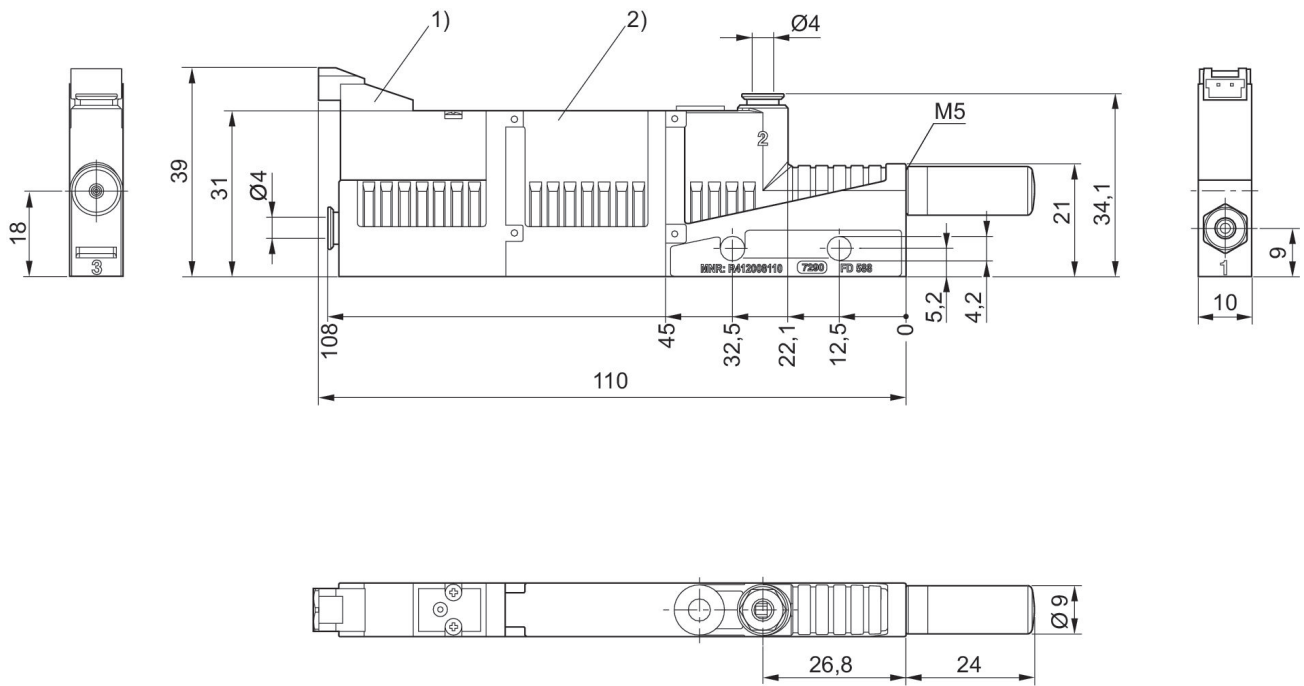

- 1) Solenoid valve for vacuum ON/OFF
- 2) Release valve from memory

Fig. 2

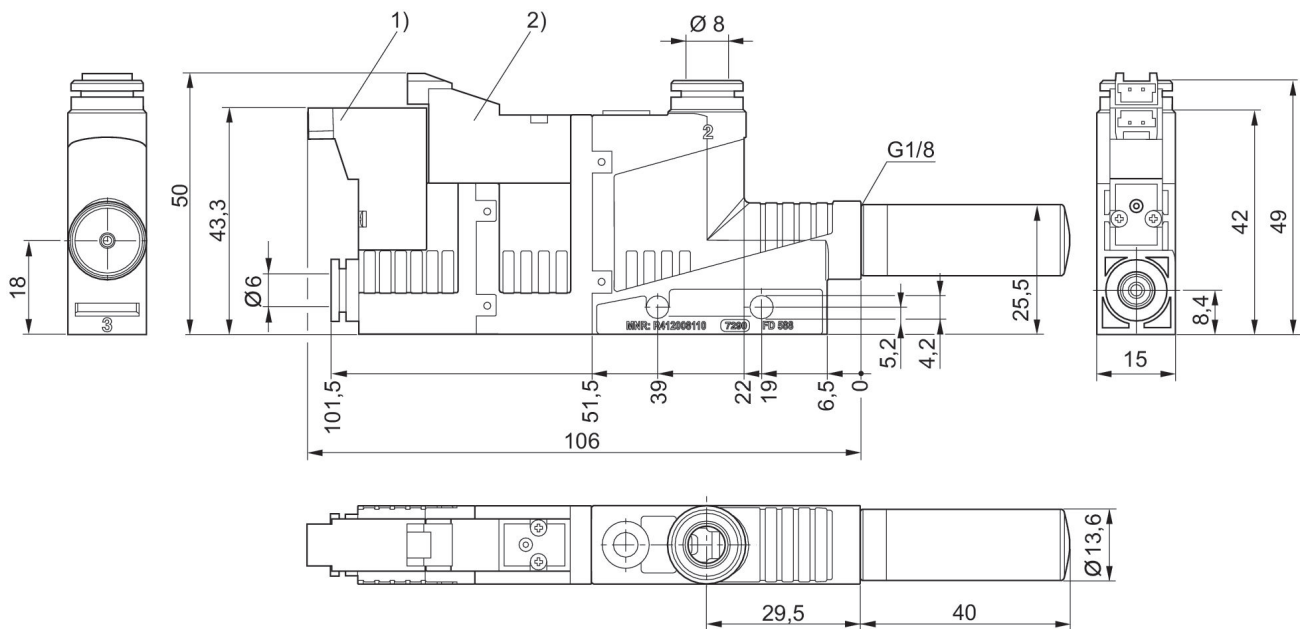

- 1) Solenoid valve for vacuum ON/OFF
- 2) Solenoid valve for release pulse

Fig. 3

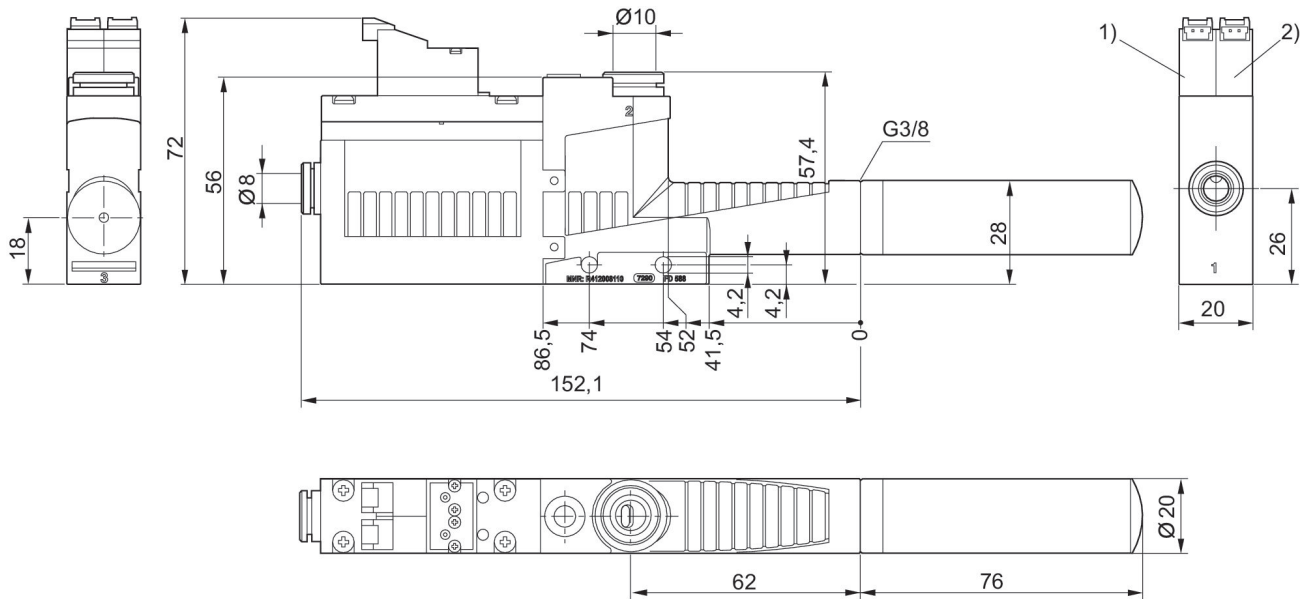

- 1) Solenoid valve for vacuum ON/OFF
- 2) Solenoid valve for release pulse

## Vacuum $p_2$ depending on working pressure $p_1$

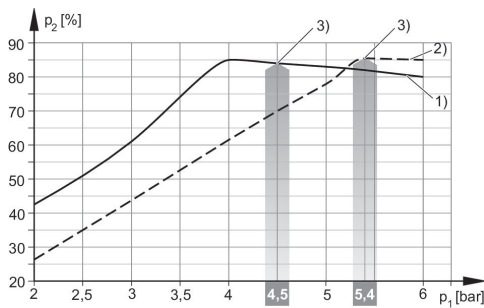

- 1) =  $\text{Ø}$  nozzle 0.5 mm 2) =  $\text{Ø}$  nozzle 0.7 mm
- 3) optimum working pressure

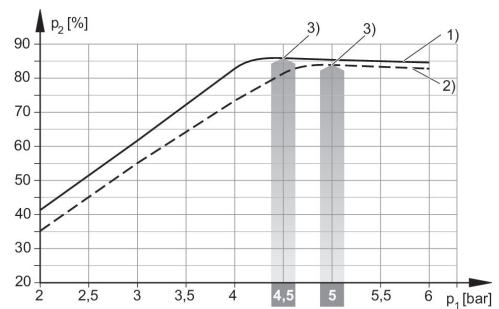

- 1) =  $\text{Ø}$  nozzle 1.0 mm 2) =  $\text{Ø}$  nozzle 1.5 mm
- 3) optimum working pressure

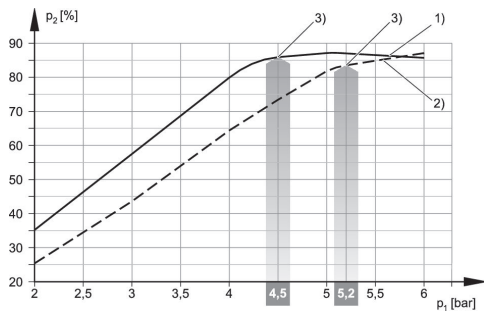

1) = Ø nozzle 2.0 mm 2) = Ø nozzle 2.5 mm  
3) optimum working pressure

## Suction capacity $q_s$ depending on working pressure $p_1$

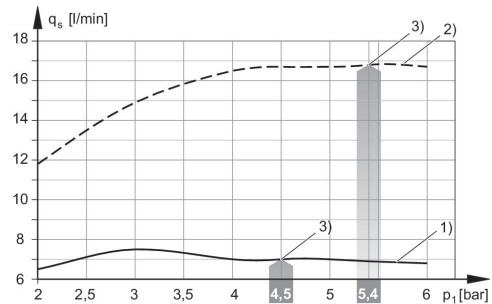

1) = Ø nozzle 0.5 mm 2) = Ø nozzle 0.7 mm  
3) optimum working pressure

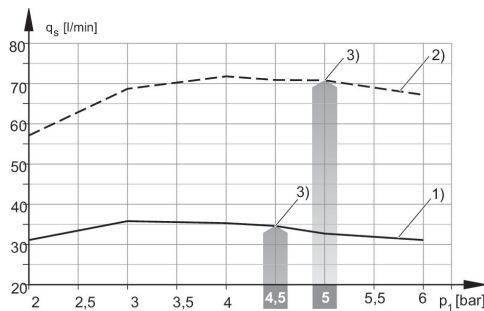

1) = Ø nozzle 1.0 mm 2) = Ø nozzle 1.5 mm  
3) optimum working pressure

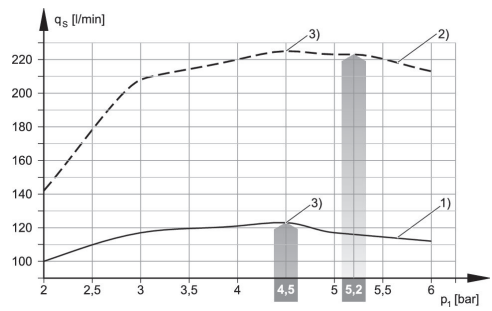

1) = Ø nozzle 2.0 mm 2) = Ø nozzle 2.5 mm  
3) optimum working pressure

## Evacuation time $t_E$ depending on vacuum $p_2$ for 1 l volume (with optimal operating pressure $p_{1opt}$ )

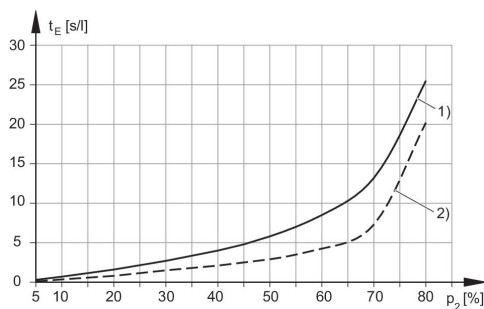

1) = Ø nozzle 0.5 mm 2) = Ø nozzle 0.7 mm

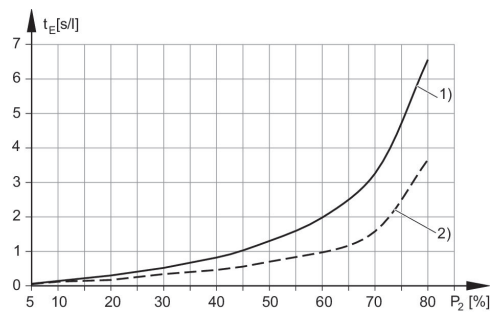

1) = Ø nozzle 1.0 mm 2) = Ø nozzle 1.5 mm

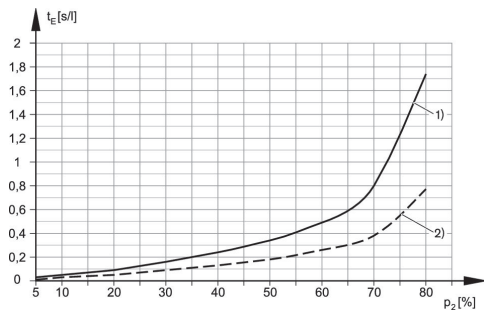

1) =  $\varnothing$  nozzle 2.0 mm 2) =  $\varnothing$  nozzle 2.5 mm

## Air consumption $q_v$ depending on working pressure $p_1$

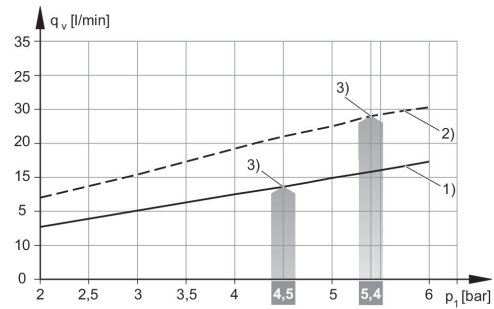

1) =  $\varnothing$  nozzle 0.5 mm 2) =  $\varnothing$  nozzle 0.7 mm  
3) optimum working pressure

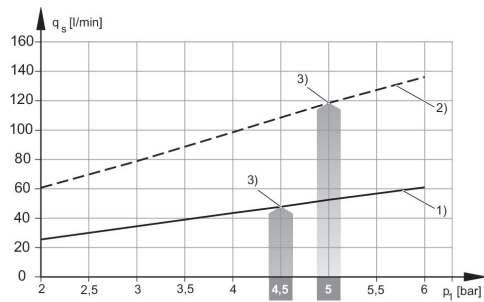

1) =  $\varnothing$  nozzle 1.0 mm 2) =  $\varnothing$  nozzle 1.5 mm  
3) optimum working pressure

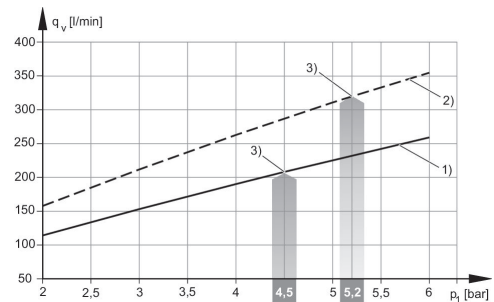

1) =  $\varnothing$  nozzle 2.0 mm 2) =  $\varnothing$  nozzle 2.5 mm  
3) optimum working pressure