

## AVENTICS Series EMS Ejectors

The AVENTICS Series EMS features an extremely compact design that can be installed flexibly near the suction points for quick response time and offers high energy efficiency due to its sophisticated nozzle geometry. With the Venturi nozzles connected in Series, they offer an enormous suction capacity with maximum efficiency, covering a wide range of vacuum applications. Depending on the properties of the workpiece being moved, the ejectors are available in two basic versions and three performance categories. The Series EMS multistage injectors are ideal for applications requiring a high flow with a low vacuum.

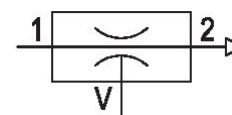

## Technical data

Industry	Industrial
Activation	Pneumatically
with silencer	with silencer
Min. working pressure	2 bar
Max. working pressure	6 bar
Working pressure p.opt.	4.5 bar
Min. ambient temperature	0 °C
Max. ambient temperature	60 °C
Min. medium temperature	0 °C
Max. medium temperature	60 °C
Medium	Compressed air
Min. oil content of compressed air	0 mg/m <sup>3</sup>
Max. oil content of compressed air	1 mg/m <sup>3</sup>
Max. particle size	5 µm
Max. suction capacity	252 l/min
Air consumption at p.opt.	88 l/min
Max. vacuum level at p.opt.	60 %
Sound pressure level intake effect	56 dB
Sound pressure level intake effect	67 dB

# Multistage ejector, Series EMS

Series EMS

R412026097

2024-03-07

Weight	0.8 kg
Housing material	Polyamide
Seal material	Acrylonitrile butadiene rubber
Nozzle material	Aluminum
Silencer material	Polyurethane
Part No.	R412026097

## Technical information

Note: All data refers to an ambient pressure of  $[[1,013]$  bar] and an ambient temperature of  $[[20]^{\circ}\text{C}]$ .  
The pressure dew point must be at least  $15^{\circ}\text{C}$  less than ambient and medium temperature and may not exceed  $3^{\circ}\text{C}$ .

The oil content of compressed air must remain constant during the life cycle.

## Dimensions

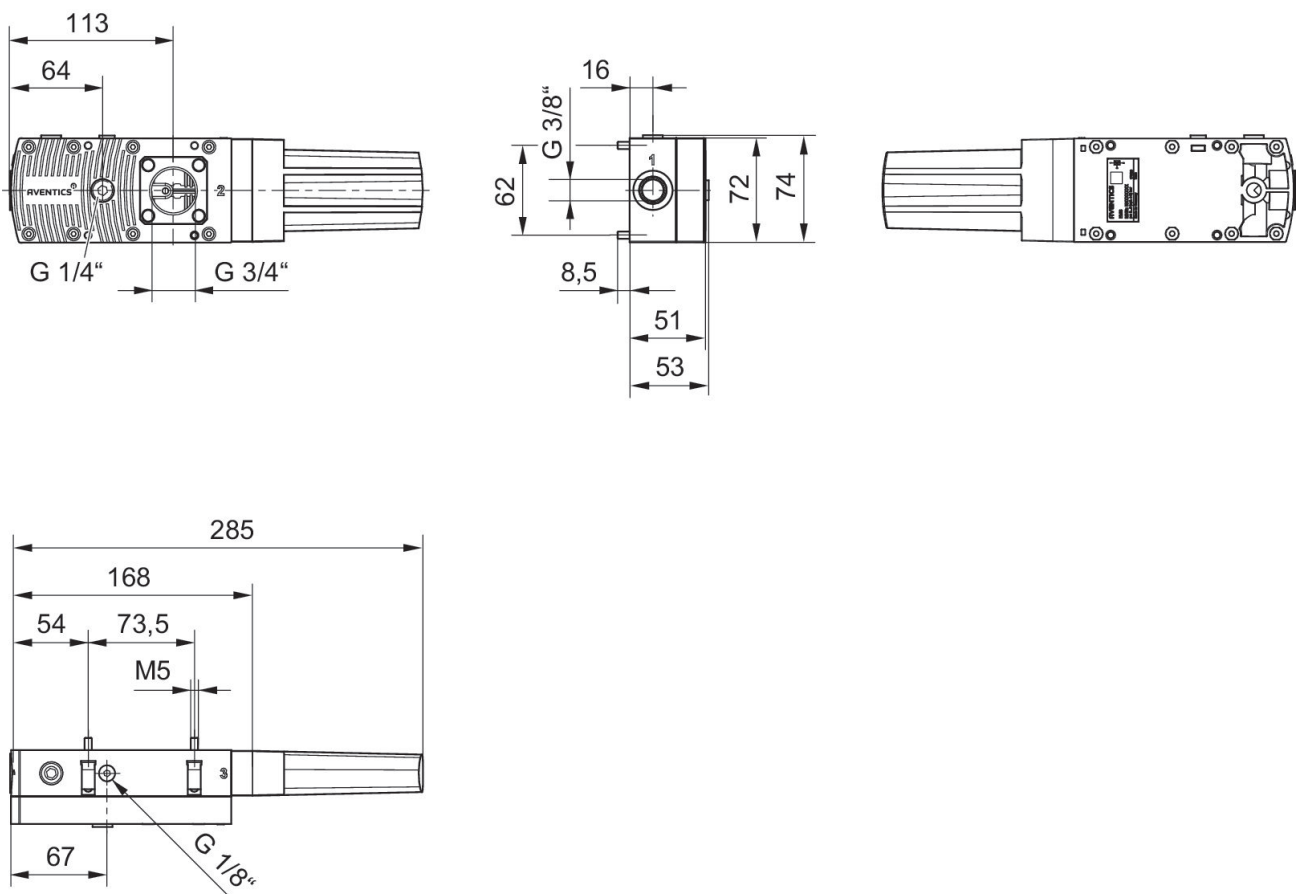

Air consumption  $q_v$  depending on working pressure  $p_1$

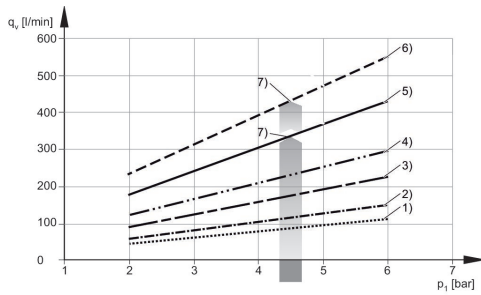

- 1) EMS-PT-25-HF
- 2) EMS-PT-25-HV
- 3) EMS-PT-50-HF
- 4) EMS-PT-50-HV
- 5) EMS-PT-100-HF
- 6) EMS-PT-100-HV
- 7) optimum working pressure

Evacuation time  $t_E$  depending on vacuum  $p_2$  for 1 l volume (with optimal operating pressure  $p_{1opt}$ )

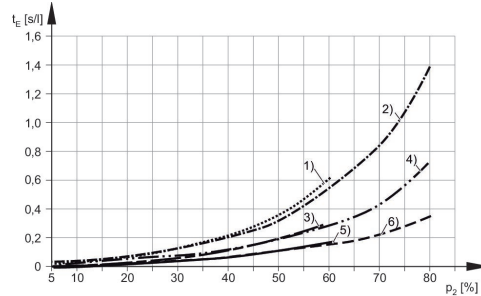

- 1) EMS-PT-25-HF
- 2) EMS-PT-25-HV
- 3) EMS-PT-50-HF
- 4) EMS-PT-50-HV
- 5) EMS-PT-100-HF
- 6) EMS-PT-100-HV

Suction capacity  $q_s$  depending on working pressure  $p_1$

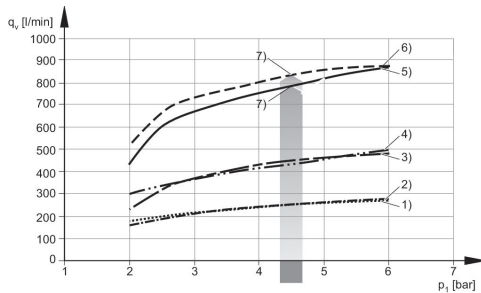

- 1) EMS-PT-25-HV
- 2) EMS-PT-25-HF
- 3) EMS-PT-50-HF
- 4) EMS-PT-50-HV
- 5) EMS-PT-100-HV
- 6) EMS-PT-100-HF
- 7) optimum working pressure

Vacuum  $p_2$  depending on working pressure  $p_1$

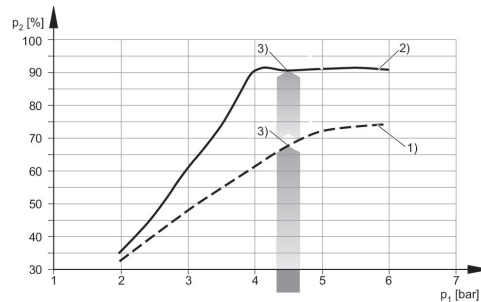

- 1) EMS-PT-25/50-HF
- 2) EMS-PT-25/50-HV
- 3) optimum working pressure

## Noise level, suctioned

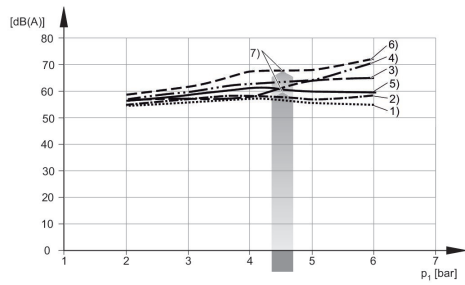

- 1) EMS-PT-25-HF
- 2) EMS-PT-25-HV
- 3) EMS-PT-50-HF
- 4) EMS-PT-50-HV
- 5) EMS-PT-100-HF
- 6) EMS-PT-100-HV
- 7) optimum working pressure

## Noise level at free suctioning

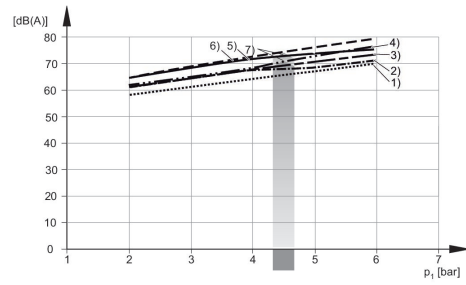

- 1) EMS-PT-25-HF
- 2) EMS-PT-25-HV
- 3) EMS-PT-50-HF
- 4) EMS-PT-50-HV
- 5) EMS-PT-100-HF
- 6) EMS-PT-100-HV
- 7) optimum working pressure

## Circuit diagram

EMS-PT

