

## Series EV12

The AVENTICS EV18 high flow proportional pressure valves with digital control are highly efficient and ideal for pressure regulation requirements. It offers a small footprint and easy-to-use modular design. These high flow pressure regulators can be directly integrated on the Series AS air preparation unit, increasing efficiency with one compact and complete IIoT solution from one supplier, or they can be used as a standalone proportional pressure regulator with high flow capabilities.

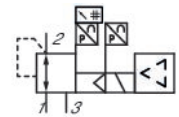

## Technical data

|                          |  |
|--------------------------|--|
| Type                     | Pressure supply, right   |
| Control                  | Display: display   |
| Function                 | Externally piloted   |
| Air supply               | Pressure-holding, output 10V constant to supply a set point potentiometer. |
| Min. regulation range    | right  |
| Max. regulation range    | 0 bar  |
| Min. working pressure    | 10 bar   |
| Max. working pressure    | 0 bar  |
| Hysteresis               | 10 bar   |
| Nominal flow Qn          | 0,12 bar   |
| Min. ambient temperature | 16500 l/min  |
| Max. ambient temperature | 0 °C   |
| Min. medium temperature  | 50 °C  |
| Max. medium temperature  | 0 °C   |
| Operational voltage DC   | 50 °C  |
| Max. current consumption | 24 V   |
| Permissible ripple       | 220 mA   |
| Max. particle size       | 5%   |
|                          | 50 µm  |

# E/P pressure regulator, Series EV18

2024-02-20

R414011417

---

|                                       |                     |
|---------------------------------------|---------------------|
| Min. oil content of compressed air    | 0 mg/m <sup>3</sup> |
| Max. oil content of compressed air    | 5 mg/m <sup>3</sup> |
| Frame size                            | AS5                 |
| Type                                  | Poppet valve        |
| Compressed air connection input       | G 3/4               |
| Compressed air connection output      | G 3/4               |
| Electrical connection size            | M12                 |
| Electrical connection number of poles | 5-pin               |
| Electrical connection coding          | A-coded             |
| Actual output value                   | 0 ... 10 V          |
| Nominal input value                   | 0 ... 10 V          |
| Industry                              | Industrial          |
| Weight                                | 2.15 kg             |

## Material

|                     |                          |
|---------------------|--------------------------|
| Housing material    | Polyamide                |
| Seal material       | Nitrile butadiene rubber |
| Material base plate | Aluminum                 |
| Part No.            | R414011417               |

## Technical information

Power outage: maintain pressure

The min. control pressure must be adhered to, since otherwise faulty switching and valve failure may result!

The pressure dew point must be at least 15 °C less than ambient and medium temperature and may not exceed 3 °C.

The oil content of compressed air must remain constant during the life cycle.

Use only the approved oils from AVENTICS. Further information can be found in the "Technical information" document (available in <https://www.emerson.com/en-us/support>).

## Dimensions

# E/P pressure regulator, Series EV18

2024-02-20

R414011417

Pressure supply, right

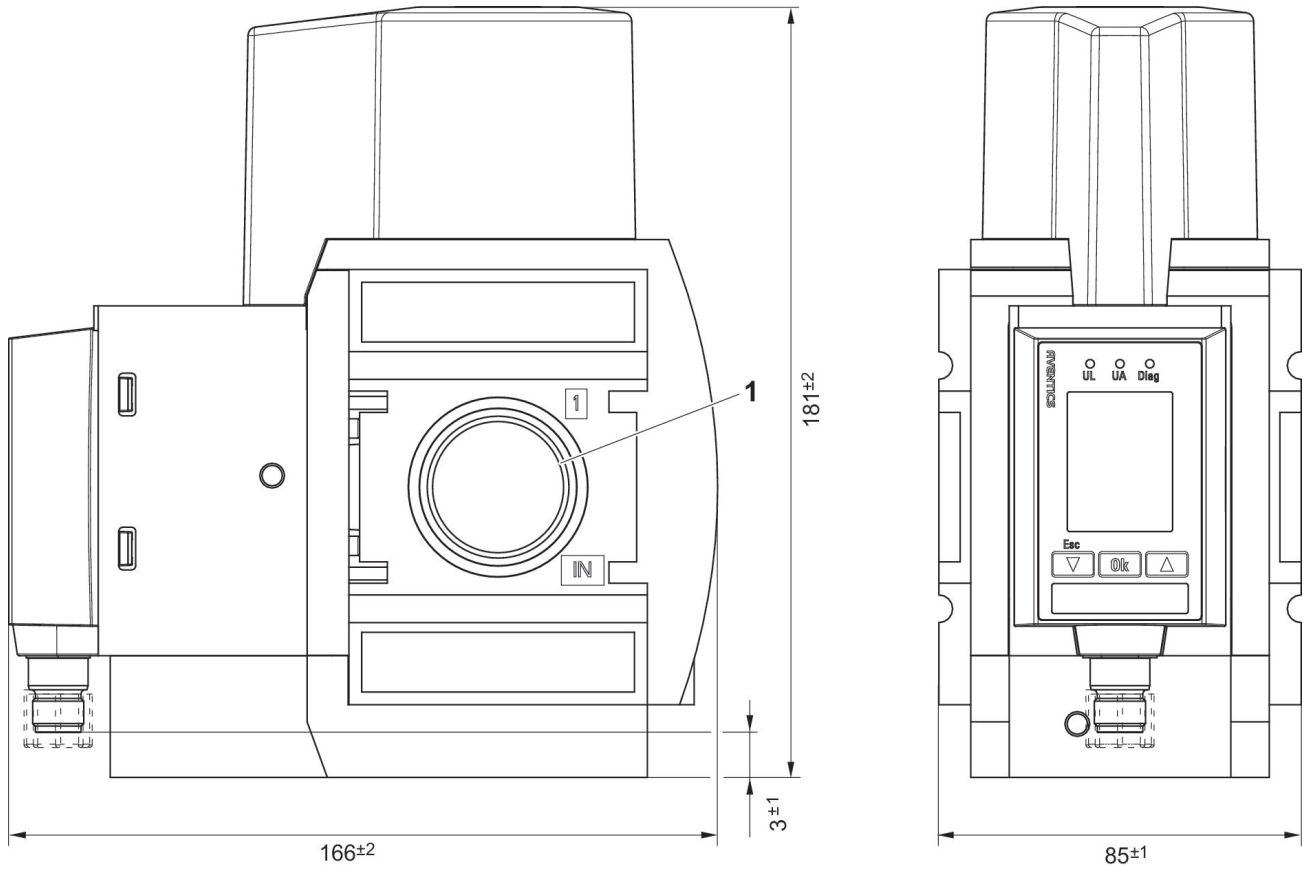

1) Connection thread

# E/P pressure regulator, Series EV18

2024-02-20

R414011417

Pressure supply, right

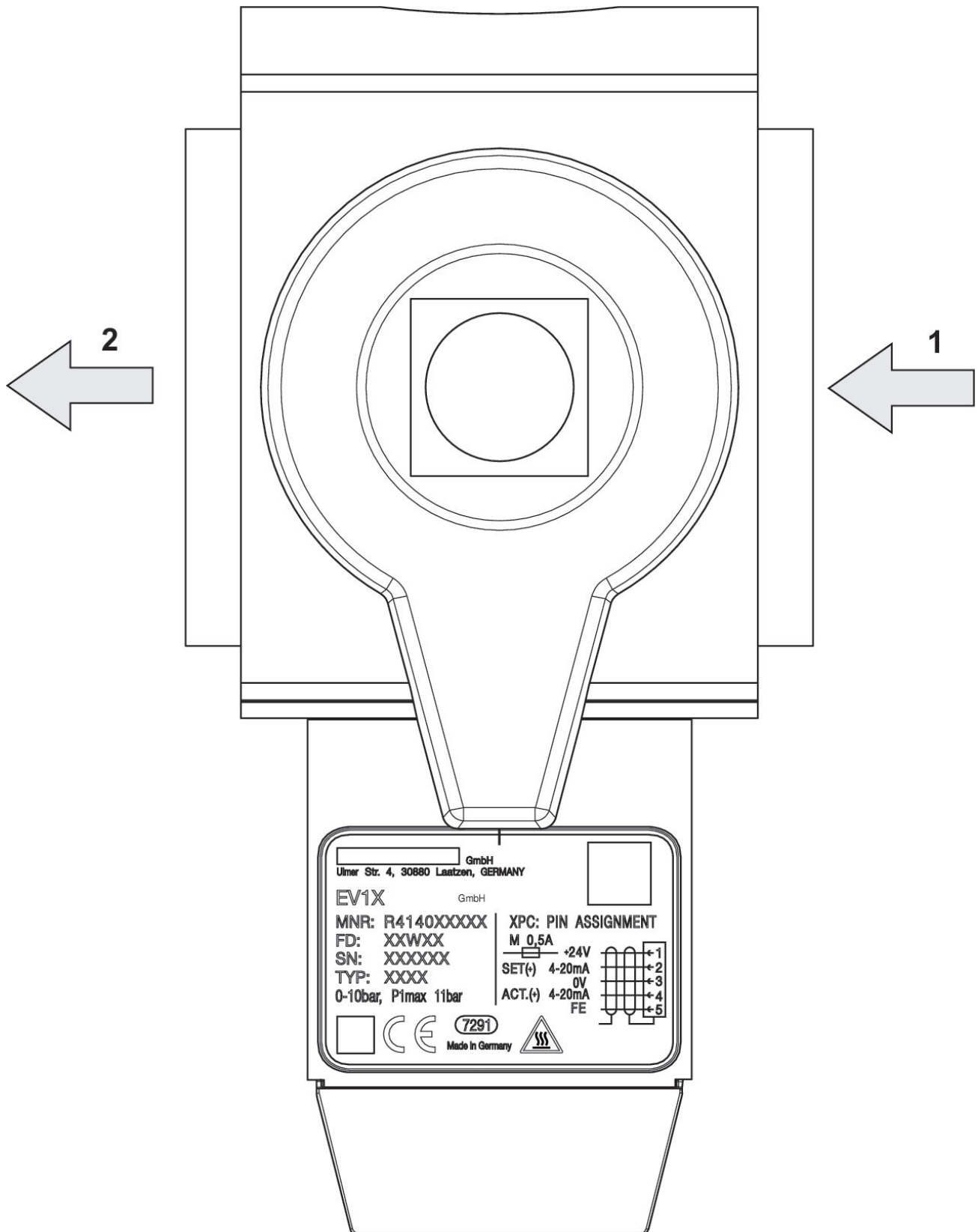

R414011417

## Flow characteristic curve

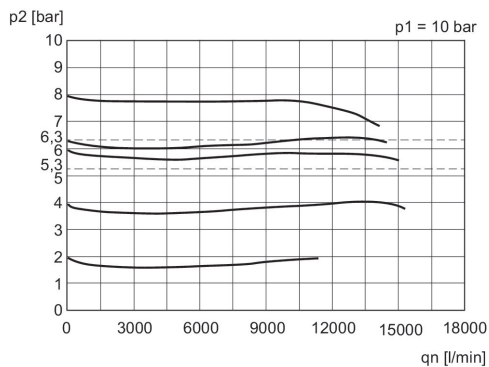

p1 = Working pressure p2 = Secondary pressure qn = Nominal flow

## Characteristic curve and plug assignment for IO-Link version

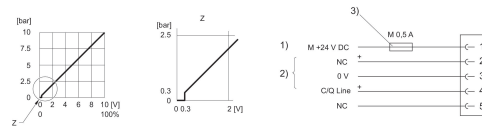

- 1) power supply
- 2) C/Q Line (pin 4) Not connected (NC) (pin 2) are related to 0 V (pin 3).
- 3) The power supply must be protected by an external M 0.5 A fuse. Connect the plug via a shielded cable to ensure EMC.

## Characteristic and pin assignment for voltage control with actual output value

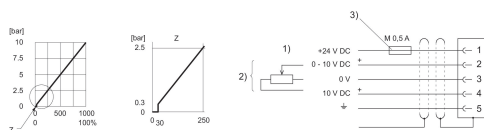

- 1) power supply
- 2) Actual value (pin 4) and nominal value (pin 2) are related to 0 V (pin 3). Nominal input value ( $R = 1 \text{ M}\Omega$ ), actual output value: min. load resistance  $> 10 \text{ K}\Omega$ . If the power supply is switched off, the nominal input value is high-ohmic.
- 3) The power supply must be protected by an external M 0.5 A fuse. Connect the plug via a shielded cable to ensure EMC.

## Characteristic and pin assignment for current control with actual output value

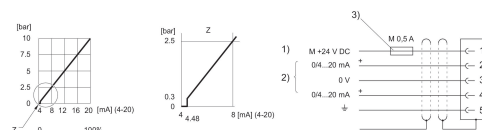

- 1) power supply
- 2) Actual value (pin 4) and nominal value (pin 2) are related to 0 V (pin 3). Nominal input value (ohmic load  $100 \Omega$ ), actual output value: external ohmic load  $< 300 \Omega$ . If the power supply is switched off, the nominal input value is high-ohmic.
- 3) The power supply must be protected by an external M 0.5 A fuse. Connect the plug via a shielded cable to ensure EMC.

## Functional diagram IO-Link

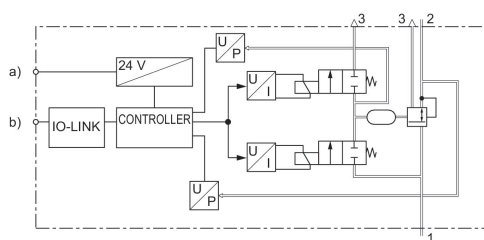

- a) Supply Voltage
- b) C/Q Line

## Functional diagram

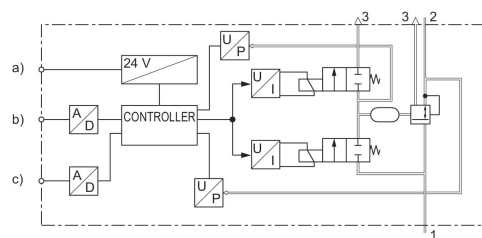

- a) Voltage supply
- b) Nominal value
- c) Actual output value

## Plug assignment

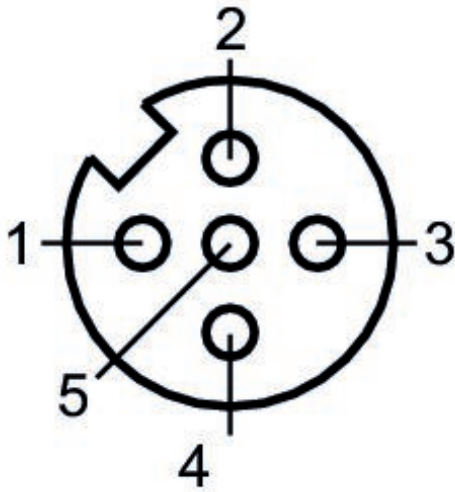

- 
- 1) 24 V DC
  - 2) Nominal input value
  - 3) GND
  - 4) Actual output value
  - 5) Ground