

Modular scraper system

The AVENTICS Modular scraper system and front lube unit offer more flexibility by implementing a different scraper model with the same cylinder if yours needs changing. They are available separately as spare parts with fully installed seals and bushings and can be exchanged at any time, quickly and easily, without removing the cylinder.



Technical data

Industry	Industrial
For series	CCL-IS
Piston Ø	80 mm 100 mm
Min. working pressure	1.5 bar
Max. working pressure	10 bar
Min. ambient temperature	-20 °C
Max. ambient temperature	80 °C
Medium	Compressed air
Min. oil content of compressed air	0 mg/m ³
Max. oil content of compressed air	5 mg/m ³

Material

Housing material	Aluminum, anodized
Piston rod seal	Polyester elastomer
Scraper	Polyester elastomer
Part No.	R412027887

Technical information

The pressure dew point must be at least 15 °C less than ambient and medium temperature and may not exceed 3 °C.

The oil content of compressed air must remain constant during the life cycle.

Use only the approved oils from AVENTICS. Further information can be found in the “Technical information” document (available in <https://www.emerson.com/en-us/support>).

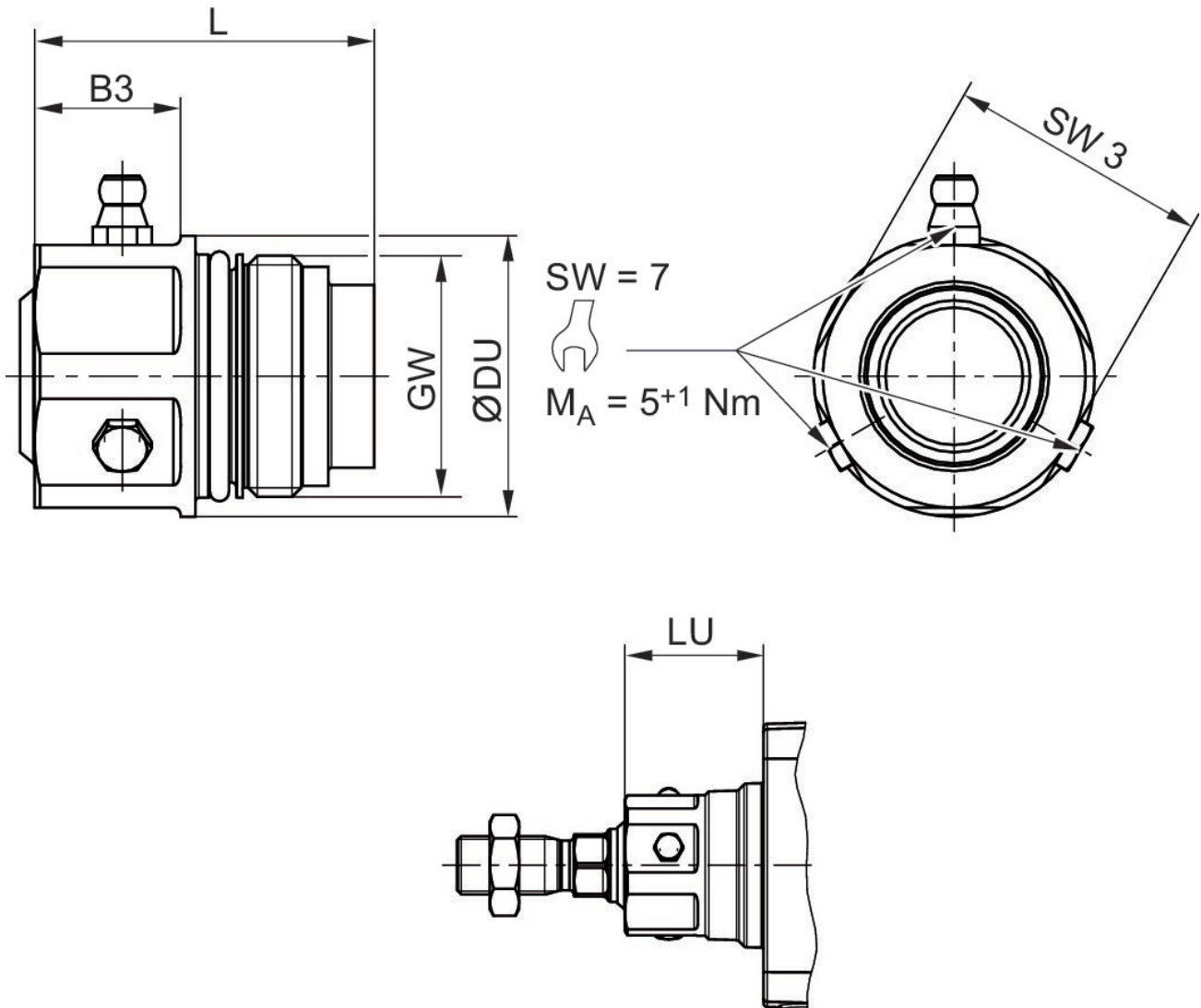

Piston Ø	Part No.	SW 3	MA [Nm]	GW	DU	L	B3	LU
32	R412027884	24	20	M22x1	27.5	36	6	29.25
40	R412027885	30	20	M26x1.5	34	41.1	20	31.25
50, 63	R412027886	36	30	M33x2	38.5	46.5	20	38
80, 100	R412027887	41	40	M40x2	44	57	21	46
125	R412027888	50	50	M50x2	57	69	23	58