

Pressure regulator, Series 646

G646ARH23NA00H0

General series information
AVENTICS Series 646 Pressure Regulator

- The Series 646 Railway Regulators and Filters are designed for the unique needs of the railway industry. The units meet railway regulations for Fire Safety (EN 45545: HL3), Shock & Vibration (EN 61373: Cat 1 Class B), and Corrosion Resistance (ISO 9227). The Series 646 Railway Regulators are robust, high flow products that are available with up to 10 bar (145 PSI) output pressure. They offer three adjustment methods including screw, t-handle, or lockable knob. The 646 Railway Filters provide exceptional filtration to ensure oil and particulates are removed from the compressed air system. Large high-flow elements ensure maximum element change out intervals with minimum system pressure drop and maximum air flow.

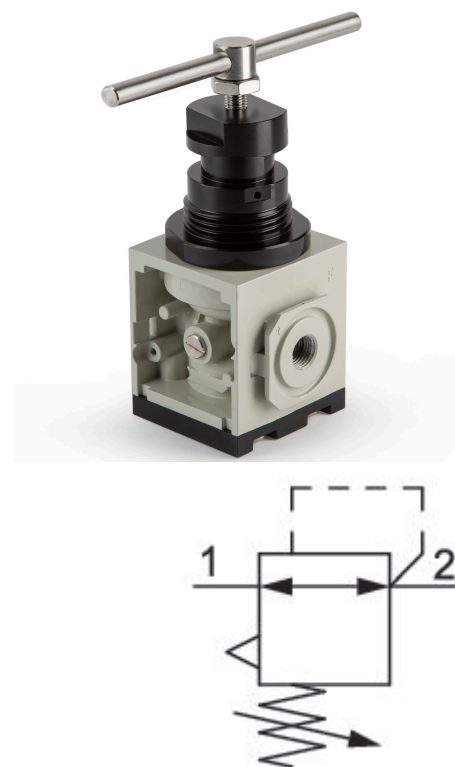

Technical data

Industry	Rail
Note	Complies with standards for railway applications
Function	high flow, inline ported
Parts	Pressure regulator
Adjustment options	T handle
Pressure gauge	Without pressure gauge, with transition plate
Mounting orientation	Any
Port	G 3/8
Compressed air connection standard	according to ISO 228-1
Nominal flow Q _n	6530 l/min
Regulation range min.	0.5 bar
Regulation range max.	10 bar
Working pressure min.	1 bar
Working pressure max	16 bar
Min. ambient temperature	-40 °C
Max. ambient temperature	70 °C
Medium	Compressed air

Min. medium temperature	-40 °C
Max. medium temperature	70 °C
Weight	0.272 kg

Material

Housing material	Aluminum
Surface housing	anodized
Seal material	Acrylonitrile butadiene rubber
Part No.	G646ARH23NA00H0

Technical information

Order pressure gauge separately

The min. control pressure must be adhered to, since otherwise faulty switching and valve failure may result!

The pressure dew point must be at least 15 °C less than ambient and medium temperature and may not exceed 3 °C.

The oil content of compressed air must remain constant during the life cycle.

Dimensions in mm

