

- Two guide rods with high side load capacity and high precision
- Anti-twist protection for more safety
- Stroke adjustment possible (GPC-E and GPC-ST)
- Compact design
- Cost-effective solution
- Direct combinations with Easy-2-Combine possible

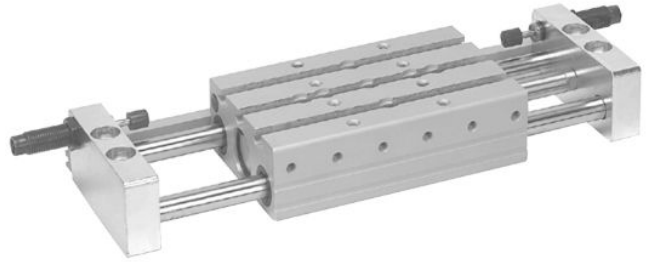

AVENTICS Series SH

The AVENTICS Series GPC is distinguished by high side load capacity and torsion protection. The drive and guide rods are robust and precise with high torque and transverse force absorption.



Technical data

Industry	Industrial
Type	Archive product: Do not use in new constructions!
Piston Ø	12 mm
Piston rod Ø	6 mm
Stroke	150 mm
Functional principle	Double-acting
Bearing type	ball bearing
Magnetic piston	with magnetic piston
Cushioning	hydraulic
Cushioning	non-adjustable
Min. working pressure	2 bar
Max. working pressure	8 bar
Min. ambient temperature	0 °C
Min. ambient temperature	32 °F
Max. ambient temperature	65 °C
Max. ambient temperature	149 °F
Min. oil content of compressed air	0 mg/m ³
Max. oil content of compressed air	5 mg/m ³
Easy2Combine	Easy2Combine capable with connection kit
Port	M5
Retracting piston force	53 N
Retracting piston force	11.91 lbf
Extracting piston force	71 N
Extracting piston force	15.96 lbf
Max. speed	0.5 m/s

Impact energy	0.1 J
Max. play with locked end position	0.08 mm
Medium	Compressed air
Max. particle size	50 µm
Pressure for determining piston forces	6,3 bar
Weight	1.07 kg

Material

Housing material	Aluminum
Surface housing	anodized
Seal material	Polyurethane
Material front plate	Steel, chrome-plated
Surface front plate	galvanized
Material guide rods	Steel, chrome-plated
Surface guide rods	hardened
Bearing material	Steel, chrome-plated
Surface bearing	hardened
Material piston rod	Stainless Steel
Part No.	R402000248

Technical information

The pressure dew point must be at least 15 °C less than ambient and medium temperature and may not exceed 3 °C.

The oil content of compressed air must remain constant during the life cycle.

Use only the approved oils from AVENTICS. Further information can be found in the “Technical information” document (available in <https://www.emerson.com/en-us/support>).

Dimensions

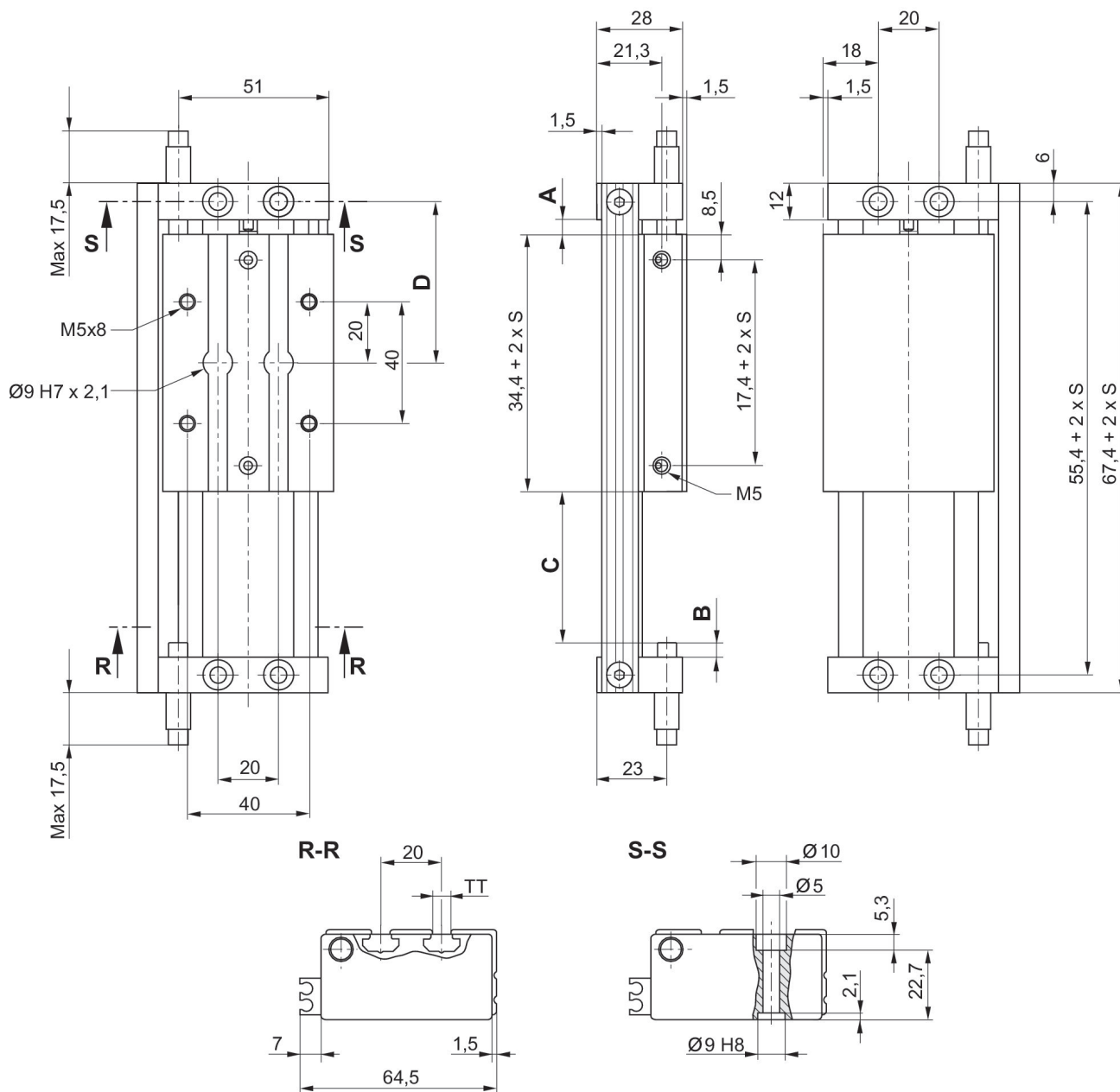

S = stroke

Piston \varnothing	A 1)	A 2)	B 1)	B 2)	C 1)	C 2)	D 1)	D 2)
12	4.7	24.7	4.2	24.2	S-40	S	25+0,5xS	48+0,5xS

1) Min. 2) Max. S = stroke

Permissible dynamic load m [kg]

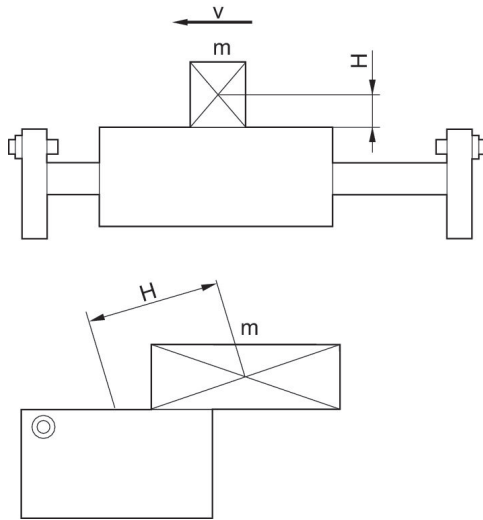

Maximum permissible force F and deflection D with static load

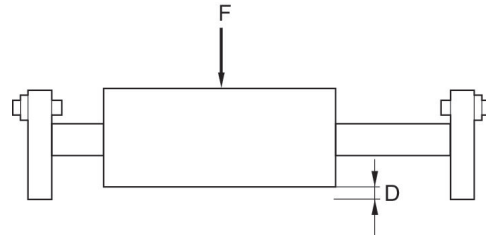

The load creates a high moment on the unit when reaching the end positions. It is therefore necessary not to exceed the limitations showed below. Following parameters must be considered: velocity, distance to center of mass and size of GPC-ST. When multiplying the mass m [kg] with the distance H [mm] the result must not exceed the values below. Example: A load of 2,3 kg shall be mounted with L 52 mm on a GPC-ST dia. 20 stroke 50. $m \times H$, $2,3 \times 52 = 120$. From the table below we can see that this is allowed for a velocity of 0,3 m/s.

Guide cylinders, Series GPC-ST

R402000248

Series GPC

2024-09-05

Overview drawing

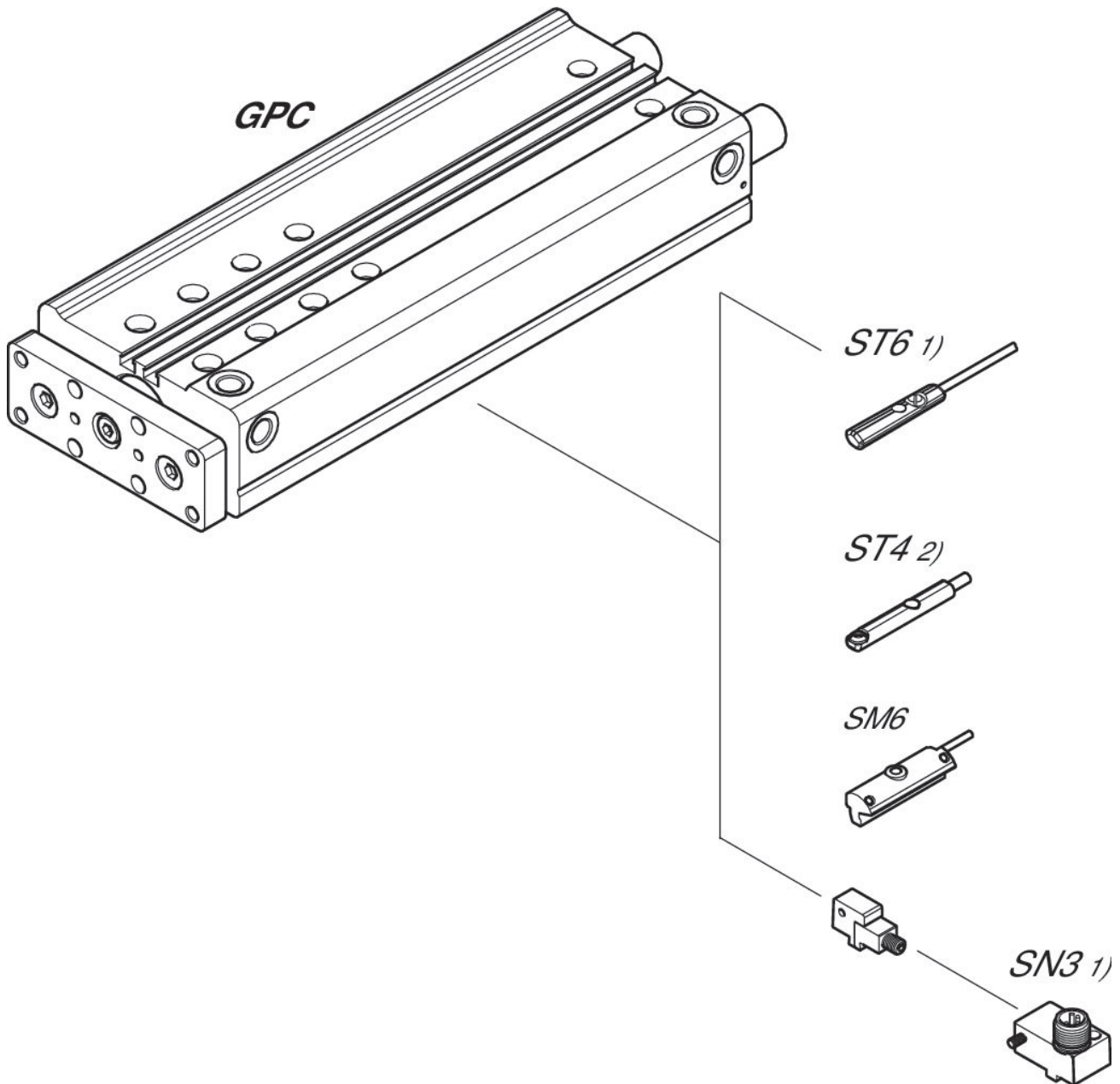

1) $\leq \text{Ø}12$ mm (GPC-BV, GPC-E, GPC-TL)

2) Only for $\text{Ø}10$ mm (GPC-BV) and all Ø (GPC-ST)

NOTE: This overview drawing is only for orientation to indicate where the various accessory parts can be fastened to the cylinder. The illustration has been simplified for this purpose. It is thus not possible to derive the dimensions from this overview.