

Series HF02-LG

The AVENTICS Series HF02-LG extends the product family of universal valve systems with a high flow rate of up to 1400 l/min.

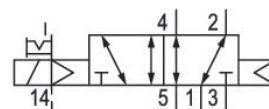
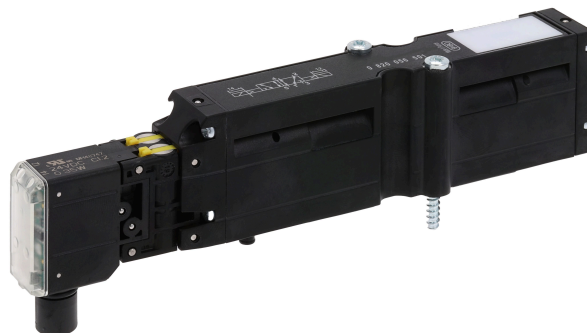

Technical data

Industry

Industrial

Activation

Electrically

Valve type

Spool valve, positive overlapping

Switching principle

5/2, double solenoid

Actuating control

Double Solenoid

Sealing principle

Soft seal

Connection type

Plate connection

Manual override

with detent

Pilot control exhaust

With collective pilot air exhaust

Nominal flow Q_n

1400 l/min

Flow conductance b

0.38

Flow conductance C

6.13 l/(s*bar)

Min. working pressure

-0.9 bar

Max. working pressure

10 bar

Min. control pressure

3 bar

Max. control pressure

10 bar

5/2-directional valve, Series HF02-LG

2024-04-03

0820056001

Protection class with connection	IP65
Protective circuit	Z-diode
Reverse polarity protection	Protected against polarity reversal
Operational voltage	24 V DC
Operational voltage DC	24 V
Voltage tolerance DC	-15% / +20%
Pilot	External Internal
Pilot valve width	16 mm
LED status display	Yellow
Power consumption DC	0.35 W
Duty cycle	100 %
Typ. switch-on time	19 ms
Typ. switch-off time	30 ms
Blocking principle	Single base plate principle
Can be assembled into blocks	Can be assembled into blocks
Certificates	UR (Underwriters Laboratories)
Min. ambient temperature	0 °C
Max. ambient temperature	50 °C
Min. medium temperature	0 °C
Max. medium temperature	50 °C
Medium	Compressed air
Min. oil content of compressed air	0 mg/m ³
Max. oil content of compressed air	5 mg/m ³
Max. particle size	5 µm
Mounting screws	cross recessed DIN EN ISO 4757-Z2
Mounting screw tightening torque	1.3 Nm
Weight	0.144 kg
Material	
Housing material	Polyamide
Seal material	Acrylonitrile butadiene rubber Hydrogenated acrylonitrile butadiene rubber
Part No.	0820056001

Technical information

The pilot type (external/internal) is not implemented in the valve, but in the end plate of the valve system.

The pilot valve is UL (Underwriters Laboratories) certified.

The min. control pressure must be adhered to, since otherwise faulty switching and valve failure may result!

The pressure dew point must be at least 15 °C less than ambient and medium temperature and may not exceed 3 °C.

The oil content of compressed air must remain constant during the life cycle.

Use only the approved oils from AVENTICS. Further information can be found in the "Technical information" document (available in <https://www.emerson.com/en-us/support>).

5/2-directional valve, Series HF02-LG

2024-04-03

0820056001

Dimensions

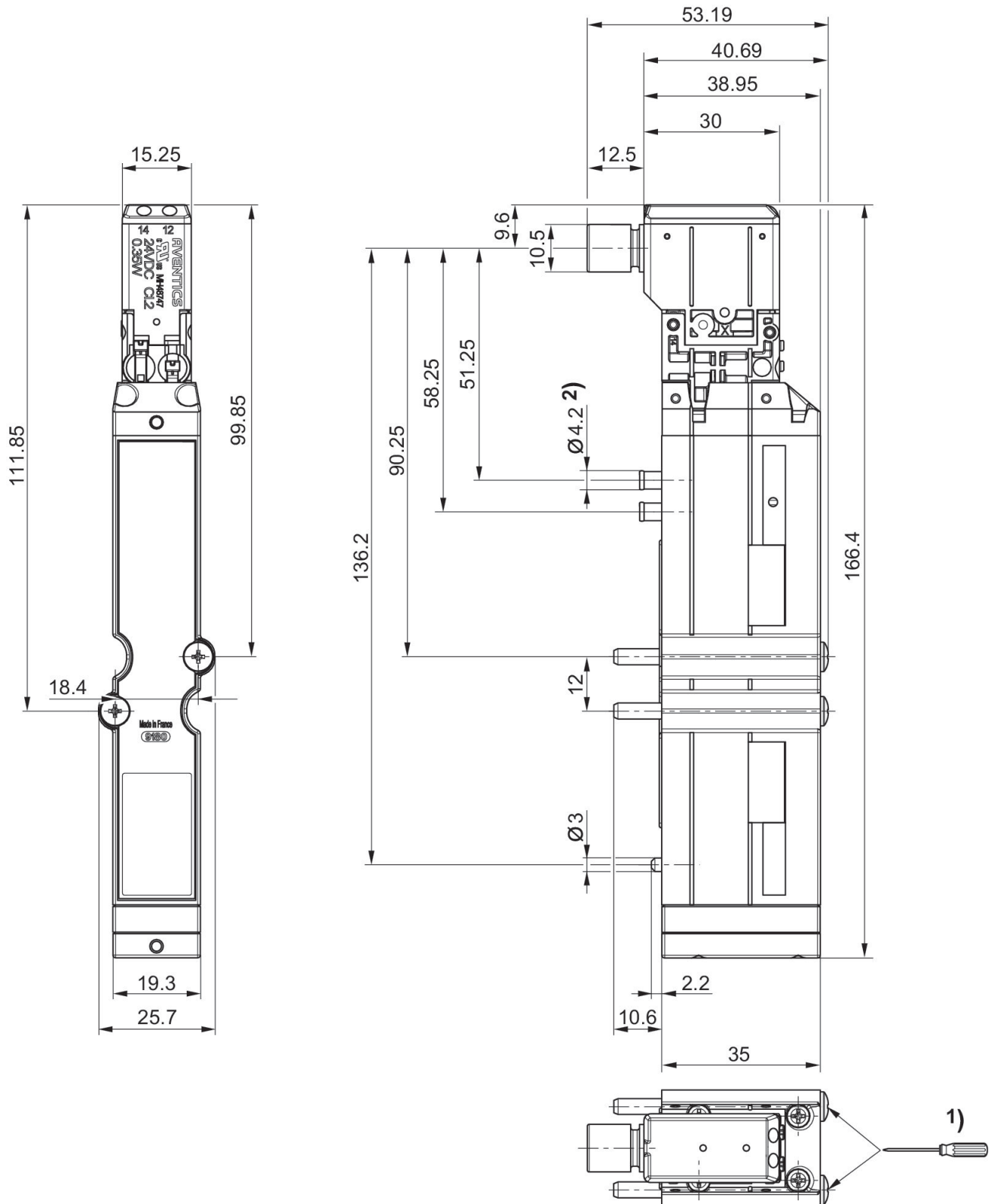

1) = 1.1 +0.2 Nm 800tr/min. max.