

- Ø 8 ... 32 mm
- Max. stroke: 400 mm
- corrosion-resistant
- Suitable for use in food processing

## AVENTICS Series ICM Mini cylinders

The AVENTICS Series ICM is a mini cylinder and cost-efficient solution for high corrosion resistance and reliability – even in harsh environments. The cylinder tube and piston rod are made of stainless steel, the cylinder covers are fashioned from a high-quality polymer.



## Technical data

|  |  |
|--|--|
| Industry                               | Industrial   |
| Standards                              | ISO 6432   |
| Piston Ø                               | 20 mm  |
| Stroke                                 | 60 mm  |
| Ports                                  | G 1/8  |
| Functional principle                   | Double-acting  |
| Cushioning                             | Elastic cushioning                                       |
| Magnetic piston                        | Piston with magnet                                       |
| Environmental requirements             | Industry standard<br>suitable for use in food processing |
| Piston rod thread - type               | External thread  |
| Piston rod thread                      | M8   |
| Piston rod                             | single   |
| Scraper                                | Standard Industry Scraper                                |
| Pressure for determining piston forces | 6,3 bar  |
| Retracting piston force                | 166 N  |
| Extracting piston force                | 198 N  |
| Min. ambient temperature               | -20 °C   |
| Max. ambient temperature               | 70 °C  |
| Min. working pressure                  | 1 bar  |

# Mini cylinder, Series ICM

R402001230

Series ICM

2024-06-21

---

|                                    |                     |
|------------------------------------|---------------------|
| Max. working pressure              | 10 bar              |
| Weight 0 mm stroke                 | 0.08 kg             |
| Weight +10 mm stroke               | 0.01 kg             |
| Stroke max.                        | 400 mm              |
| Medium                             | Compressed air      |
| Min. medium temperature            | -20 °C              |
| Max. medium temperature            | 70 °C               |
| Max. particle size                 | 50 µm               |
| Min. oil content of compressed air | 0 mg/m <sup>3</sup> |

## Material

|                           |                                |
|---------------------------|--------------------------------|
| Piston rod                | Stainless Steel                |
| Scraper material          | Polyurethane                   |
| Seal material             | Acrylonitrile butadiene rubber |
| Material, front cover     | Polyoxymethylene               |
| Cylinder tube             | Stainless Steel                |
| End cover                 | Polyoxymethylene               |
| Connection thread         | Stainless Steel                |
| Nut for cylinder mounting | Polyamide                      |
| Nut for piston rod        | Stainless Steel                |
| Part No.                  | R402001230                     |

## Technical information

Nut MR3 included in supply

The pressure dew point must be at least 15 °C less than ambient and medium temperature and may not exceed 3 °C.

The oil content of compressed air must remain constant during the life cycle.

Use only the approved oils from AVENTICS. Further information can be found in the “Technical information” document (available in <https://www.emerson.com/en-us/support>).

# Mini cylinder, Series ICM

R402001230

Series ICM

2024-06-21

## Dimensions



S = stroke

| Piston Ø | AM +0/-2 | BE      | BF | CD H11 | D    | E    | EE    | EW d13 | FV |
|----------|----------|---------|----|--------|------|------|-------|--------|----|
| 12       | 16       | M16x1,5 | 20 | 6      | 10   | 13.5 | M5    | 12     | 20 |
| 16       | 16       | M16x1,5 | 20 | 6      | 12   | 14   | M5    | 12     | 24 |
| 20       | 20       | M22x1,5 | 22 | 8      | 15   | 18   | G 1/8 | 16     | 30 |
| 25       | 27       | M22x1,5 | 22 | 8      | 17   | 18   | G 1/8 | 16     | 34 |
| 32       | 32       | M30x1,5 | 29 | 10     | 22.5 | 24   | G 1/8 | 26     | 46 |

| Piston Ø | KK       | KV | KW | L  | MM | MR  | N  | NL   | NV |
|----------|----------|----|----|----|----|-----|----|------|----|
| 12       | M6       | 24 | 7  | 9  | 6  | 7.5 | 5  | 7    | 4  |
| 16       | M6       | 24 | 7  | 9  | 6  | 7.5 | 5  | 6    | 4  |
| 20       | M8       | 30 | 8  | 12 | 8  | 10  | 8  | 7    | 6  |
| 25       | M10x1,25 | 30 | 8  | 12 | 10 | 10  | 8  | 6.5  | 8  |
| 32       | M10x1,25 | 41 | 11 | 13 | 12 | 15  | 10 | 10.5 | 11 |

| Piston Ø | OF max. | WF ±1,2 | XC ±1 |
|----------|---------|---------|-------|
| 12       | 10      | 22      | 75    |
| 16       | 10      | 22      | 82    |
| 20       | 10      | 24      | 95    |
| 25       | 10      | 23      | 104   |
| 32       | 14      | 38      | 128   |

# Mini cylinder, Series ICM

R402001230

Series ICM

2024-06-21

## Overview drawing

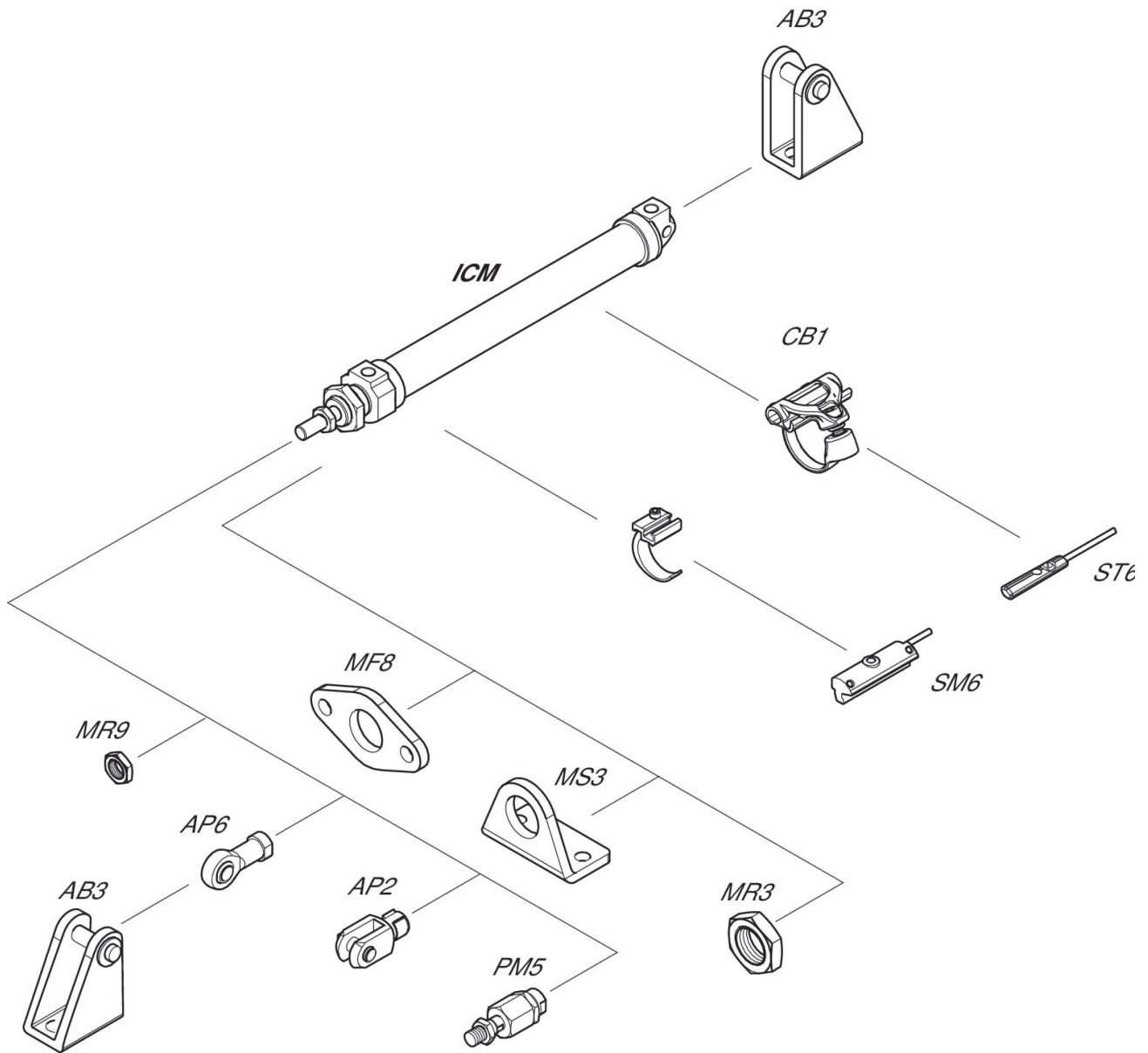

NOTE: This overview drawing is only for orientation to indicate where the various accessory parts can be fastened to the cylinder. The illustration has been simplified for this purpose. It is thus not possible to derive the dimensions from this overview.