

Series IS12-PM, size 1

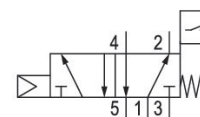

Technical data

Industry	Industrial
Activation	Electrically
Nominal flow Qn	2500 l/min
Compressed air connection output	Base plate DIN ISO 5599 size 2
Min. working pressure	3 bar
Max. working pressure	10 bar
Manual override	without
Actuating control	Single Solenoid
Sealing principle	Soft seal
Pilot	Internal
Standards	ISO 5599-1
Pilot valve width	30 mm
Valve type	Spool valve, positive overlapping
Blocking principle	Single base plate principle
Connection type	Plate connection
Return	with differential piston
Compressed air connection input	Base plate DIN ISO 5599 size 2
Compressed air connection, exhaust	Base plate DIN ISO 5599 size 2
Compressed air connection pilot input	Base plate DIN ISO 5599 size 2

5/2-directional valve, Series IS12-PD, size 2

2024-03-18

R422003653

Compressed air connection pilot exhaust	M5
Basic valve equipment	Basic valve without coil
Frame size	ISO 2
Min. control pressure	3 bar
Max. control pressure	10 bar
Min. ambient temperature	0 °C
Max. ambient temperature	50 °C
Min. medium temperature	0 °C
Max. medium temperature	60 °C
Medium	Compressed air
Max. particle size	5 µm
Min. oil content of compressed air	0 mg/m ³
Max. oil content of compressed air	0.01 mg/m ³
Protection class with connection	IP65
Compatibility index	15
Duty cycle	100 %
Switch-on time	20 ms
Switch-off time	50 ms
Type sensor	electronic PNP, with LED
Electrical connection for sensor	Plug
Sensor port size	M8
Sensor number of poles	3-pin
Voltage drop sensor U at I _{max}	≤ 2,5 V
Vibration resistance sensor	10 - 55 Hz, 1 mm
Shock resistance sensor	30 g / 11 ms
Protection class sensor acc. to DIN EN 61140	Class III
Sensor	with knurled screw
Cable length sensor	0.3 m
Mounting screws	M6 with hexagon socket
Weight	0.52 kg
Housing material	Polyamide Aluminum
Seal material	Acrylonitrile butadiene rubber
Part No.	R422003653

Technical information

When the valve is not actuated, the sensor sends a signal through pin 4 of the sensor connection.

When the valve is actuated, the sensor does not send a signal through pin 4 of the sensor connection.

The valve with position detection is possible to be used in categories 3 and 4 according to ISO 13849 in order to reach a Performance Level (PL) of the control system up to PL = e.

On its own, the valve with position detection is not a safety component and is not a complete safety solution. It is designed to increase the diagnostic coverage (DC) of the control system.

For use in categories 3 to 4, additional requirements of DIN EN ISO 13849-1:2008-12 (e.g. CCF, DC, PLr, software, systematic errors) are taken into consideration by the user.

The min. control pressure must be adhered to, since otherwise faulty switching and valve failure may result!

The pressure dew point must be at least 15 °C less than ambient and medium temperature and may not exceed 3 °C.

The oil content of compressed air must remain constant during the life cycle.

Use only the approved oils from AVENTICS. Further information can be found in the "Technical information" document (available in <https://www.emerson.com/en-us/support>).

Dimensions

5/2-directional valve, Series IS12-PD, size 2

2024-03-18

R422003653

Fig. 2

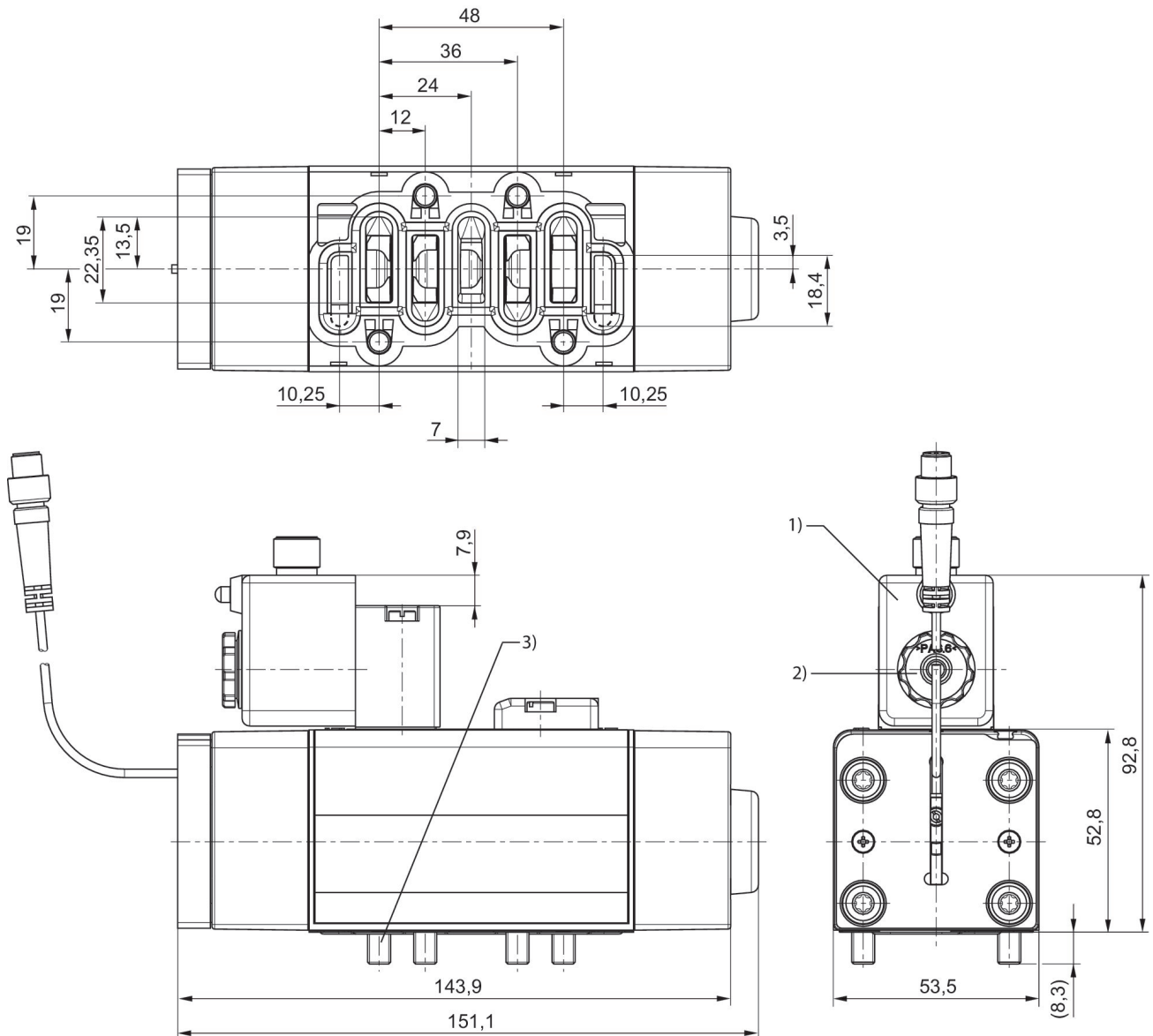

- 1) Adjustable coil 3x90°
- 2) Tightening torque for lock nut: 0.6 + 0.2 Nm
- 3) Tightening torque for mounting screws: 4.0 ± 0.5 Nm

Dimensions

5/2-directional valve, Series IS12-PD, size 2

2024-03-18

R422003653

Fig. 1

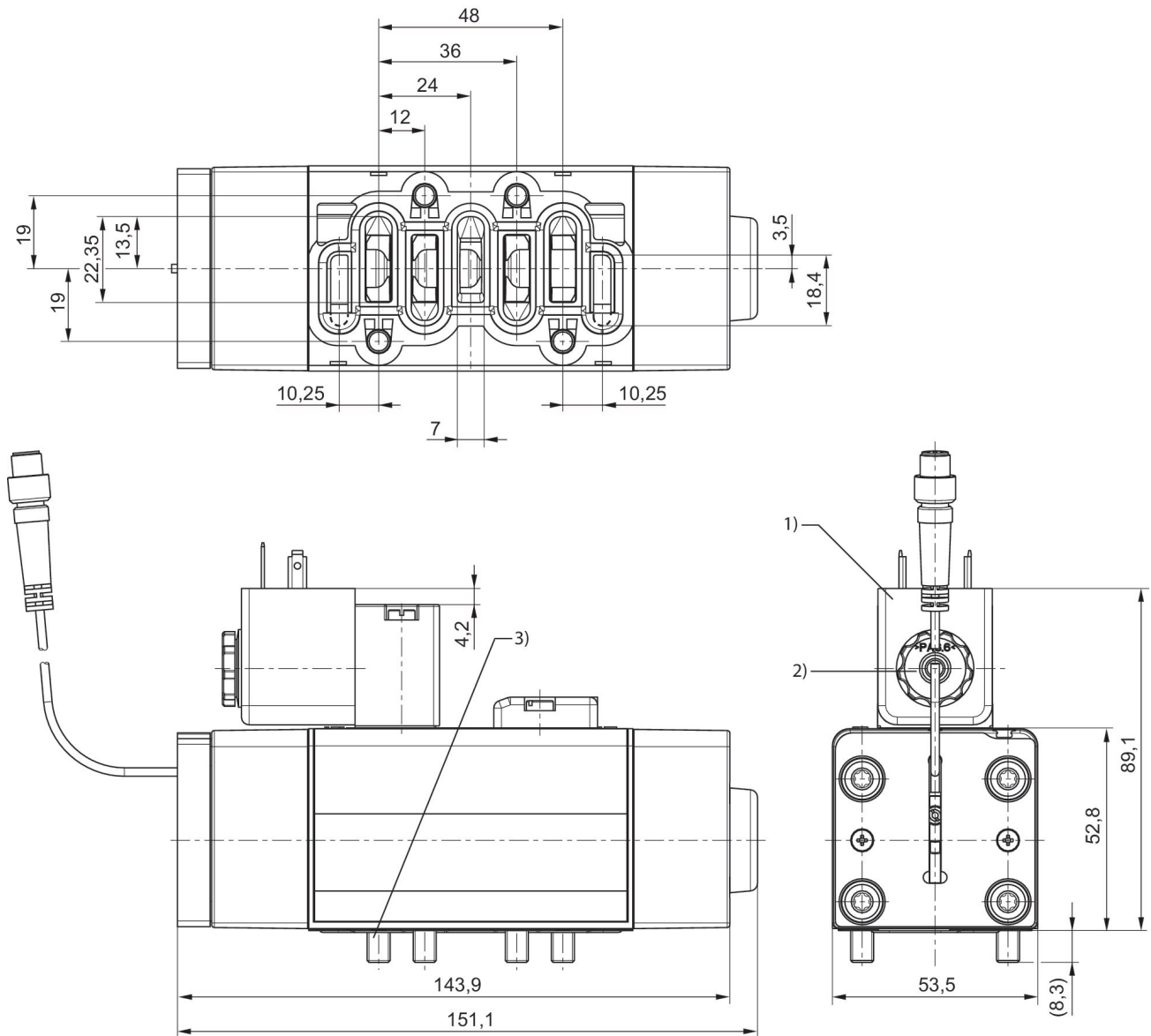

- 1) Adjustable coil 3x90°
- 2) Tightening torque for lock nut: 0.6 + 0.2 Nm
- 3) Tightening torque for mounting screws: 4.0 ± 0.5 Nm