

Mini slide, Series MSC-MG-PM/PE

R480640159

AVENTICS
Series
MSC Guide
cylinders

2024-04-06

AVENTICS Series MSC Guide cylinders

The AVENTICS Series MSC mini slides have a compact design, require minimal installation space and can be optimally configured for virtually any automated handling task. A wide range of configuration options make the mini slide a truly universal handling component. Precise and reliable operation, coupled with a custom configuration and tailored to the specific application – these attributes allow the mini slides to assume the actuator role in efficient handling. The Series MSC offers high torque absorption and maximum stability. In addition, it provides technical features that guarantee optimally adjusted functions and maintenance-friendly processes. Fast, secure and efficiently connected with the special Easy-2-Combine Interface, the mini slides can be combined with the other components of a handling system without additional mounting plates.



Technical data

Industry	Industrial
Note	Scope of delivery: incl. centering rings
Piston Ø	20 mm
Stroke	100 mm
Functional principle	Double-acting
Easy2Combine	capable
double piston	with double piston
Port	G 1/8
Cushioning	Pneumatically
Repetitive precision	0,3 mm
Min. working pressure	3 bar
Max. working pressure	10 bar
Min. ambient temperature	0 °C
Max. ambient temperature	60 °C
Medium	Compressed air
Retracting piston force, theoretical	297 N
Extracting piston force, theoretical	269 N
Max. speed	0.8 m/s
Cushioning length	7 mm

Mini slide, Series MSC-MG-PM/PE

R480640159

AVENTICS
Series
MSC Guide
cylinders

2024-04-06

Cushioning energy	1.2 J
Min. oil content of compressed air	0 mg/m ³
Max. oil content of compressed air	1 mg/m ³
Max. particle size	5 µm
Pressure for determining piston forces with integrated ball rail guide	6,3 bar with integrated ball rail guide
Weight	2.23 kg

Material

Housing material	Aluminum
Surface housing	anodized
Material piston rod	Stainless Steel
Material front plate	Aluminum
Surface front plate	anodized
Seal material	Polyurethane
Material ball rail table	Aluminum
Surface ball rail table	anodized
Material guide rail	Steel, chrome-plated
Surface guide rail	hardened
Material centering rings	Stainless Steel
Part No.	R480640159

Technical information

Repetitive precision after 100 consecutive strokes: 0,02 mm

Repeatability with variant with elastomer end stop: 0.3 mm

Cushioning length for variant with elastomer end stop: 10.5 mm

Base with air connections at the back and sides

Intermediate strokes can be configured.

Scope of delivery: incl. centering rings

R1 = stroke setting range for forward stroke

R2 = stroke setting range for return stroke

The pressure dew point must be at least 15 °C less than ambient and medium temperature and may not exceed 3 °C.

The oil content of compressed air must remain constant during the life cycle.

Use only the approved oils from AVENTICS. Further information can be found in the "Technical information" document (available in <https://www.emerson.com/en-us/support>).

Dimensions

Mini slide, Series MSC-MG-PM/PE

R480640159

MSC-25

AVENTICS
Series
MSC Guide
cylinders

2024-04-06

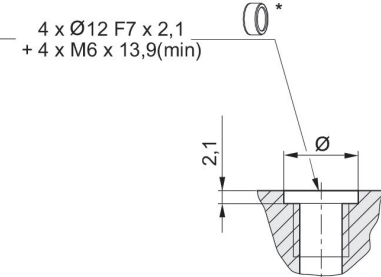
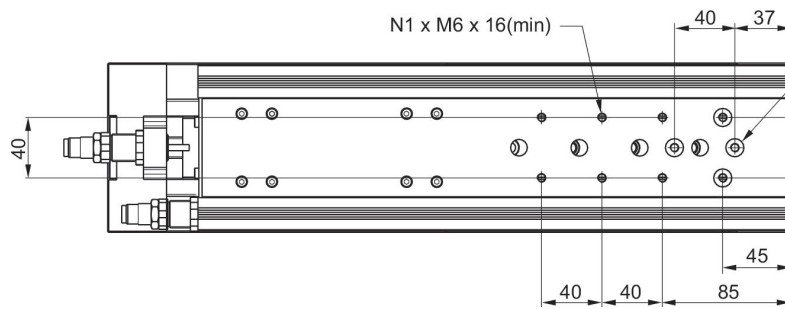
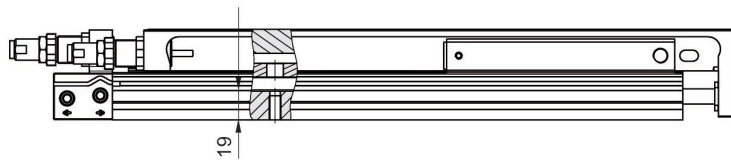
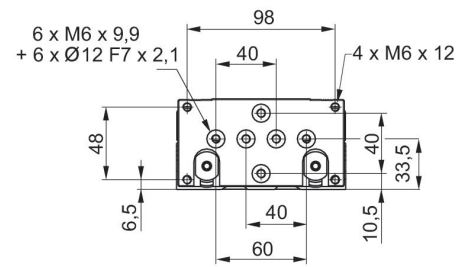
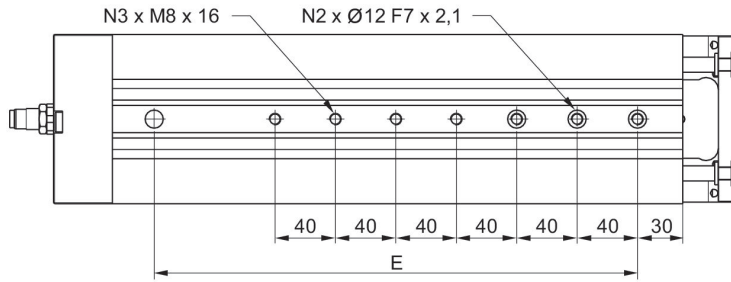

* = centering rings

Part No.	Piston Ø	S	N1	N2	N3
R480640160	25	50	4	2	2
R480640161	25	80	4	3	3
R480640162	25	100	4	3	3

S = stroke

Dimensions

Mini slide, Series MSC-MG-PM/PE

R480640159

MSC-20

AVENTICS
Series
MSC Guide
cylinders

2024-04-06

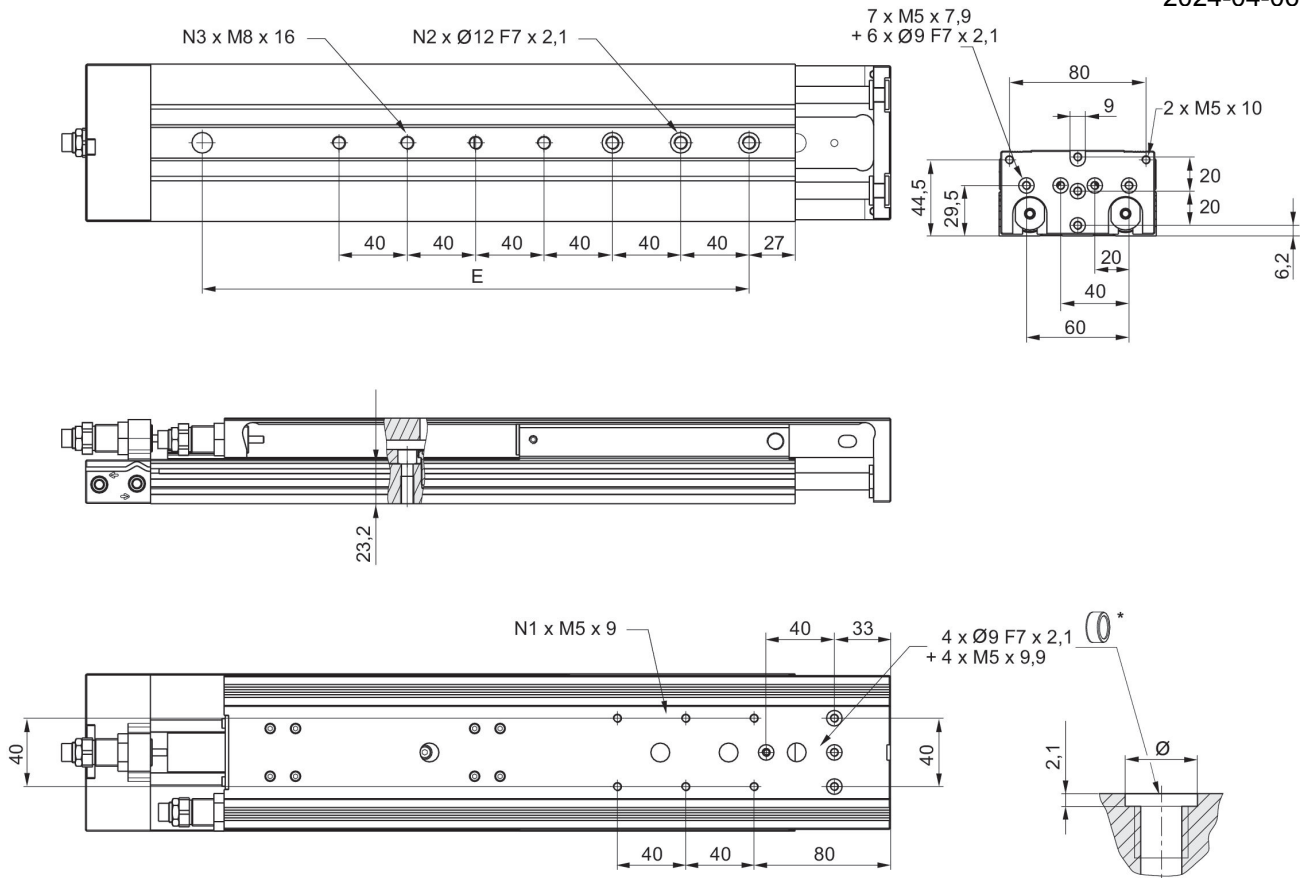

* = centering rings

Part No.	Piston Ø	Stroke	N1	N2	N3
R480640157	20	50	2	2	2
R480640158	20	80	4	3	3
R480640159	20	100	4	3	3

Dimensions

Mini slide, Series MSC-MG-PM/PE

R480640159

MSC-16

AVENTICS
Series
MSC Guide
cylinders

2024-04-06

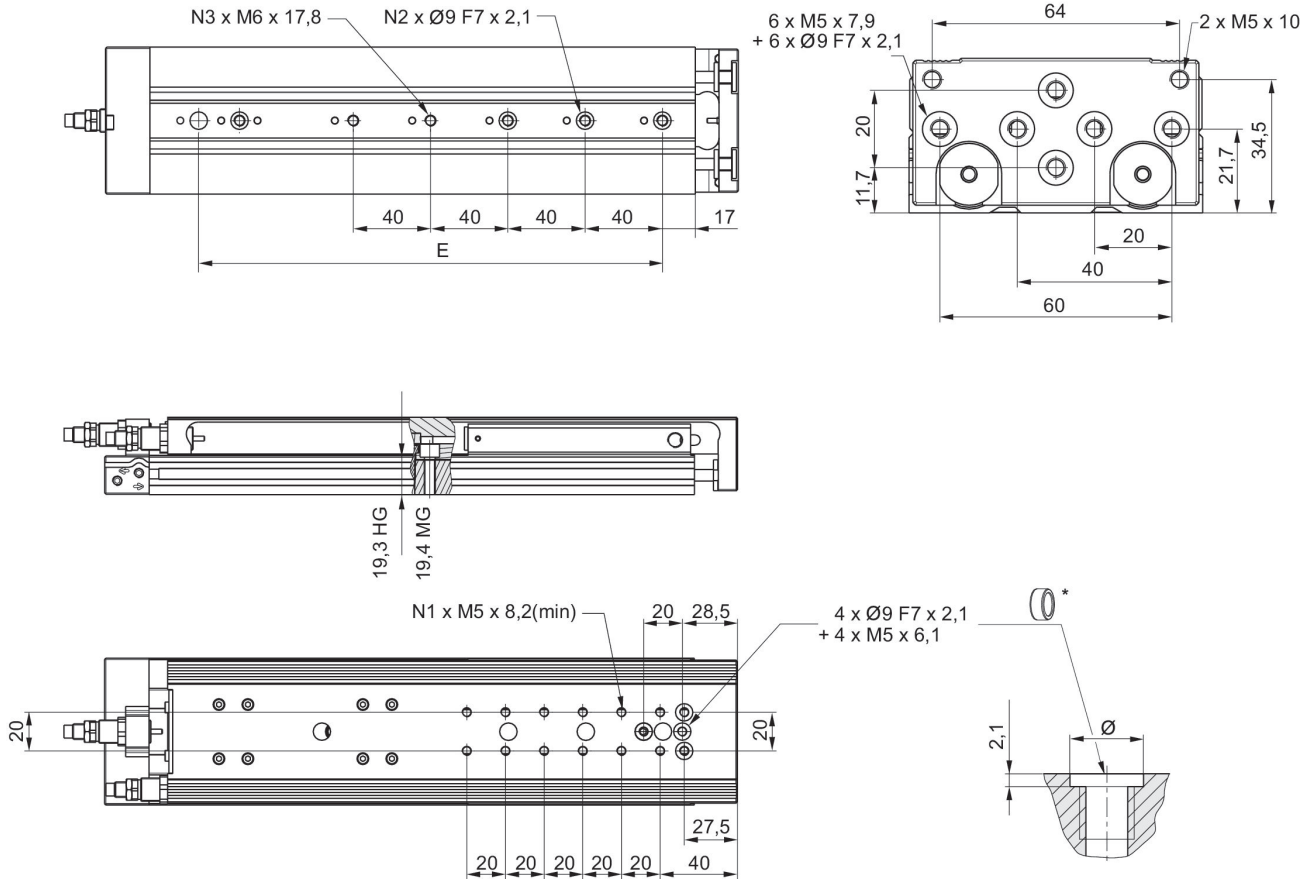

* = centering rings

Part No.	Piston Ø	S	N1	N2	N3
R480640154	16	50	4	2	2
R480640155	16	80	6	3	3
R480640156	16	100	8	3	3

S = stroke

Mini slide, Series MSC-MG-PM/PE

R480640159

AVENTICS
Series
MSC Guide
cylinders

2024-04-06

Dimensions

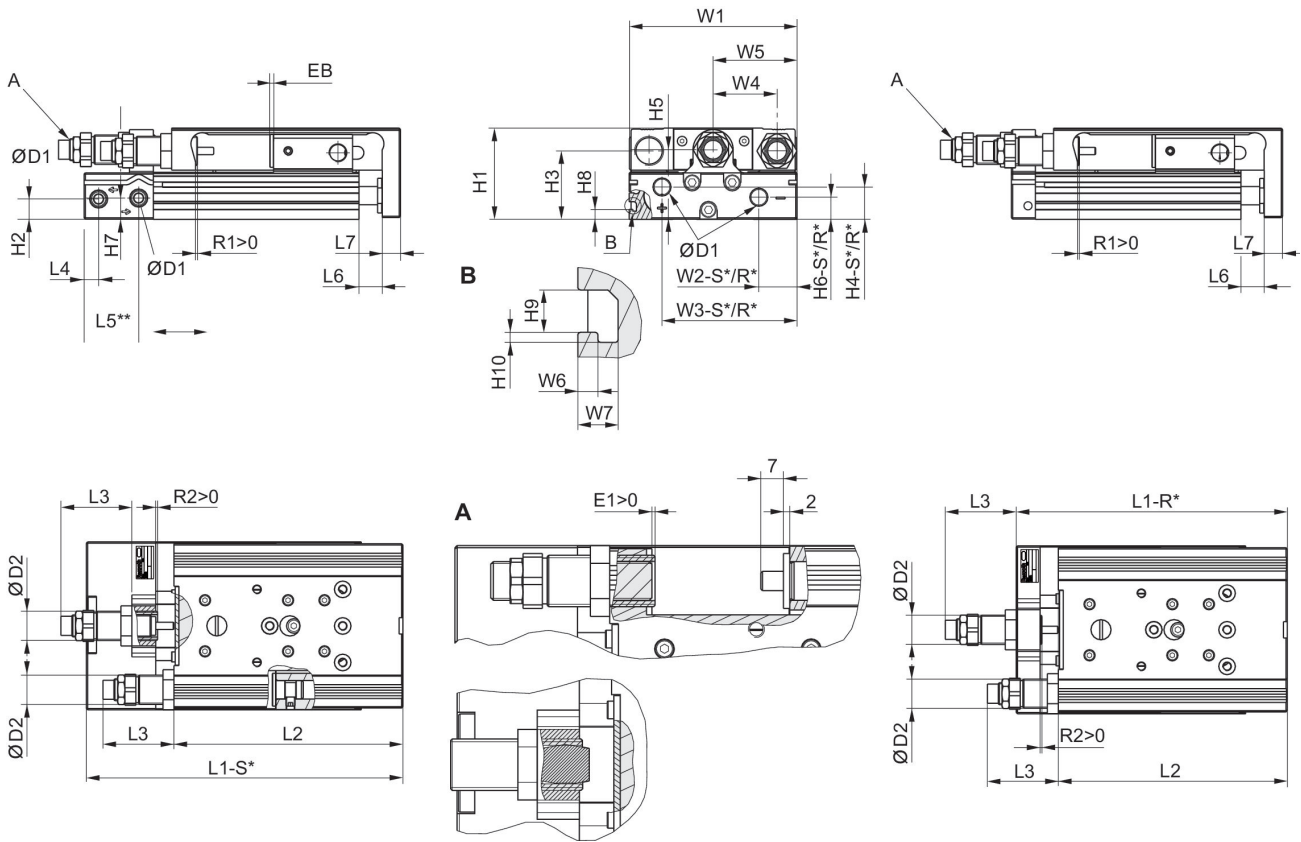

R*: base with air connections only at the back
S*: base with air connections at the back and sides

Piston Ø	Ø D1	Ø D2	H1	H2	H3	H4-R	H4-S	H5	H6-R
16	M5	M12x1	40	7.2	29	12.2	12.2	31	7.7
20	G 1/8	M16x1,5	50	11.2	37.5	17.3	17.3	38.2	11.7
25	G 1/8	M18x1,5	60	14.2	44	15.5	22.9	46.5	13.2

Piston Ø	H6-S	H7	H8	H9	H10	L3 1) max.	L3 2) max.	L4	L5 3)
16	7.7	11.2	-	-	-	12	47	6.5	17.7
20	12.2	11.7	5.5	4.2	1	15	57	8	30
25	21.7	16.2	6.9	5.2	1.5	15	62	9	31

Piston Ø	L6	L7	R2	W1	W2-R	W2-S	W3-R	W3-S	W4
16	2	10	3	76	31	31	60.5	60.5	30
20	2.1	10	3	92	10	21	74	74	35
25	2.1	12	3	112	11	14	92	92	44

Piston Ø	W5	W6	W7
16	W1/2	-	-
20	W1/2	2	4
25	W1/2	2.5	4.8

Stroke-dependent dimensions

Piston Ø	S=50 EB	S=80 EB	S=100 EB	S=50 L1-R	S=80 L1-R	S=100 L1-R	S=50 L1-S	S=80 L1-S	S=100 L1-S
16	2	2	2	126.8	172.8	192.8	137.7	183.7	203.7
20	2	2	2	137.9	182.9	202.9	162.8	207.8	227.8
25	2	2	2	149.1	195.1	215.1	172.8	218.8	238.8

Piston Ø	S=50 L2	S=80 L2	S=100 L2	S=50 R1 max.	S=80 R1 max.	S=100 R1 max.
16	115.4	161.4	181.4	8.7	8.7	8.7
20	125.5	170.5	190.5	12.4	12.4	12.4
25	134.5	180.5	200.5	10.5	11.5	11.5

Correction factor (a, d) vertical

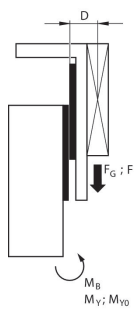

stat.	$M_{B0} = (F_G + F) \cdot D$
dyn.	$M_B = F_G \cdot D$

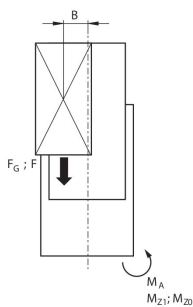

stat.	$M_{A0} = (F_G + F) \cdot B$
dyn.	$M_A = F_G \cdot B$

dyn.	$\frac{M_A}{M_1} + \frac{M_B}{M_2} \leq 1$
stat.	$\frac{M_{A0}}{M_{Z0}} + \frac{M_{B0}}{M_{Y0}} \leq 1$

$F = m \cdot a$ $F_G = m \cdot g$ $a = 1250 \cdot V^2 / H$
 F = deceleration force [N] F_G = force due to weight [N] m = load mass [kg] a = deceleration [m/s²] g = gravitational acceleration 9,81 [m/s²] V = velocity [m/s] H = stroke length of shock absorber [mm]

Correction factor (a, d) horizontal

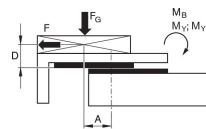

stat.	$M_{B0} = F_G \cdot A + F \cdot D$
dyn.	$M_B = F_G \cdot A$

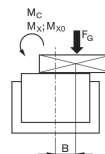

stat.	$M_{C0} = F_G \cdot B$
dyn.	$M_C = F_G \cdot B$

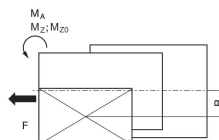

stat.	$M_{A0} = F \cdot B$
dyn.	$M_A = 0$

dyn.	$\frac{M_A}{M_1} + \frac{M_B}{M_2} + \frac{M_C}{M_3} \leq 1$
stat.	$\frac{M_{A0}}{M_{Z0}} + \frac{M_{B0}}{M_{Y0}} + \frac{M_{C0}}{M_{X0}} \leq 1$

$F = m \cdot a$ $F_G = m \cdot g$ $a = 1250 \cdot V^2 / H$
 F = deceleration force [N] F_G = force due to weight [N] m = load mass [kg] a = deceleration [m/s²] g = gravitational acceleration 9,81 [m/s²] V = velocity [m/s] H = stroke length of shock absorber [mm]

Mini slide, Series MSC-MG-PM/PE

R480640159

AVENTICS
Series
MSC Guide
cylinders

2024-04-06

Correction factor (a, d)

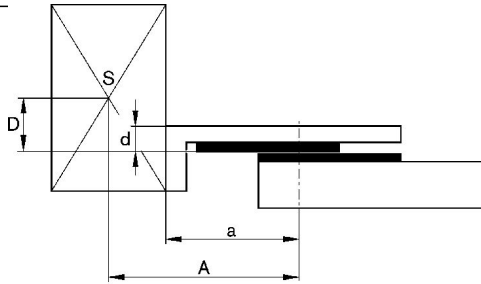

Maximum moving mass

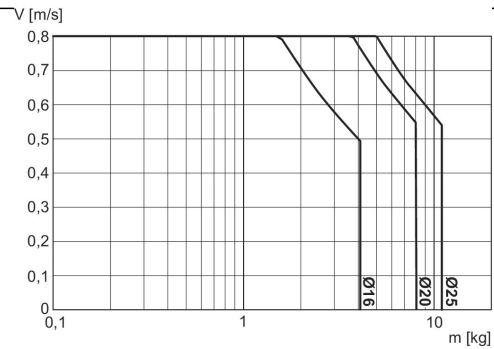

V = velocity [m/s]
m = mass

Correction factor for required speed: retracting and extending, horizontal

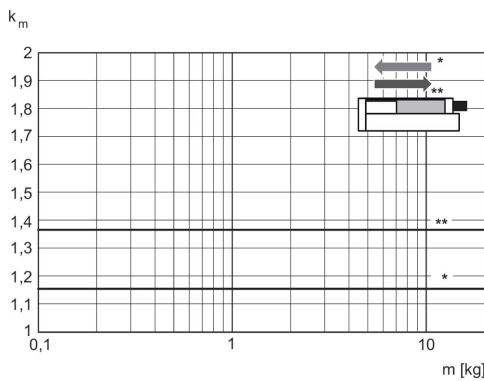

* retracting
** extracting
 $V = s/1000 \cdot t \cdot km$
V = velocity [m/s]
S = stroke

Correction factor for required speed: extending, vertical, downwards

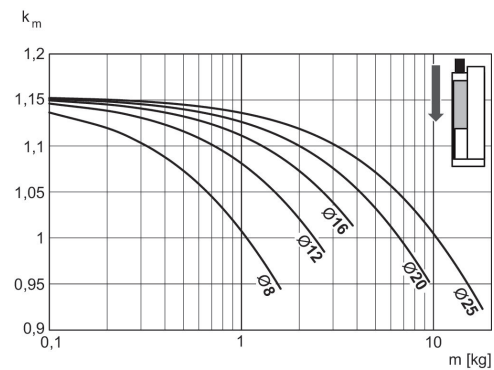

$V = s/1000 \cdot t \cdot km$
V = velocity [m/s]
S = stroke [mm]
t = time [s] for one stroke
m = mass

Mini slide, Series MSC-MG-PM/PE

R480640159

AVENTICS
Series
MSC Guide
cylinders
2024-04-06

Correction factor for required speed:
retracting, vertical, downwards

Correction factor for required speed:
retracting, vertical, upwards

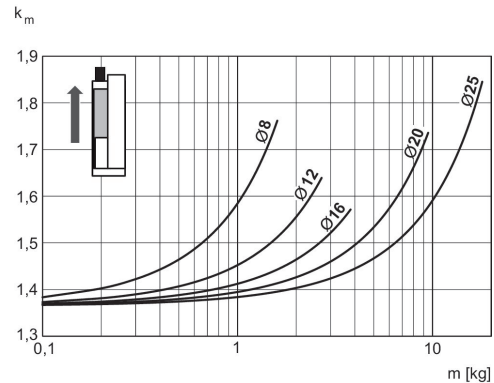
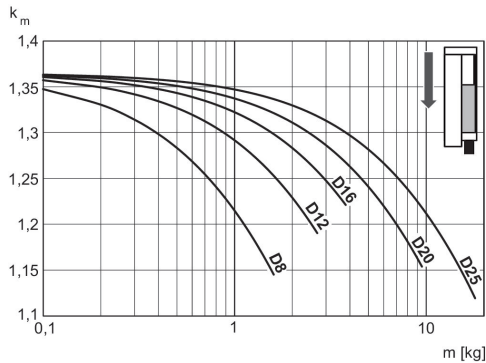

$V = s/1000 \cdot t \cdot k_m$
V = velocity [m/s]
S = stroke [mm]
t = time [s] for one stroke
m = mass

$V = s/1000 \cdot t \cdot k_m$
V = velocity [m/s]
S = stroke [mm]
t = time [s] for one stroke
m = mass

Correction factor for required speed:
extending, vertical, upwards

Max. extracting speed

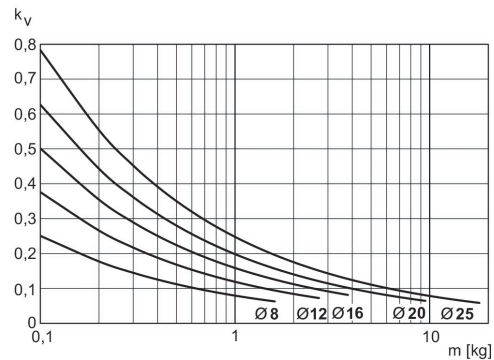
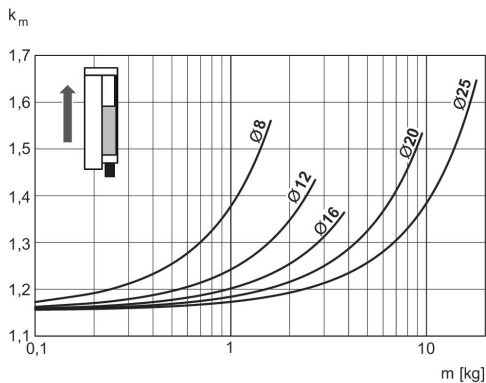

$V = s/1000 \cdot t \cdot k_m$
V = velocity [m/s]
S = stroke [mm]
t = time [s] for one stroke
m = mass

$V = \sqrt{s \cdot k_v}$
V = velocity [m/s]
S = stroke [mm]
m = mass

Load capacity

Mini slide, Series MSC-MG-PM/PE

R480640159

AVENTICS
Series
MSC Guide
cylinders

2024-04-06

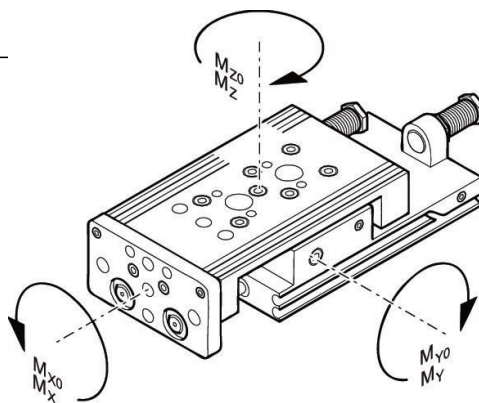

M = max. permissible torque

Correction factor (a)

Piston Ø	Stroke	a [mm]	d [mm]	Mx0 Static moment M [Nm]	My0 Static moment M [Nm]	Mz0 Static moment M [Nm]	Mx Dynamic moment M [Nm]	My Dynamic moment M [Nm]	Mz Dynamic moment M [Nm]
16	50	86	15	31,6	11,95	11,95	7	3,2	3,2
20	50	92	20	31,6	11,95	11,95	10	4	4
25	50	102	24	87	24,5	24,5	15,3	6,6	6,6

Mini slide, Series MSC-MG-PM/PE

R480640159

AVENTICS
Series
MSC Guide
cylinders

2024-04-06

Overview drawing

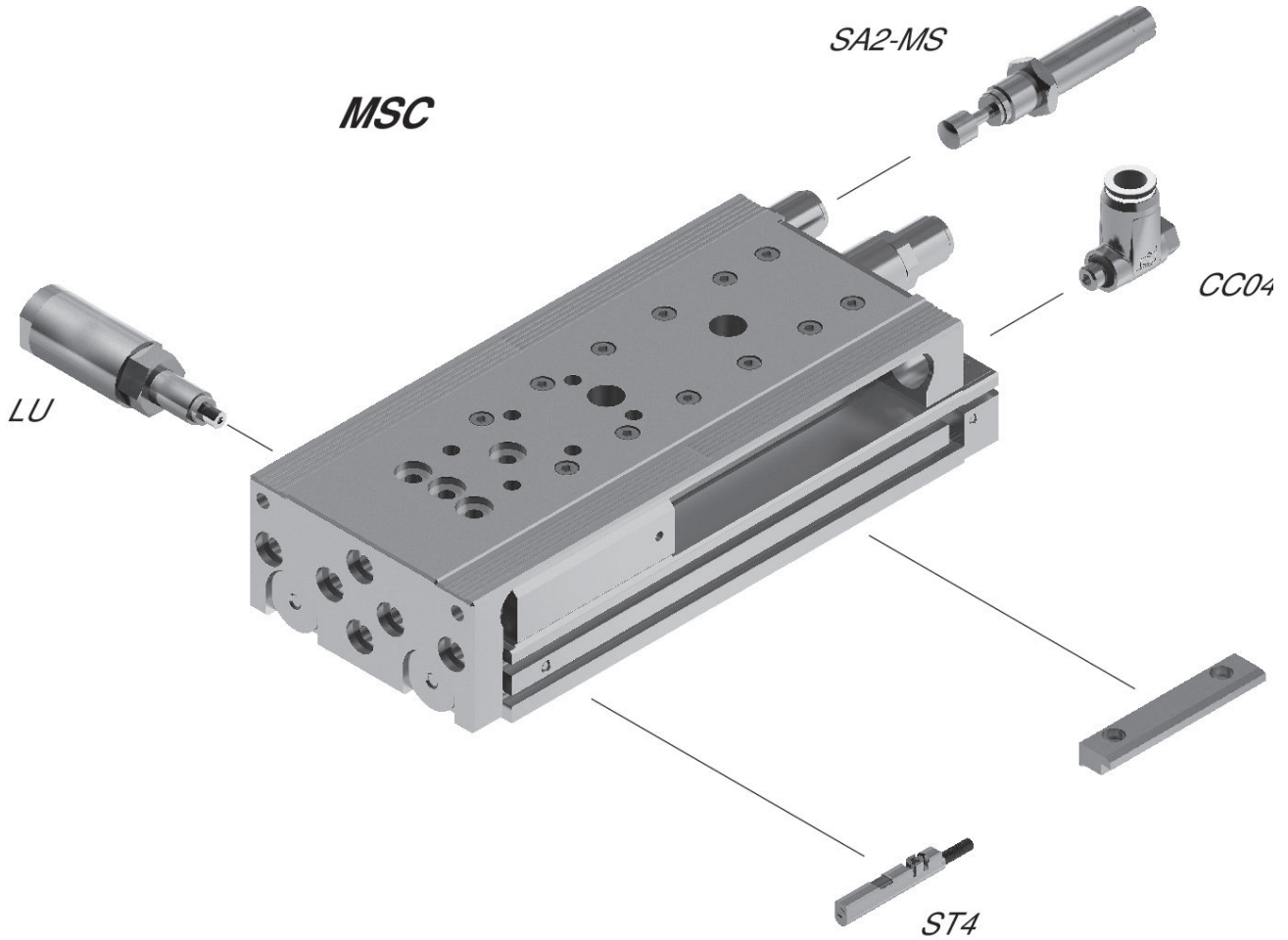

NOTE: This overview drawing is only for orientation to indicate where the various accessory parts can be fastened to the cylinder. The illustration has been simplified for this purpose. It is thus not possible to derive the dimensions from this overview.

Weight of moving parts [kg]

Part No.	Piston Ø	S=10	S=20	S=30	S=40	S=50	S=80	S=100	S=125
R480640154	16	0.375	0.375	0.375	0.4	0.45	0.615	0.65	0.725
R480640155	16	0.375	0.375	0.375	0.4	0.45	0.615	0.65	0.725
R480640156	16	0.375	0.375	0.375	0.4	0.45	0.615	0.65	0.725
R480640157	20	0.655	0.655	0.655	0.69	0.765	0.985	1.035	1.2
R480640158	20	0.655	0.655	0.655	0.69	0.765	0.985	1.035	1.2
R480640159	20	0.655	0.655	0.655	0.69	0.765	0.985	1.035	1.2
R480640160	25	1.1	1.1	1.1	1.1	1.225	1.45	1.625	1.885
R480640161	25	1.1	1.1	1.1	1.1	1.225	1.45	1.625	1.885
R480640162	25	1.1	1.1	1.1	1.1	1.225	1.45	1.625	1.885
repeat- Column tablefooter									

Mini slide, Series MSC-MG-PM/PE

R480640159

AVENTICS
Series
MSC Guide
cylinders

2024-04-06

S=150	S=200
2.085	2.445
2.085	2.445
2.085	2.445
2.085	2.445
2.085	2.445
2.085	2.445
2.085	2.445
2.085	2.445
2.085	2.445
2.085	2.445
2.085	2.445
2.085	2.445
2.085	2.445
2.085	2.445
2.085	2.445
2.085	2.445

S = stroke