

# Mini slide, Series MSC-HG-PM/PE

R480640206

AVENTICS  
Series  
MSC Guide  
cylinders

2024-04-06

## AVENTICS Series MSC Guide cylinders

The AVENTICS Series MSC mini slides have a compact design, require minimal installation space and can be optimally configured for virtually any automated handling task. A wide range of configuration options make the mini slide a truly universal handling component. Precise and reliable operation, coupled with a custom configuration and tailored to the specific application – these attributes allow the mini slides to assume the actuator role in efficient handling. The Series MSC offers high torque absorption and maximum stability. In addition, it provides technical features that guarantee optimally adjusted functions and maintenance-friendly processes. Fast, secure and efficiently connected with the special Easy-2-Combine Interface, the mini slides can be combined with the other components of a handling system without additional mounting plates.



## Technical data

Industry	Industrial
Piston Ø	20 mm
Stroke	150 mm
Functional principle	Double-acting
Easy2Combine	capable
double piston	with double piston
Port	G 1/8
Cushioning	Pneumatically
Repetitive precision	0,3 mm
Min. working pressure	3 bar
Max. working pressure	10 bar
Min. ambient temperature	0 °C
Max. ambient temperature	60 °C
Medium	Compressed air
Retracting piston force, theoretical	297 N
Extracting piston force, theoretical	269 N
Max. speed	0.8 m/s
Cushioning length	7 mm
Cushioning energy	1.2 J

# Mini slide, Series MSC-HG-PM/PE

R480640206

AVENTICS  
Series  
MSC Guide  
cylinders

2024-04-06

Min. oil content of compressed air	0 mg/m <sup>3</sup>
Max. oil content of compressed air	1 mg/m <sup>3</sup>
Max. particle size	5 µm
Pressure for determining piston forces with integrated ball rail guide	6,3 bar With integrated "High Performance" ball rail system
Weight	3.36 kg

## Material

Housing material	Aluminum
Surface housing	anodized
Material piston rod	Stainless Steel
Material front plate	Aluminum
Surface front plate	anodized
Seal material	Polyurethane
Material ball rail table	Aluminum
Surface ball rail table	anodized
Material guide rail	Steel, chrome-plated
Surface guide rail	hardened
Material centering rings	Stainless Steel
Part No.	R480640206

## Technical information

Repetitive precision after 100 consecutive strokes: 0,02 mm

Repeatability with variant with elastomer end stop: 0.3 mm

Cushioning length for variant with elastomer end stop: 10.5 mm

Base with air connections at the back and sides

Intermediate strokes can be configured.

Scope of delivery: incl. centering rings

R1 = stroke setting range for forward stroke

R2 = stroke setting range for return stroke

PE: cushioning: pneumatic, end stop: elastomer

PM: cushioning: pneumatic, end stop: metal

The pressure dew point must be at least 15 °C less than ambient and medium temperature and may not exceed 3 °C.

The oil content of compressed air must remain constant during the life cycle.

Use only the approved oils from AVENTICS. Further information can be found in the "Technical information" document (available in <https://www.emerson.com/en-us/support>).

## Dimensions

# Mini slide, Series MSC-HG-PM/PE

R480640206

MSC-25

AVENTICS  
Series  
MSC Guide  
cylinders

2024-04-06

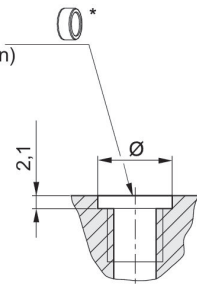
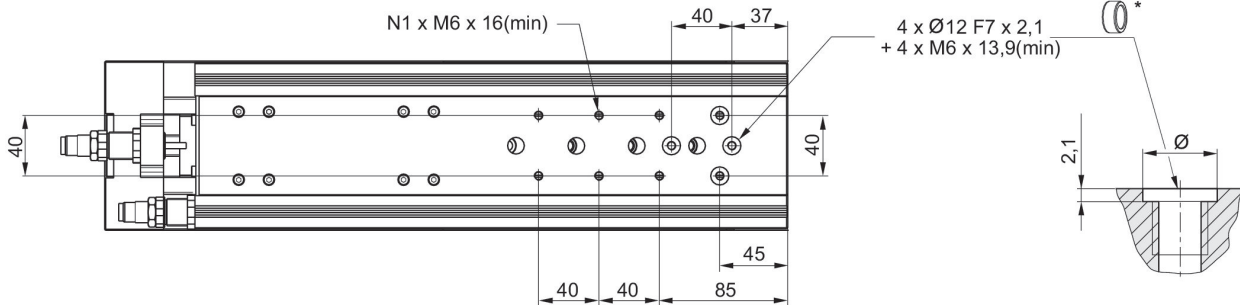
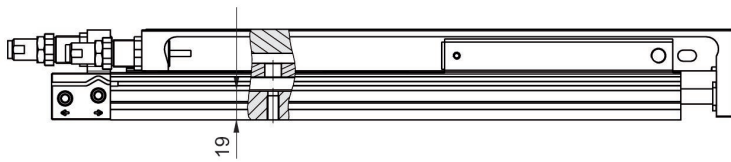
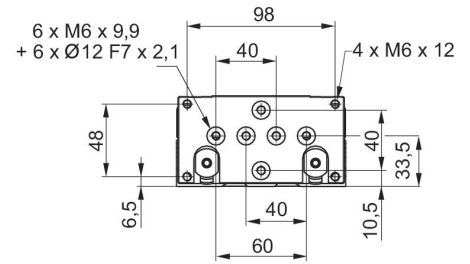
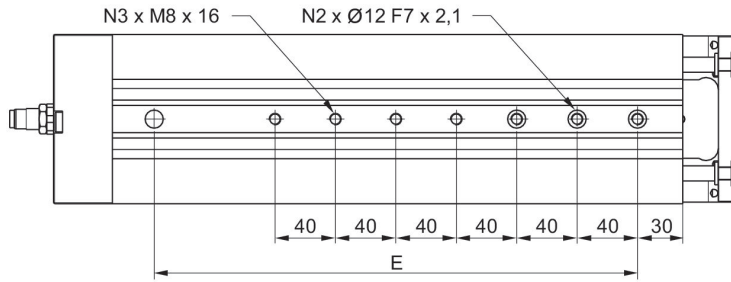

\* = centering rings

Part No.	Piston Ø	Stroke	E	N1	N2	N3
R412019030	25	125	200	4	4	5
R480643827	25	125	200	4	4	5
R412019041	25	125	200	4	4	5
R480640211	25	125	200	4	4	5
R412019031	25	150	240	6	4	5
R480643828	25	150	240	6	4	5
R412019042	25	150	240	6	4	5
R480640212	25	150	240	6	4	5
R412019032	25	200	320	6	4	7
R480643829	25	200	320	6	4	7
R412019043	25	200	320	6	4	7
R480640213	25	200	320	6	4	7

## Dimensions

# Mini slide, Series MSC-HG-PM/PE

R480640206

MSC-20

AVENTICS  
Series  
MSC Guide  
cylinders

2024-04-06

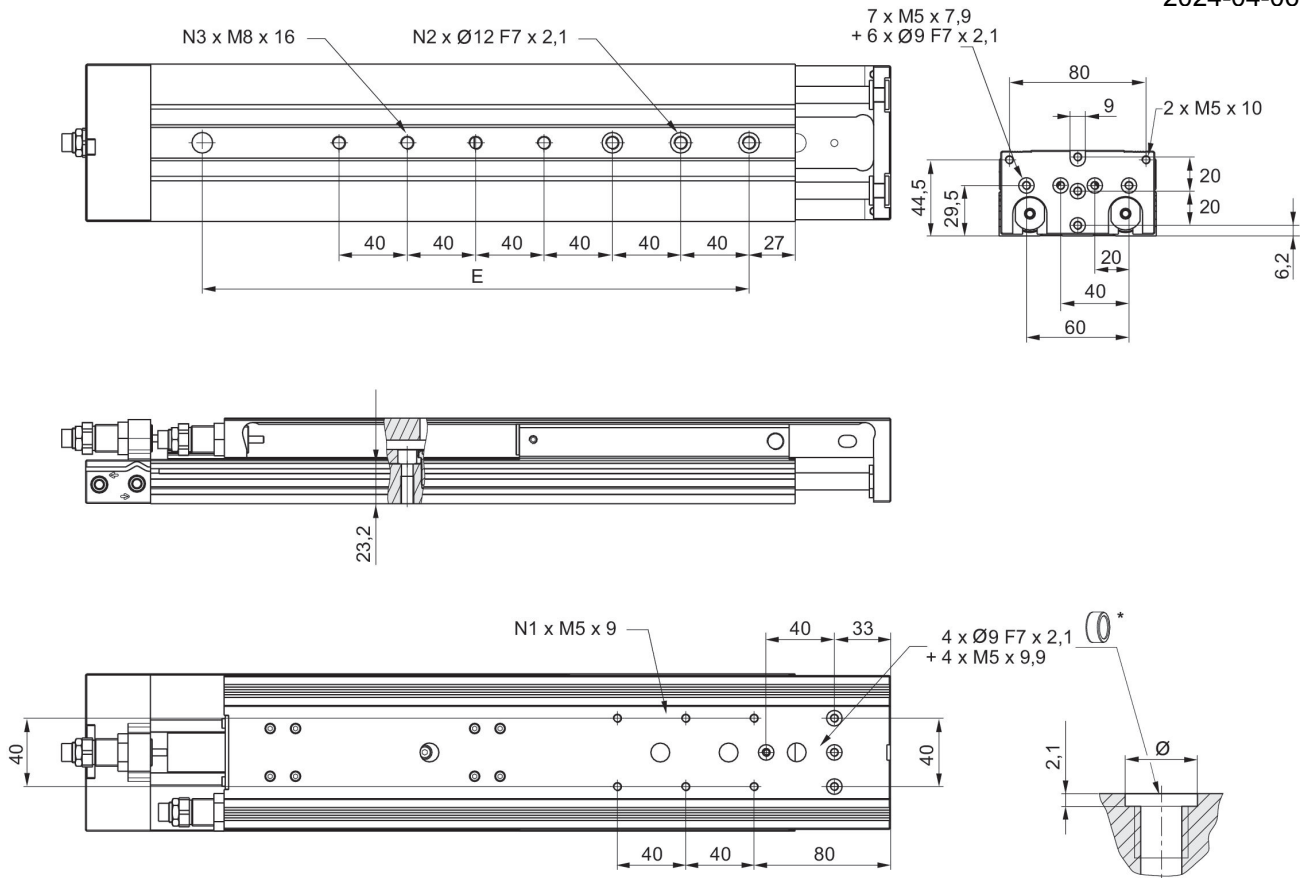

\* = centering rings

Part No.	Piston Ø	Stroke	E	N1	N2	N3
R412018917	20	125	200	6	4	5
R480643817	20	125	200	6	4	5
R412019005	20	125	200	6	4	5
R480640205	20	125	200	6	4	5
R412018918	20	150	240	6	4	5
R480643818	20	150	240	6	4	5
R412019006	20	150	240	6	4	5
R480640206	20	150	240	6	4	5
R412018919	20	200	320	6	4	7
R480643819	20	200	320	6	4	7
R412019007	20	200	320	6	4	7
R480640207	20	200	320	6	4	7

## Dimensions

# Mini slide, Series MSC-HG-PM/PE

R480640206

MSC-16

AVENTICS  
Series  
MSC Guide  
cylinders

2024-04-06

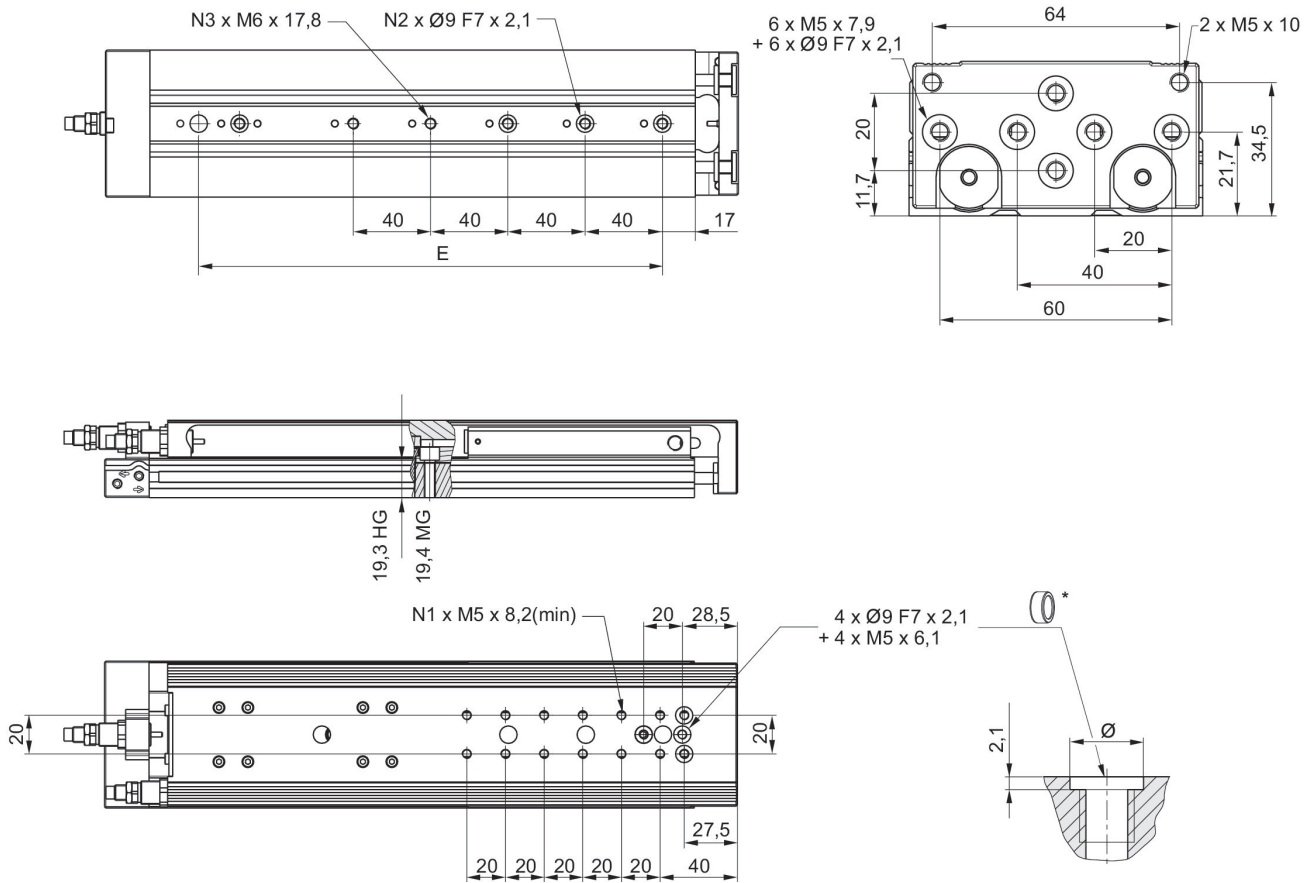

\* = centering rings

Part No.	Piston Ø	Stroke	E	N1	N2	N3
R412019175	16	125	200	12	4	5
R480643808	16	125	200	12	4	5
R412019188	16	125	200	12	4	5
R480640200	16	125	200	12	4	5
R412019176	16	150	240	12	4	5
R480643809	16	150	240	12	4	5
R412019189	16	150	240	12	4	5
R480640201	16	150	240	12	4	5

# Mini slide, Series MSC-HG-PM/PE

R480640206

AVENTICS  
Series  
MSC Guide  
cylinders

2024-04-06

## Dimensions

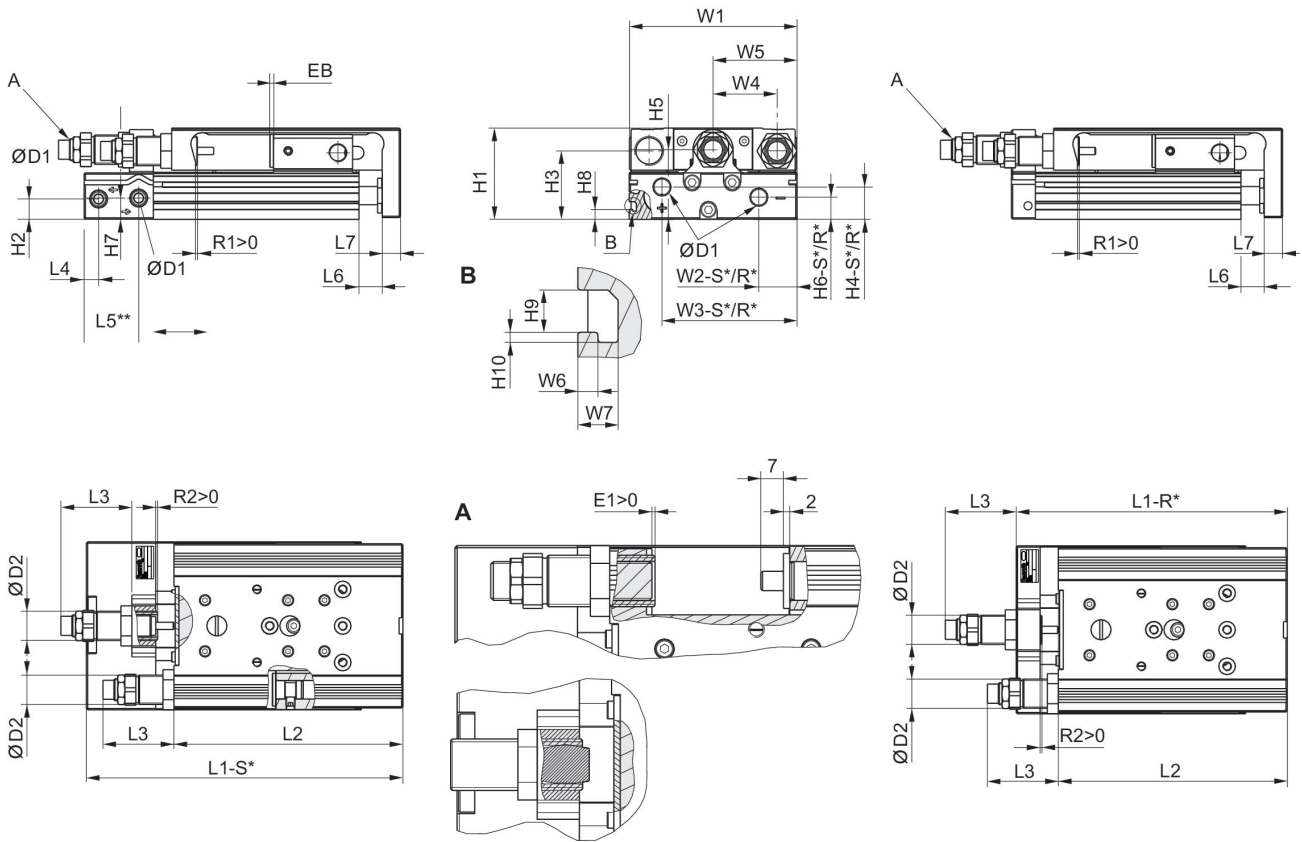

R\*: base with air connections only at the back  
S\*: base with air connections at the back and sides

## Dimensions

Piston Ø	Ø D1	Ø D2	H1	H2	H3	H4-R	H4-S	H5	H6-R
16	M5	M12x1	40	7.2	29	12.2	12.2	31	7.7
20	G 1/8	M16x1,5	50	11.2	37.5	17.3	17.3	38.2	11.7
25	G 1/8	M18x1,5	60	14.2	44	15.5	22.9	46.5	13.2

Piston Ø	H6-S	H7	H8	H9	H10	L3 1) max.	L3 2) max.	L4	L5 3)
16	7.7	11.2	-	-	-	12	47	6.5	17.7
20	12.2	11.7	5.5	4.2	1	15	57	8	30
25	21.7	16.2	6.9	5.2	1.5	15	62	9	31

Piston Ø	L6	L7	R2	W1	W2-R	W2-S	W3-R	W3-S	W4
16	2	10	3	76	31	31	60.5	60.5	30
20	2.1	10	3	92	10	21	74	74	35
25	2.1	12	3	112	11	14	92	92	44

Piston Ø	W5	W6	W7
16	W1/2	-	-
20	W1/2	2	4

# Mini slide, Series MSC-HG-PM/PE

R480640206

AVENTICS  
Series  
MSC Guide  
cylinders

2024-04-06

Piston Ø	W5	W6	W7
25	W1/2	2.5	4.8

## Stroke-dependent dimensions

Piston Ø	S=50 EB	S=80 EB	S=100 EB	S=125 EB	S=150 EB	S=200 EB	S=50 L1-R	S=80 L1-R	S=100 L1-R
16	2	2	2	2	2	–	126.8	172.8	192.8
20	2	2	2	2	2	2	137.9	182.9	202.9
25	2	2	2	2	2	2	149.1	195.1	215.1

Piston Ø	S=125 L1-R	S=150 L1-R	S=200 L1-R	S=50 L1-S	S=80 L1-S	S=100 L1-S	S=125 L1-S	S=150 L1-S	S=200 L1-S
16	281.3	306.3	–	137.7	183.7	203.7	292.2	317.2	–
20	287.4	327.4	402.4	162.8	207.8	227.8	312.3	352.3	427.3
25	292.1	332.1	407.1	172.8	218.8	238.8	315.8	355.8	430.8

Piston Ø	S=50 L2	S=80 L2	S=100 L2	S=125 L2	S=150 L2	S=200 L2	S=50 R1	S=80 R1	S=100 R1
16	115.4	161.4	181.4	269.9	294.9	–	8.7	8.7	8.7
20	125.5	170.5	190.5	275	315	390	12.4	12.4	12.4
25	134.5	180.5	200.5	277.5	317.5	392.5	10.5	11.5	11.5

Piston Ø	S=125 R1	S=150 R1	S=200 R1
16	8.7	8.7	–
20	12.4	12.4	12.4
25	11.5	11.5	11.5

# Mini slide, Series MSC-HG-PM/PE

R480640206

AVENTICS  
Series  
MSC Guide  
cylinders

2024-04-06

## Correction factor (a, d)

vertical

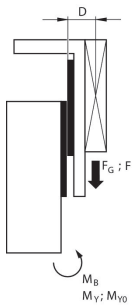

stat.	$M_{B0} = (F_G + F) \cdot D$
dyn.	$M_B = F_G \cdot D$

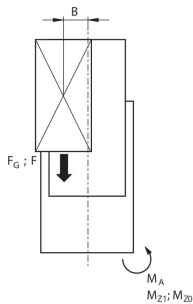

stat.	$M_{A0} = (F_G + F) \cdot B$
dyn.	$M_A = F_G \cdot B$

dyn.	$\frac{M_A}{M_1} + \frac{M_B}{M_2} \leq 1$
stat.	$\frac{M_{A0}}{M_{Z0}} + \frac{M_{B0}}{M_{Y0}} \leq 1$

$F = m \cdot a$   $F_G = m \cdot g$   $a = 1250 \cdot V^2 / H$

F = deceleration force [N]  $F_G$  = force due to weight [N] m = load mass [kg] a = deceleration [m/s<sup>2</sup>] g = gravitational acceleration 9,81 [m/s<sup>2</sup>] V = velocity [m/s] H = stroke length of shock absorber [mm]

## Correction factor (a, d)

horizontal

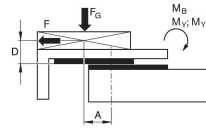

stat.	$M_{B0} = F_G \cdot A + F \cdot D$
dyn.	$M_B = F_G \cdot A$

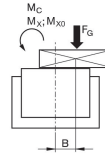

stat.	$M_{C0} = F_G \cdot B$
dyn.	$M_C = F_G \cdot B$

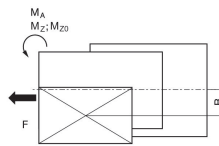

stat.	$M_{A0} = F \cdot B$
dyn.	$M_A = 0$

dyn.	$\frac{M_A}{M_1} + \frac{M_B}{M_2} + \frac{M_C}{M_3} \leq 1$
stat.	$\frac{M_{A0}}{M_{Z0}} + \frac{M_{B0}}{M_{Y0}} + \frac{M_{C0}}{M_{X0}} \leq 1$

$F = m \cdot a$   $F_G = m \cdot g$   $a = 1250 \cdot V^2 / H$

F = deceleration force [N]  $F_G$  = force due to weight [N] m = load mass [kg] a = deceleration [m/s<sup>2</sup>] g = gravitational acceleration 9,81 [m/s<sup>2</sup>] V = velocity [m/s] H = stroke length of shock absorber [mm]

## Correction factor (a, d)

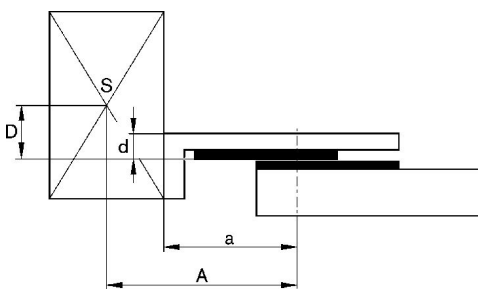

## Maximum moving mass

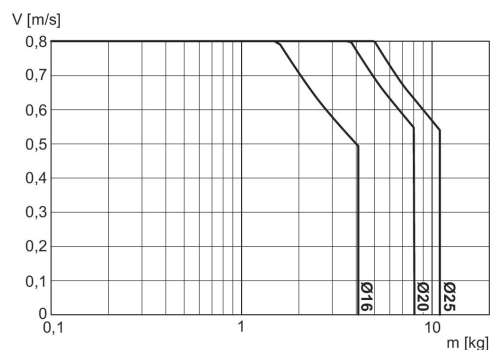

V = velocity [m/s]  
m = mass



# Mini slide, Series MSC-HG-PM/PE

R480640206

AVENTICS  
Series  
MSC Guide  
cylinders  
2024-04-06

Correction factor for required speed:  
retracting and extending, horizontal

Correction factor for required speed:  
extending, vertical, downwards

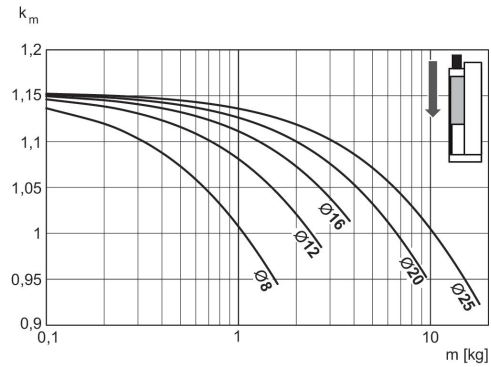
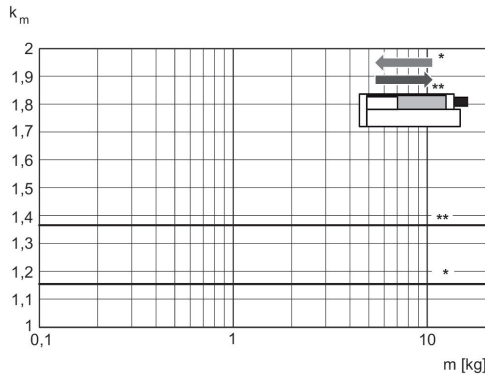

\* retracting  
\*\* extracting  
 $V = s/1000 \cdot t \cdot km$   
V = velocity [m/s]  
S = stroke

$V = s/1000 \cdot t \cdot km$   
V = velocity [m/s]  
S = stroke [mm]  
t = time [s] for one stroke  
m = mass

Correction factor for required speed:  
retracting, vertical, downwards

Correction factor for required speed:  
retracting, vertical, upwards

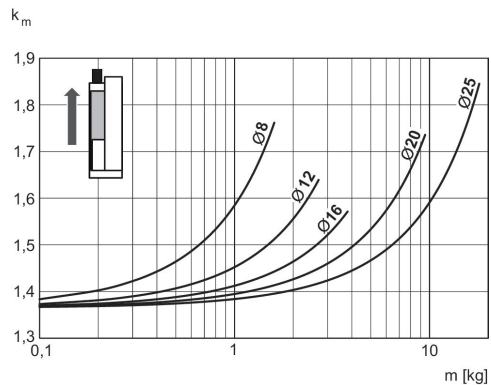
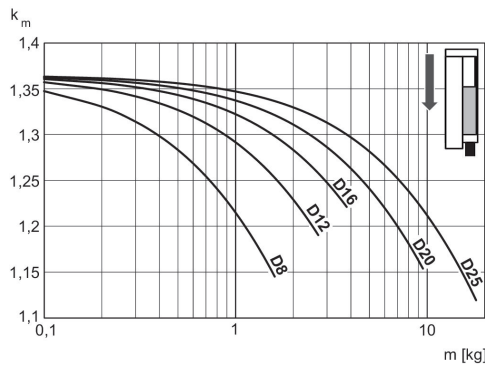

$V = s/1000 \cdot t \cdot km$   
V = velocity [m/s]  
S = stroke [mm]  
t = time [s] for one stroke  
m = mass

$V = s/1000 \cdot t \cdot km$   
V = velocity [m/s]  
S = stroke [mm]  
t = time [s] for one stroke  
m = mass

# Mini slide, Series MSC-HG-PM/PE

R480640206

AVENTICS  
Series  
MSC Guide  
cylinders

2024-04-06

Correction factor for required speed: **Max. extracting speed**  
extending, vertical, upwards

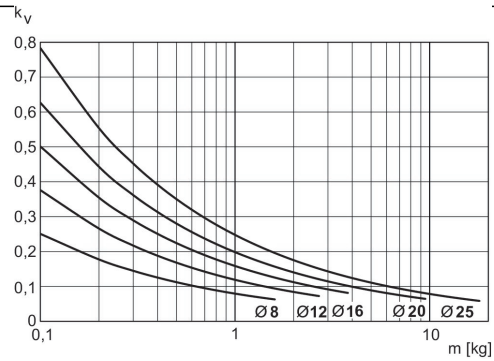
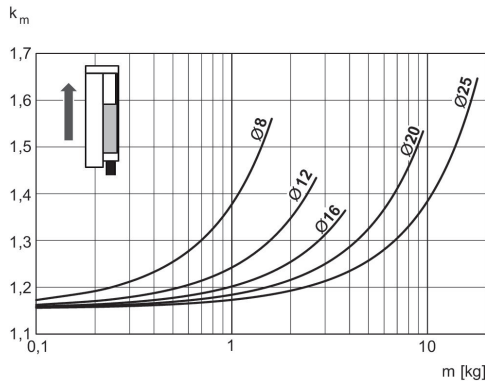

$V = s/1000 \cdot t \cdot k_m$   
V = velocity [m/s]  
S = stroke [mm]  
t = time [s] for one stroke  
m = mass

$V = \sqrt{s \cdot k_v}$   
V = velocity [m/s]  
S = stroke [mm]  
m = mass

## Load capacity

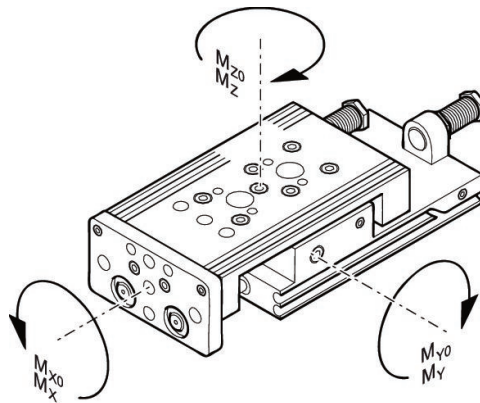

M = max. permissible torque

## Correction factor (a)

Piston Ø	S	a [mm] 1)	d [mm] 2)	Mx0 Static moment M [Nm]	My0 Static moment M [Nm]	Mz0 Static moment M [Nm]	Mx Dynamic moment M [Nm]	My Dynamic moment M [Nm]	Mz Dynamic moment M [Nm]
16	50	85.5	15	38	29	29	7	7,6	7,6
20	50	90.5	20	93	65	65	10	13.3	13.3
25	50	96.5	24	100	90	90	15.3	13	13

# Mini slide, Series MSC-HG-PM/PE

R480640206

AVENTICS  
Series  
MSC Guide  
cylinders

2024-04-06

## Overview drawing

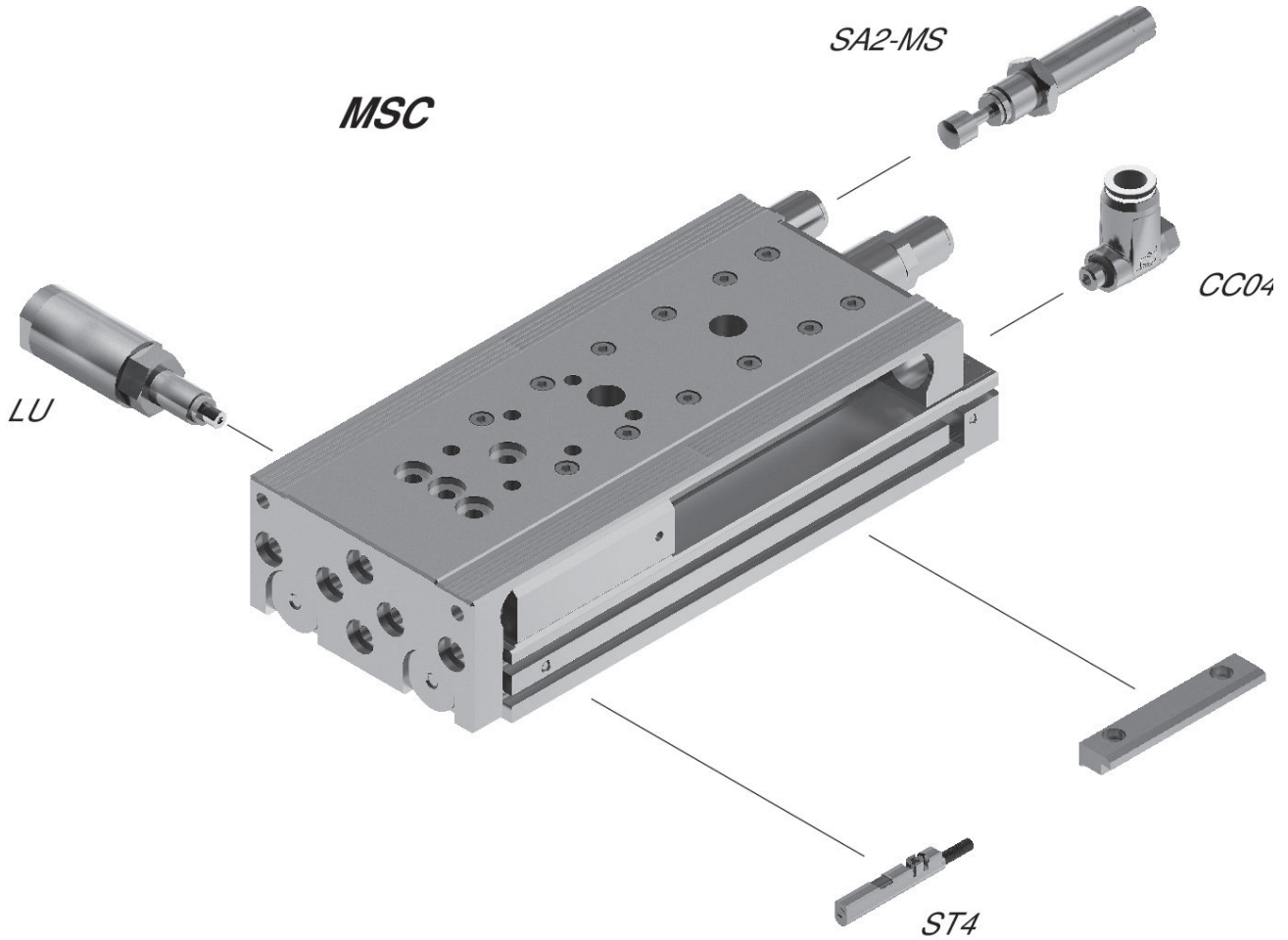

NOTE: This overview drawing is only for orientation to indicate where the various accessory parts can be fastened to the cylinder. The illustration has been simplified for this purpose. It is thus not possible to derive the dimensions from this overview.

## Weight of moving parts [kg]

Piston Ø	S=10	S=20	S=30	S=40	S=50	S=80	S=100	S=125	S=150
16	0.375	0.375	0.375	0.4	0.45	0.615	0.65	0.725	0.765
20	0.655	0.655	0.655	0.69	0.765	0.985	1.035	1.2	1.29
25	1	1	1	1.1	1.225	1.45	1.625	1.885	2.085

Piston Ø	S=200
16	-
20	1.54
25	2.445

S = stroke