

- Ø 32 mm ... 320 mm

## AVENTICS Modular scraper systems and front lube unit

The AVENTICS Modular scraper system and front lube unit offer more flexibility by implementing a different scraper model with the same cylinder if yours needs changing. They are available separately as spare parts with fully installed seals and bushings and can be exchanged at any time, quickly and easily, without removing the cylinder.



## Technical data

Industry

Industrial

For series

PRA  
TRB  
CCL-IS

Scraper

Chemical-resistant scraper

Application area

Textile industry  
Food industry  
Chemical industry  
Sugar production

Piston Ø

40 mm

Min. working pressure

1.5 bar

Max. working pressure

10 bar

Min. ambient temperature

-20 °C

Max. ambient temperature

80 °C

Medium

Compressed air

Min. oil content of compressed air

0 mg/m<sup>3</sup>

Max. oil content of compressed air

5 mg/m<sup>3</sup>

## Material

Housing material

Aluminum

# Modular scraper system

0496401204

Series MS

2023-12-20

Surface

anodized

Piston rod seal

Acrylonitrile butadiene rubber

Scraper

Polytetrafluorethylene

Part No.

0496401204

## Dimensions

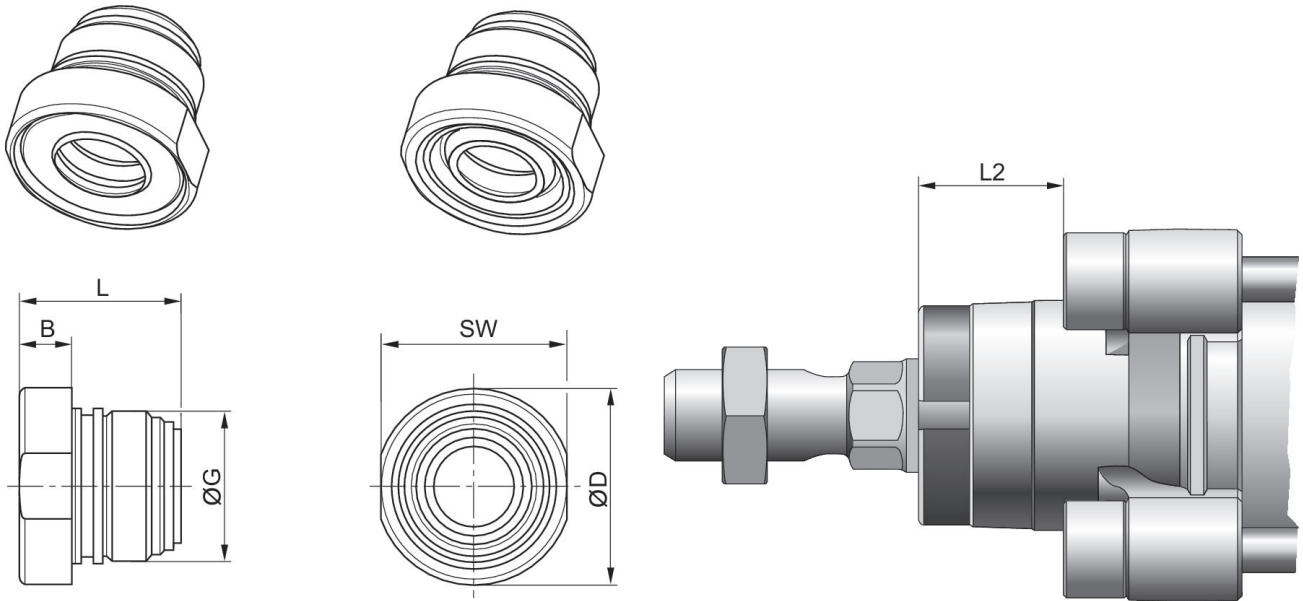

Piston Ø	B	ØD	G	L	L2	SW
32	6.7	24.5	M22x1	23	16.25	23
40	9.2	34	M26x1,5	28.1	18.25	32