

# Condensate separator, Series MU1

R412010690

## General series information Series MU1

- The AVENTICS Series MU1 components are ideal for applications in harsh environments. They offer large thread connections to guarantee a high compressed air flow rate and provide reliable filtration, regulation and lubrication.

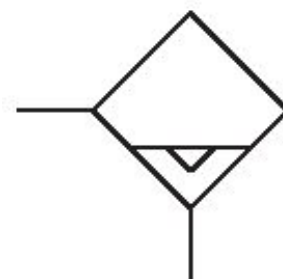

## Technical data

Industry

Industrial

Parts

Condensate separator

Mounting orientation

vertical

Filter reservoir volume

49 cm<sup>3</sup>

Condensate drain

fully automatic, closed without pressure

Compressed air connection

G 1/2

Working pressure min.

2 bar

Working pressure max

16 bar

Min. ambient temperature

0 °C

Max. ambient temperature

50 °C

Medium

Compressed air  
Neutral gases

Weight 0.185 kg

### Material

Material reservoir	Polycarbonate
Material protective guard	Polyamide
Seal material	Nitrile butadiene rubber
Part No.	R412010690

### Technical information

To discharge condensate and oil from the compressed air network  
Ideally installed at the lowest point of the compressed air network

### Dimensions

Fig. 1

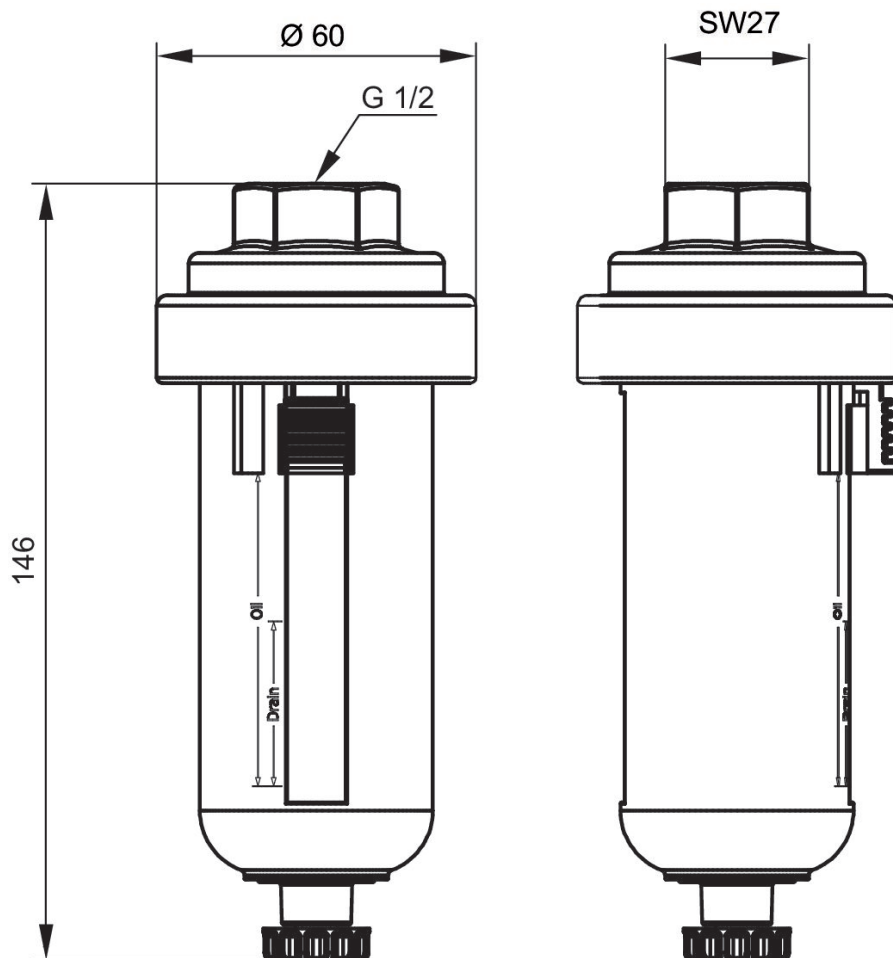

Dimensions  
Fig. 2

