

Condensate separator, Series MU1

R412010689

General series information Series MU1

- The AVENTICS Series MU1 components are ideal for applications in harsh environments. They offer large thread connections to guarantee a high compressed air flow rate and provide reliable filtration, regulation and lubrication.

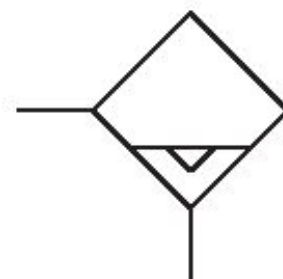

Technical data

Industry

Industrial

Parts

Condensate separator

Mounting orientation

vertical

Filter reservoir volume

49 cm³

Condensate drain

fully automatic, open without pressure

Compressed air connection

G 1/2

Working pressure min.

2 bar

Working pressure max

16 bar

Min. ambient temperature

0 °C

Max. ambient temperature

50 °C

Medium

Compressed air
Neutral gases

Weight 0.185 kg

Material

Material reservoir	Polycarbonate
Material protective guard	Polyamide
Seal material	Nitrile butadiene rubber
Part No.	R412010689

Technical information

To discharge condensate and oil from the compressed air network
Ideally installed at the lowest point of the compressed air network

Dimensions

Fig. 1

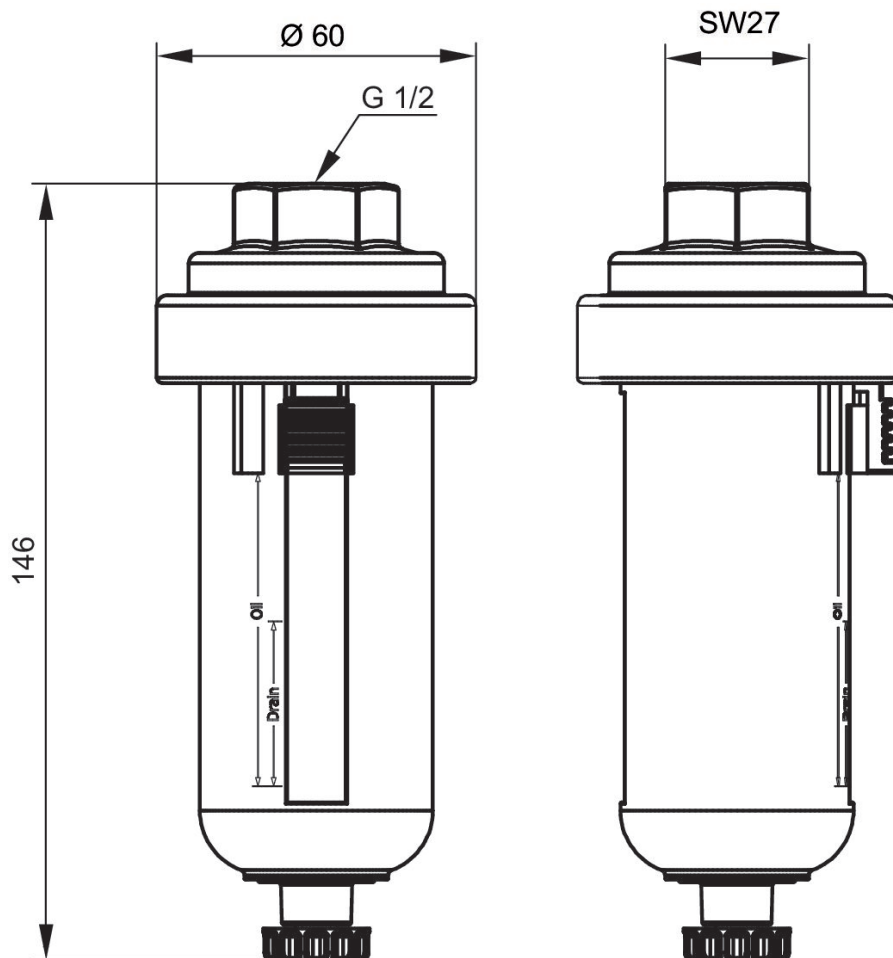

Dimensions
Fig. 2

