

AVENTICS Series NCT Non-contact transport system

AVENTICS Series NCT non-contact transport systems make for a unique gripping experience: The floating suction pads in the NCT Series are masterful in sensitively handling delicate surfaces and difficult-to-grasp materials in a virtually non-contact and extremely gentle process. Handling with NCT is even possible with a large degree of perforation, contaminated, wet, and dusty surfaces, or soft materials.

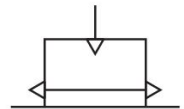

Technical data

Industry	Industrial
Compressed air connection	G 1/8
Lifting force at [[5] bar]	13 N
Diameter	60 mm
Type	Bernoulli principle
Air consumption at [[5] bar]	150 l/min
Min. working pressure	1 bar
Max. working pressure	6 bar
Min. ambient temperature	5 °C
Max. ambient temperature	60 °C
Medium	Compressed air
Min. oil content of compressed air	0 mg/m ³
Max. particle size	40 µm
Housing material	Aluminum
Surface housing	anodized
Material stop	High-temperature material HT1
Nozzle material	Stainless Steel
Material blanking screw	Brass
Seal material	Nitrile butadiene rubber

Non-contact transport system, Series NCT-AL

R412010375

series NCT

2024-01-22

Weight

0.1195 kg

Part No.

R412010375

Non-contact transport system, Series NCT-AL

series NCT

R412010375

2024-01-22

Dimensions

Ø 100

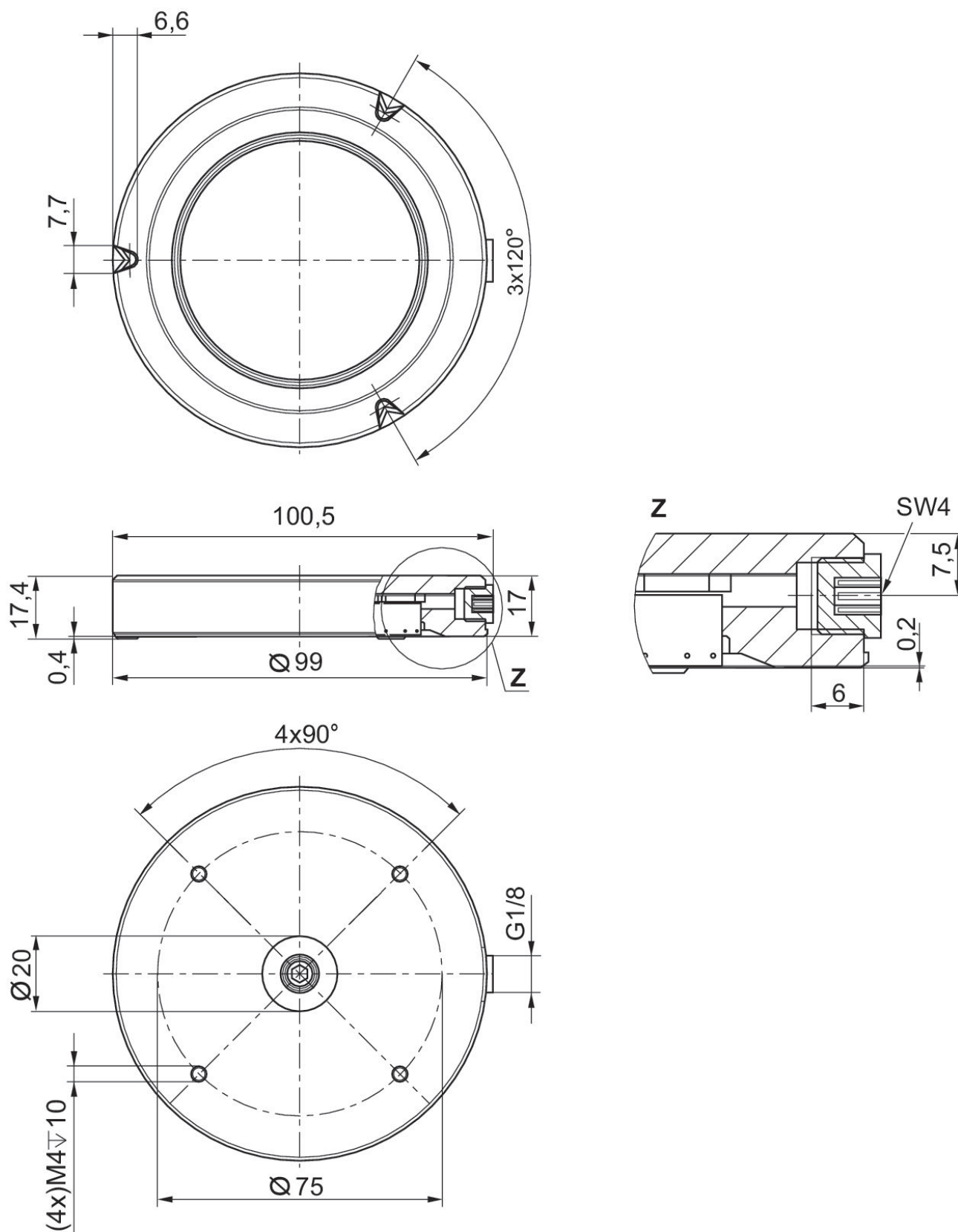

Non-contact transport system, Series NCT-AL

series NCT

R412010375

2024-01-22

Dimensions

Ø 60

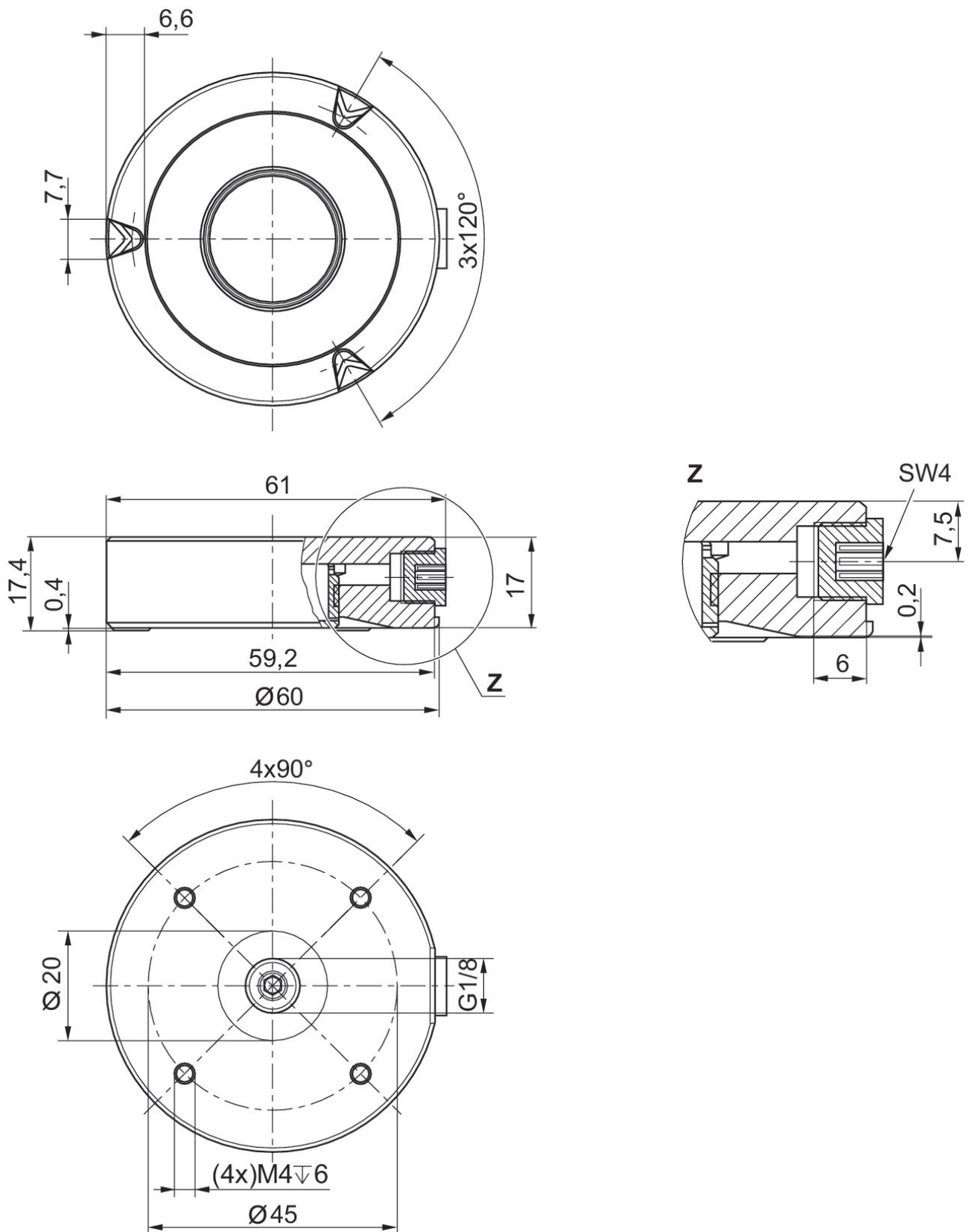

Non-contact transport system, Series NCT-AL

series NCT

R412010375

2024-01-22

Dimensions

Ø 40

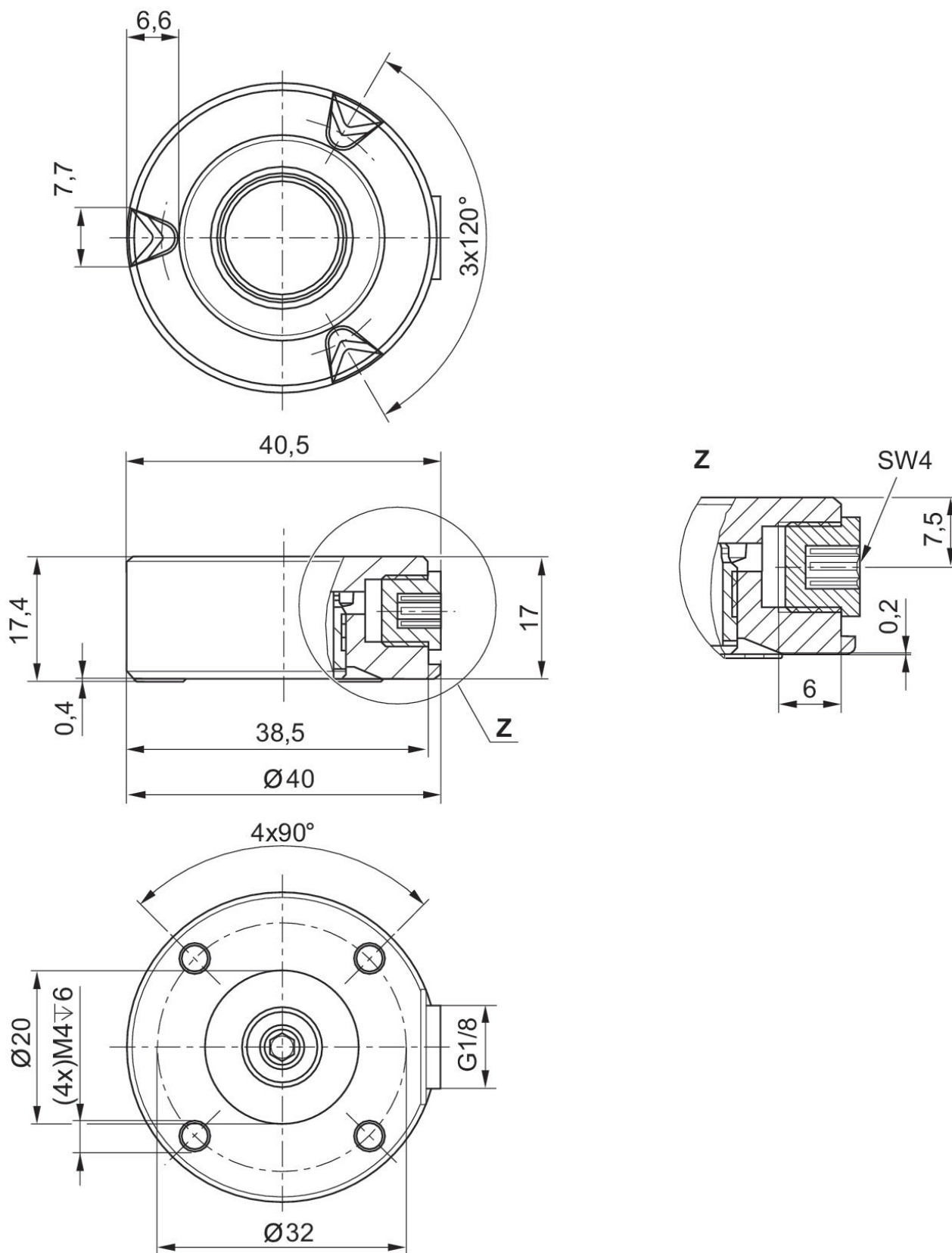

Non-contact transport system, Series NCT-AL

series NCT

R412010375

2024-01-22

Dimensions

Ø 30

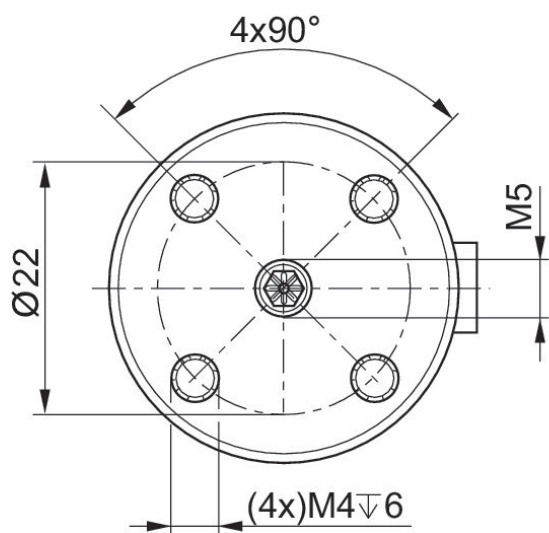
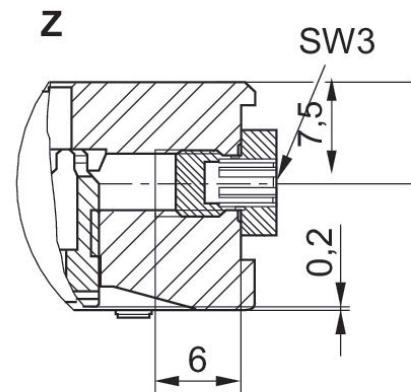
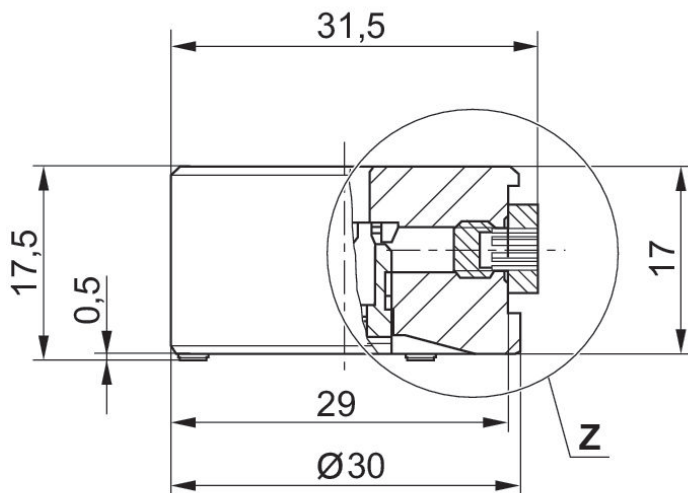
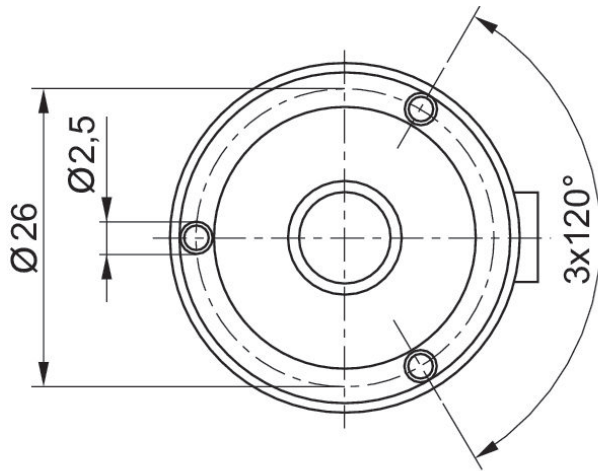

Principle of operation

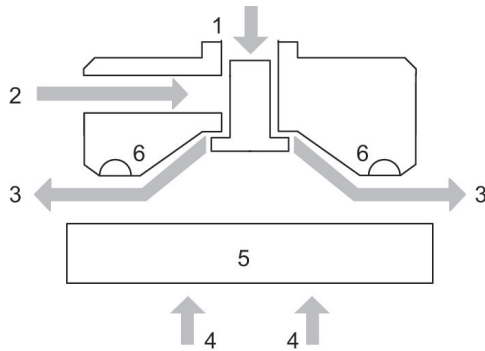

1) Compressed air connection 2) Alternative compressed air connection 3) Air flow 4) Lifting force 5) Object 6) Stop

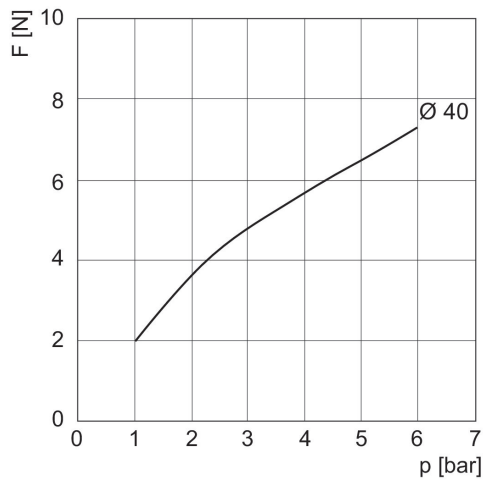
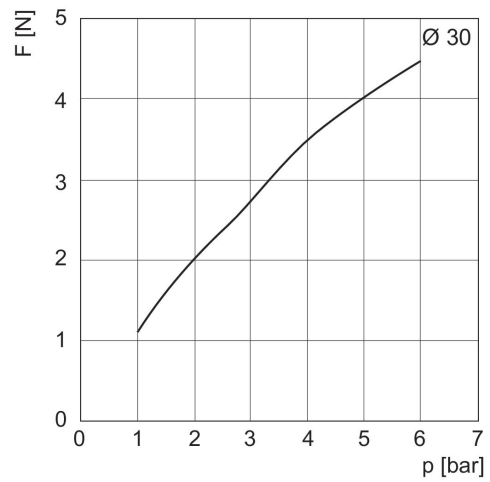

Air consumption Q depending on working pressure p

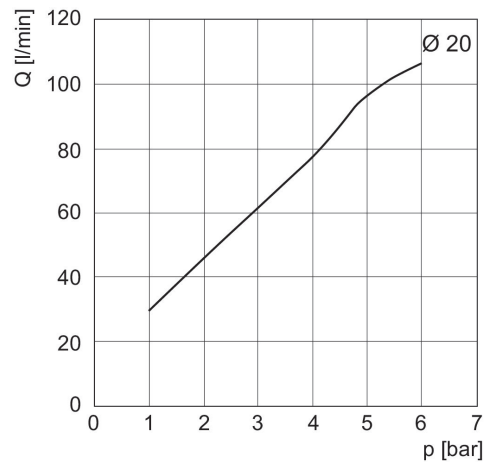

Lifting force F dependent on working pressure p

