

## AVENTICS Series NL1 Air Preparation Units

The AVENTICS Series NL maintenance units are suitable for all areas: as individual components or as assembled maintenance units, for centralized or decentralized compressed air preparation, in compact or powerful versions, for use in high or low temperatures. This line offers a complete, customizable compressed air preparation technology. It includes an option to combine every component in the Series to achieve the desired function, making it possible to adjust the components precisely to the application requirements.



### Technical data

Industry	Industrial
Parts	Filter
Reservoir	reservoir, polycarbonate, without protective guard
Port	G 1/8
Filter porosity	5 µm
Nominal flow Qn	1000 l/min
Condensate drain	fully automatic, open without pressure
Min. working pressure	1.5 bar
Max. working pressure	16 bar
Min. ambient temperature	-10 °C
Max. ambient temperature	60 °C
Medium	Compressed air Neutral gases
Max. achievable compressed air class acc. to ISO 8573-1:2010	6 : 7 : -
Filter reservoir volume	16 cm <sup>3</sup>
Filter element	exchangeable
Weight	0.263 kg
Mounting orientation	vertical
Type	Can be assembled into blocks

## Material

Housing material	Die cast zinc
Seal material	Acrylonitrile butadiene rubber
Material reservoir	Polycarbonate
Material filter insert	Cellpor
Part No.	0821303712

## Technical information

The pressure dew point must be at least 15 °C less than ambient and medium temperature and may not exceed 3 °C.

Note: Polycarbonate reservoirs are susceptible to solvents, supplementary information can be found at "Customer information".

A change in the flow direction (from air supply on the left to air supply on the right) occurs by rotating installation by 180° about the vertical axis. Please see the operating instructions for further details.

Nominal flow  $Q_n$  with secondary pressure  $p_2 = 6$  bar at  $\Delta p = 1$  bar

Also suitable for separation of fluid oil or water due to the design.

Metal protective guard can be retrofitted for all polycarbonate reservoirs

0821303712

## Dimensions

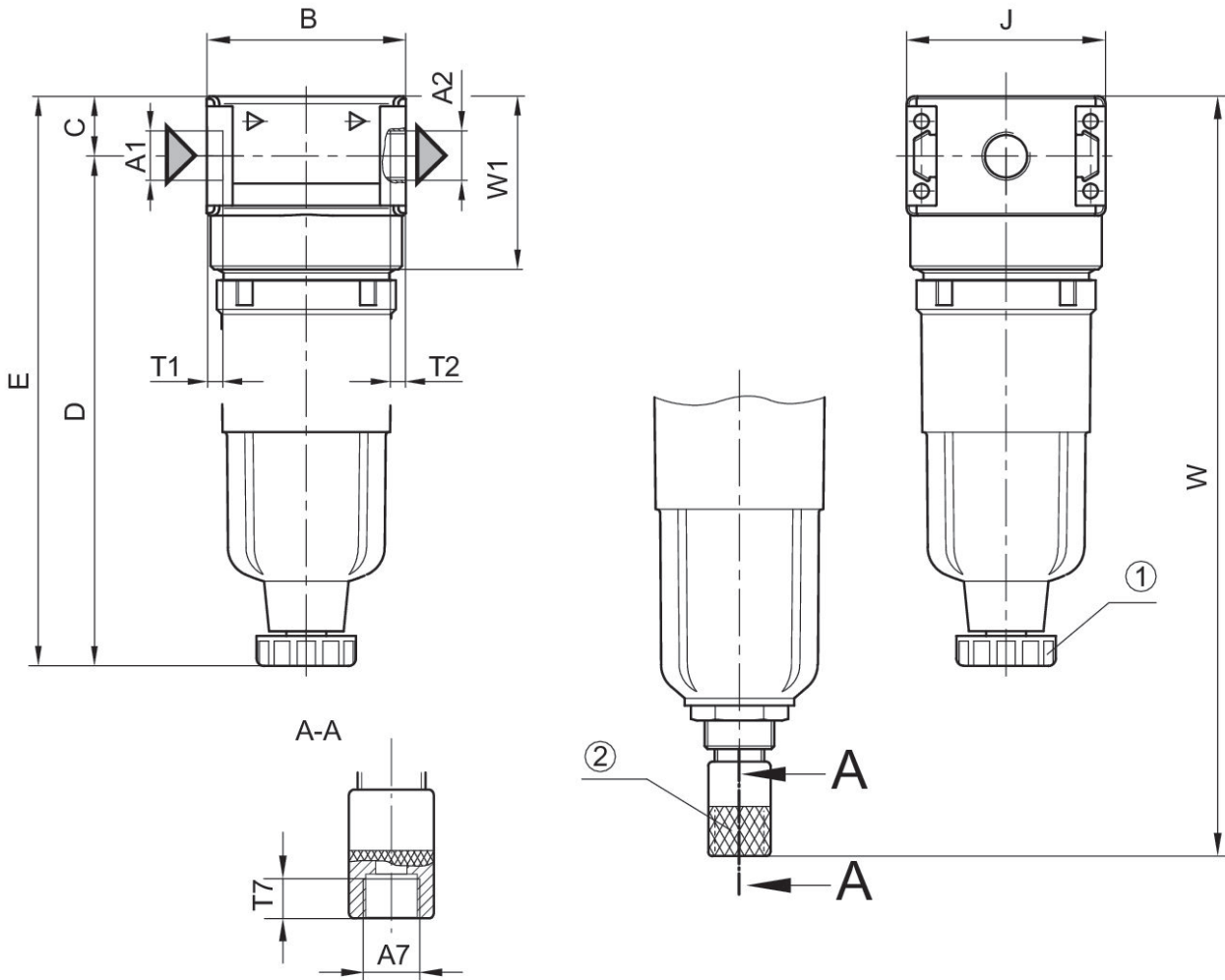

A1 = input A2 = output

1) Semi-automatic condensate drain 2) fully automatic condensate drain

## Dimensions in mm

Part No.	A1	A2	A7	B	C	D	E	J	T1
0821303710	G 1/8	G 1/8	G 1/8	40	12.3	102.5	114.8	40	8
0821303711	G 1/8	G 1/8	G 1/8	40	12.3	-	114	40	8
0821303712	G 1/8	G 1/8	G 1/8	40	12.3	-	-	40	8
0821303713	G 1/4	G 1/4	G 1/8	40	12.3	102.5	114.8	40	8
0821303714	G 1/4	G 1/4	G 1/8	40	12.3	-	114	40	8
0821303715	G 1/4	G 1/4	G 1/8	40	12.3	-	-	40	8

Part No.	T2	T7	W	W1
0821303710	8	8.5	-	35.1
0821303711	8	8.5	-	35.1
0821303712	8	8.5	154	35.1

# Filter, Series NL1-FLS

2024-04-23

0821303712

Part No.	T2	T7	W	W1
0821303713	8	8.5	-	35.1
0821303714	8	8.5	-	35.1
0821303715	8	8.5	154	35.1

Flow rate characteristic,  $p_2 = 0,05 - 7$  bar

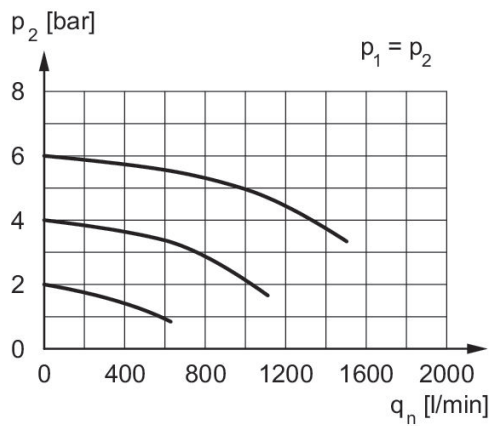

$p_2$  = secondary pressure  $q_n$  = nominal flow