

AVENTICS Series NL2 Air Preparation Units

The AVENTICS Series NL maintenance units are suitable for all areas: as individual components or as assembled maintenance units, for centralized or decentralized compressed air preparation, in compact or powerful versions, for use in high or low temperatures. This line offers a complete, customizable compressed air preparation technology. It includes an option to combine every component in the Series to achieve the desired function, making it possible to adjust the components precisely to the application requirements.

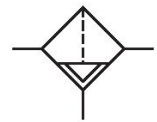

Technical data

Industry	Industrial
Parts	Pre-filter
Reservoir	Reservoir polycarbonate
Port	G 1/4
Filter porosity	0.3 µm
Nominal flow Qn	380 l/min
Condensate drain	fully automatic, open without pressure
Min. working pressure	2 bar
Max. working pressure	16 bar
Min. ambient temperature	-10 °C
Max. ambient temperature	60 °C
Medium	Compressed air Neutral gases
Max. achievable compressed air class acc. to ISO 8573-1:2010	2 : - : 3
Filter reservoir volume	10 cm ³
Filter element	exchangeable
Recommended pre-filtering	5 µm
Weight	0.45 kg
Mounting orientation	vertical
Type	Can be assembled into blocks
Material	
Housing material	Die cast zinc

0821303309

Material front plate	Acrylonitrile butadiene styrene
Seal material	Acrylonitrile butadiene rubber
Material reservoir	Polycarbonate
Material filter insert	Impregnated paper
Part No.	0821303309

Technical information

The pressure dew point must be at least 15 °C less than ambient and medium temperature and may not exceed 3 °C.

A change in the flow direction (from air supply on the left to air supply on the right) occurs by rotating installation by 180° about the vertical axis. Please see the operating instructions for further details.

Note: Polycarbonate reservoirs are susceptible to solvents, supplementary information can be found at "Customer information".

Nominal flow Q_n with secondary pressure $p_2 = 6$ bar at $\Delta p = 0,1$ bar

Dimensions

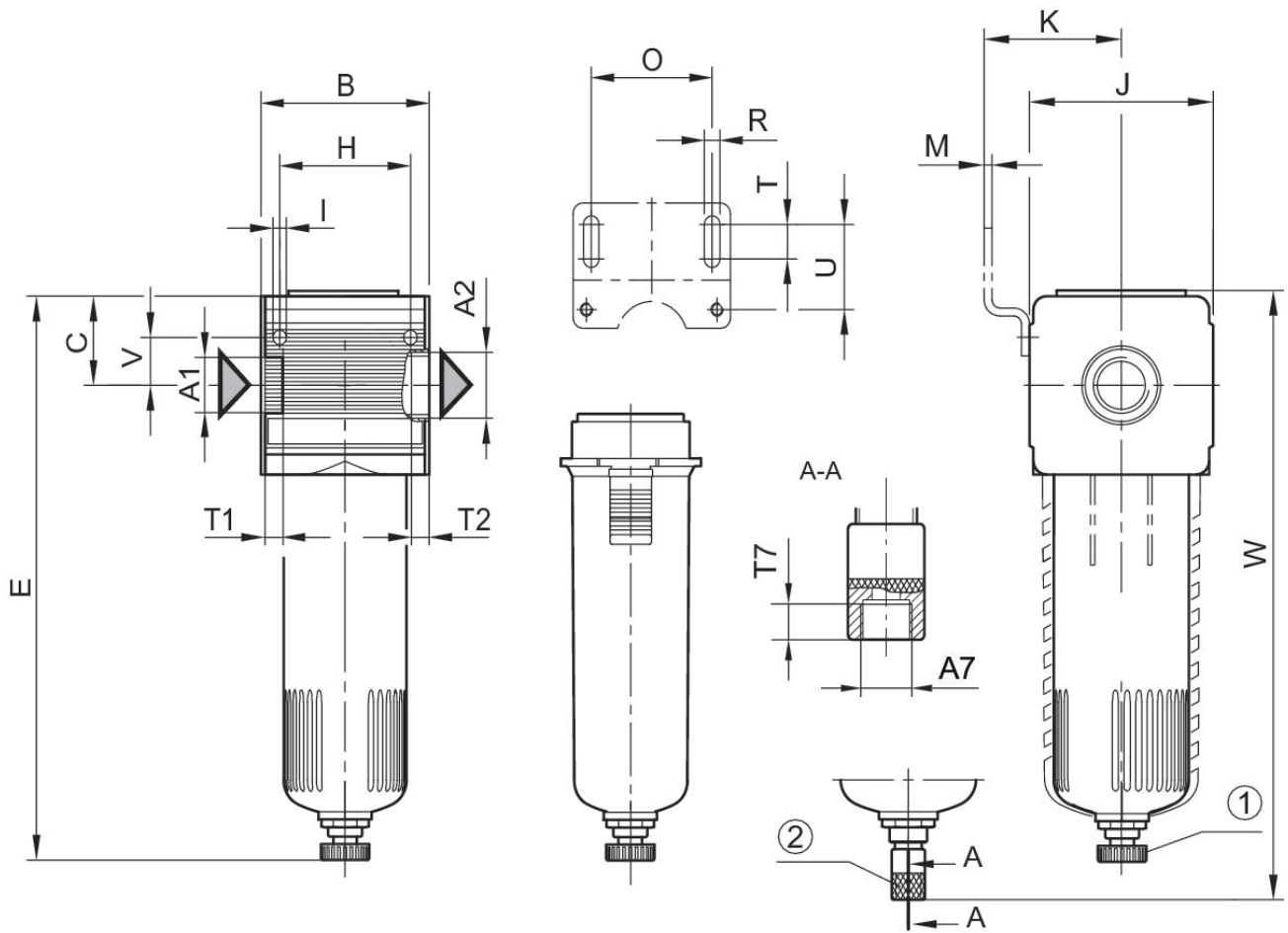

A1 = input A2 = output

A7 = condensate drain

1) Semi-automatic condensate drain 2) fully automatic condensate drain

Dimensions in mm

Part No.	A1	A2	A7	B	C	E	H	I	J
0821303308	G 1/4	G 1/4	G 1/8	48	27.5	152	36	4.4	47
0821303309	G 1/4	G 1/4	G 1/8	48	27.5	—	36	4.4	47
R412010785	G 1/4	G 1/4	G 1/8	48	27.5	—	36	4.4	47

Part No.	K	M	O	R	T	T1	T2	T7	U
0821303308	43.5	3	38	5.4	8	9.5	9.5	8.5	27.5
0821303309	43.5	3	38	5.4	8	9.5	9.5	8.5	27.5
R412010785	43.5	3	38	5.4	8	9.5	9.5	8.5	27.5

Part No.	V	W
0821303308	12.3	—
0821303309	12.3	168
R412010785	12.3	168

Flow rate characteristic, $p_2 = 0,05 - 7$ bar

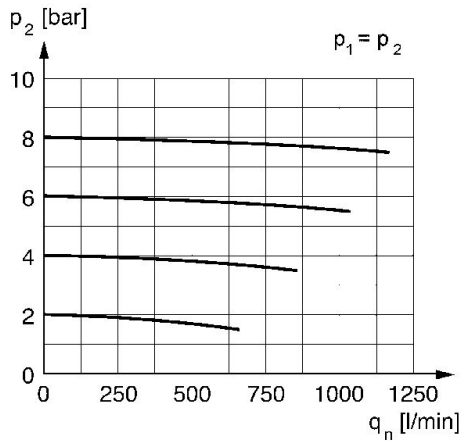

p_2 = secondary pressure q_n = nominal flow