

AVENTICS Series NL2 Air Preparation Units

The AVENTICS Series NL maintenance units are suitable for all areas: as individual components or as assembled maintenance units, for centralized or decentralized compressed air preparation, in compact or powerful versions, for use in high or low temperatures. This line offers a complete, customizable compressed air preparation technology. It includes an option to combine every component in the Series to achieve the desired function, making it possible to adjust the components precisely to the application requirements.

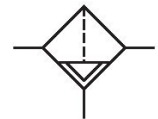

Technical data

Industry	Industrial
Parts	Filter
Reservoir	reservoir, polycarbonate, without protective guard
Port	G 3/8
Filter porosity	5 µm
Nominal flow Qn	2100 l/min
Condensate drain	semi-automatic, open without pressure
Min. working pressure	2 bar
Max. working pressure	16 bar
Min. ambient temperature	-10 °C
Max. ambient temperature	60 °C
Medium	Compressed air Neutral gases
Max. achievable compressed air class acc. to ISO 8573-1:2010	6 : 7 : -
Filter reservoir volume	25 cm ³
Filter element	exchangeable
Weight	0.275 kg
Mounting orientation	vertical
Type	Can be assembled into blocks

Material

Housing material	Die cast zinc
Material front plate	Acrylonitrile butadiene styrene
Seal material	Acrylonitrile butadiene rubber
Material reservoir	Polycarbonate
Material filter insert	Cellpor
Part No.	0821303440

Technical information

The pressure dew point must be at least 15 °C less than ambient and medium temperature and may not exceed 3 °C.

A change in the flow direction (from air supply on the left to air supply on the right) occurs by rotating installation by 180° about the vertical axis. Please see the operating instructions for further details.

Note: Polycarbonate reservoirs are susceptible to solvents, supplementary information can be found at "Customer information".

Also suitable for separation of fluid oil or water due to the design.

Nominal flow Q_n with secondary pressure $p_2 = 6$ bar at $\Delta p = 1$ bar

Dimensions

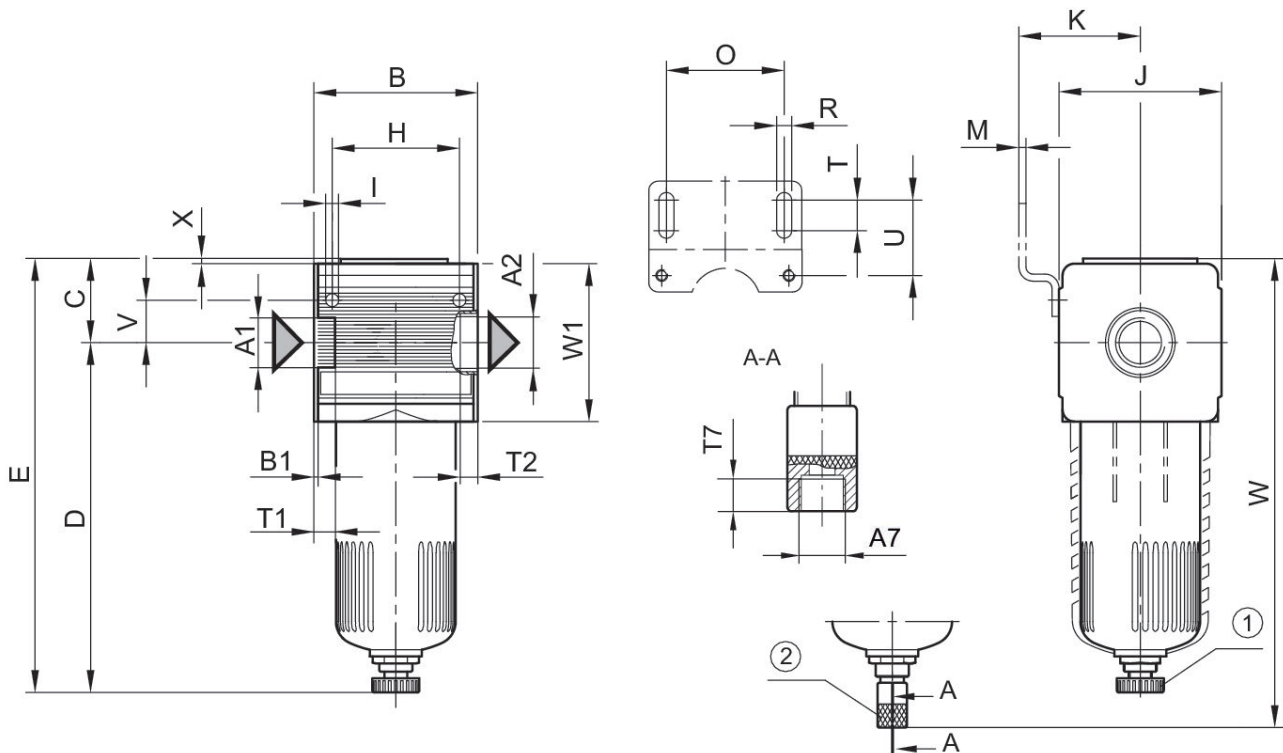

A1 = input A2 = output
A7 = condensate drain

1) Semi-automatic condensate drain 2) fully automatic condensate drain

Dimensions in mm

Part No.	A1	A2	A7	B	B1	C	D	E	H
0821303400	G 1/4	G 1/4	G 1/8	48	1.5	27.5	124.5	152	36
0821303401	G 1/4	G 1/4	G 1/8	48	1.5	27.5	124.5	152	36
0821303402	G 1/4	G 1/4	G 1/8	48	1.5	27.5	124.5	152	36
0821303403	G 1/4	G 1/4	G 1/8	48	1.5	27.5	124.5	152	36
0821303404	G 1/4	G 1/4	G 1/8	48	1.5	27.5	124.5	152	36
0821303405	G 1/4	G 1/4	G 1/8	48	1.5	27.5	124.5	152	36
0821303440	G 3/8	G 3/8	G 1/8	48	1.5	27.5	124.5	152	36
0821303441	G 3/8	G 3/8	G 1/8	48	1.5	27.5	124.5	152	36
0821303442	G 3/8	G 3/8	G 1/8	48	1.5	27.5	124.5	152	36
0821303443	G 3/8	G 3/8	G 1/8	48	1.5	27.5	124.5	152	36
0821303444	G 3/8	G 3/8	G 1/8	48	1.5	27.5	124.5	152	36
0821303445	G 3/8	G 3/8	G 1/8	48	1.5	27.5	124.5	152	36

Part No.	I	J	K	M	O	R	T	T1	T2
0821303400	4.4	47	43.5	3	38	5.4	8	9.5	9.5
0821303401	4.4	47	43.5	3	38	5.4	8	9.5	9.5

Filter, Series NL2-FLS

2024-04-23

0821303440

Part No.	I	J	K	M	O	R	T	T1	T2
0821303402	4.4	47	43.5	3	38	5.4	8	9.5	9.5
0821303403	4.4	47	43.5	3	38	5.4	8	9.5	9.5
0821303404	4.4	47	43.5	3	38	5.4	8	9.5	9.5
0821303405	4.4	47	43.5	3	38	5.4	8	9.5	9.5
0821303440	4.4	47	43.5	3	38	5.4	8	9.5	9.5
0821303441	4.4	47	43.5	3	38	5.4	8	9.5	9.5
0821303442	4.4	47	43.5	3	38	5.4	8	9.5	9.5
0821303443	4.4	47	43.5	3	38	5.4	8	9.5	9.5
0821303444	4.4	47	43.5	3	38	5.4	8	9.5	9.5
0821303445	4.4	47	43.5	3	38	5.4	8	9.5	9.5

Part No.	T7	U	V	W	W1	X
0821303400	8.5	27.5	12.3	165	156	1.5
0821303401	8.5	27.5	12.3	165	156	1.5
0821303402	8.5	27.5	12.3	165	156	1.5
0821303403	8.5	27.5	12.3	165	156	1.5
0821303404	8.5	27.5	12.3	165	156	1.5
0821303405	8.5	27.5	12.3	165	156	1.5
0821303440	8.5	27.5	12.3	165	156	1.5
0821303441	8.5	27.5	12.3	165	156	1.5
0821303442	8.5	27.5	12.3	165	156	1.5
0821303443	8.5	27.5	12.3	165	156	1.5
0821303444	8.5	27.5	12.3	165	156	1.5
0821303445	8.5	27.5	12.3	165	156	1.5

Flow rate characteristic, $p_2 = 0,05 - 7$ bar

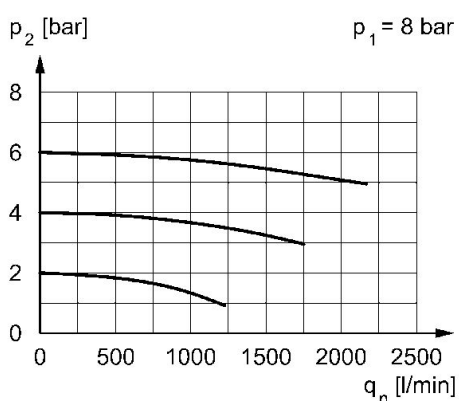

p_1 = Working pressure p_2 = Secondary pressure q_n = Nominal flow