

AVENTICS Series NL2 Air Preparation Units

The AVENTICS Series NL maintenance units are suitable for all areas: as individual components or as assembled maintenance units, for centralized or decentralized compressed air preparation, in compact or powerful versions, for use in high or low temperatures. This line offers a complete, customizable compressed air preparation technology. It includes an option to combine every component in the Series to achieve the desired function, making it possible to adjust the components precisely to the application requirements.

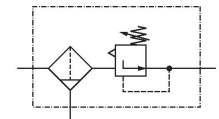

Technical data

Industry	Industrial
Parts	Filter pressure regulator
Reservoir	reservoir, polycarbonate, without protective guard
Port	G 1/4
Nominal flow Qn	1650 l/min
Filter porosity	5 µm
Condensate drain	semi-automatic, open without pressure
Pressure gauge	without pressure gauge
Min. working pressure	2 bar
Max. working pressure	16 bar
Min. ambient temperature	-10 °C
Max. ambient temperature	60 °C
Min. regulation range	0.5 bar
Max. regulation range	10 bar
Type	1-part
Type	Can be assembled into blocks
Pressure supply	single
Mounting orientation	vertical
Regulator type	Diaphragm-type pressure regulator

Regulator function	with relieving air exhaust
Filter element	exchangeable
Filter reservoir volume	25 cm ³
Max. achievable compressed air class acc. to ISO 8573-1:2010	6 : 7 : -
Medium	Compressed air Neutral gases
Weight	0.542 kg

Material

Housing material	Die cast zinc
Seal material	Acrylonitrile butadiene rubber
Material front plate	Acrylonitrile butadiene styrene
Material threaded bushing	Die cast zinc
Material reservoir	Polycarbonate
Material filter insert	Polyethylene
Part No.	0821300316

Technical information

The pressure dew point must be at least 15 °C less than ambient and medium temperature and may not exceed 3 °C.

Nominal flow Q_n with secondary pressure $p_2 = 6$ bar at $\Delta p = 1$ bar

Note: Polycarbonate reservoirs are susceptible to solvents, supplementary information can be found at "Customer information".

A change in the flow direction (from air supply on the left to air supply on the right) occurs by rotating installation by 180° about the vertical axis. Please see the operating instructions for further details.

Also suitable for separation of fluid oil or water due to the design.

The rear pressure gauge connection on the pressure regulator is closed with a blanking plug, the front connection is open. Depending on the customer application, a second blanking plug may be necessary. Please order separately (see accessories).

Order pressure gauge separately

Dimensions

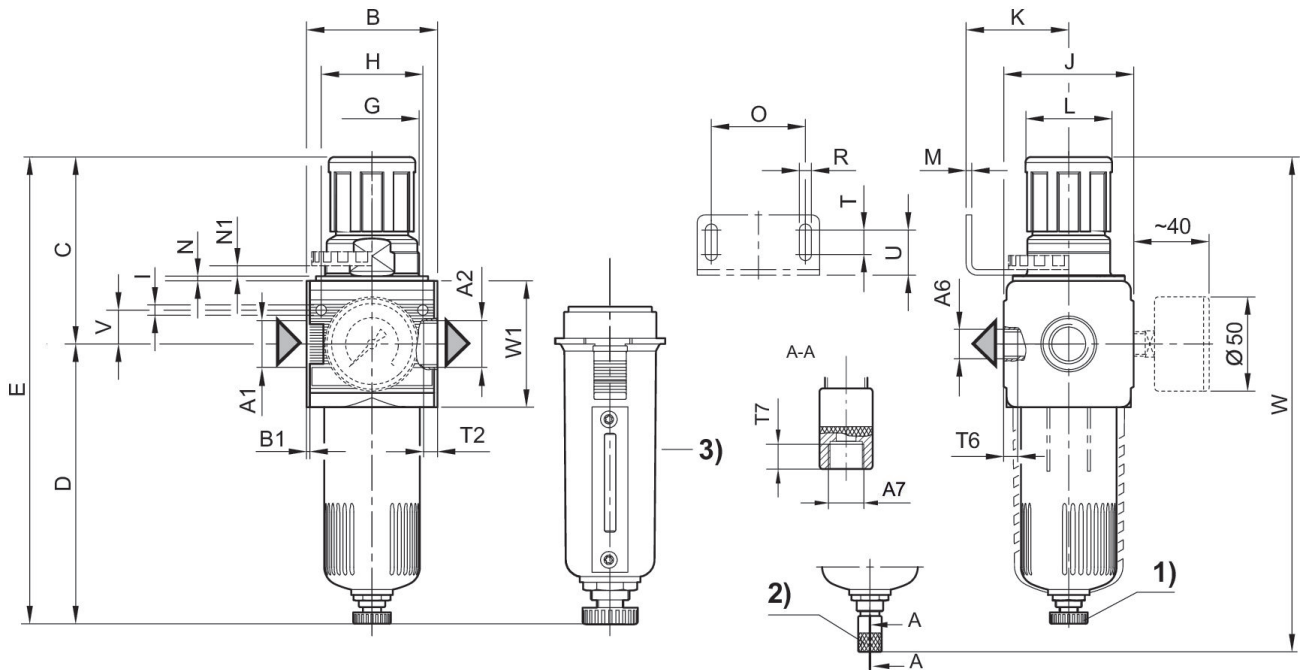

A1 = input A2 = output A6 = output

A7 = condensate drain

1) Semi-automatic condensate drain 2) fully automatic condensate drain

3) Metal reservoir with level indicator

Flow rate characteristic, $p_2 = 0,05 - 7$ bar

Pressure characteristics curve

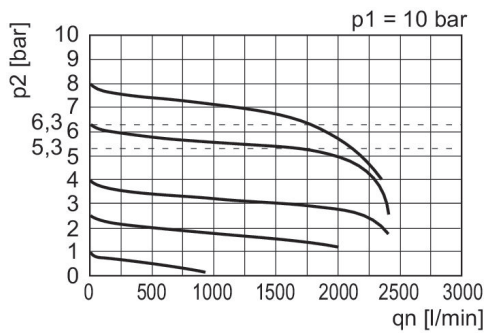

p_1 = Working pressure p_2 = Secondary pressure q_n = Nominal flow

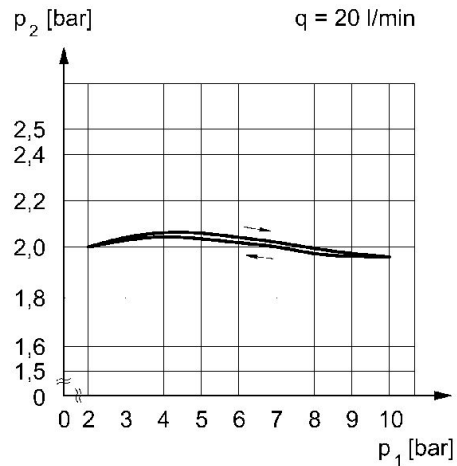

p_1 = working pressure p_2 = secondary pressure q = flow rate

Dimensions in mm

Part No.	A1	A2	A6	A7	B	B1	C	D	E
0821300316	G 1/4	G 1/4	G 1/4	G 1/8	48	1.5	66.5	124.5	191

Filter pressure regulator, Series NL2-FRE

0821300316

NL2

2024-04-23

Part No.	A1	A2	A6	A7	B	B1	C	D	E
0821300275	G 1/4	G 1/4	G 1/4	G 1/8	48	1.5	66.5	124.5	191
0821300347	G 1/4	G 1/4	G 1/4	G 1/8	48	1.5	66.5	124.5	191
0821300343	G 3/8	G 3/8	G 1/4	G 1/8	48	1.5	66.5	124.5	191

Part No.	G	H	I	J	K	L	M	N	N1
0821300316	M30x1,5	36	4.4	47	43.5	28	3	3.5	3
0821300275	M30x1,5	36	4.4	47	43.5	28	3	3.5	3
0821300347	M30x1,5	36	4.4	47	43.5	28	3	3.5	3
0821300343	M30x1,5	36	4.4	47	43.5	28	3	3.5	3

Part No.	O	R	T	T2	T6	T7	U	V	W
0821300316	38	5.4	8	9.5	7	8.5	18.5	12.3	207
0821300275	38	5.4	8	9.5	7	8.5	18.5	12.3	207
0821300347	38	5.4	8	9.5	7	8.5	18.5	12.3	207
0821300343	38	5.4	8	9.5	7	8.5	18.5	12.3	207

Part No.	W1
0821300316	52
0821300275	52
0821300347	52
0821300343	52