

0821301408

## AVENTICS Series NL2 Air Preparation Units

The AVENTICS Series NL maintenance units are suitable for all areas: as individual components or as assembled maintenance units, for centralized or decentralized compressed air preparation, in compact or powerful versions, for use in high or low temperatures. This line offers a complete, customizable compressed air preparation technology. It includes an option to combine every component in the Series to achieve the desired function, making it possible to adjust the components precisely to the application requirements.

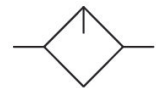

### Technical data

Industry	Industrial
Parts	Lubricator
Reservoir	reservoir, PA, without protective guard
Lubricator version	with level indicator
Compressed air connection	G 1/4
Nominal flow Qn	1800 l/min
Mounting orientation	vertical
Min. working pressure	0.5 bar
Max. working pressure	16 bar
Min. ambient temperature	-10 °C
Max. ambient temperature	60 °C
Medium	Compressed air Neutral gases
Type of filling	Manual oil filling
Lubricator reservoir volume	50 cm <sup>3</sup>
Electrical level indicator	with internal query
Oil dosing at 1000 l/min	1-2 drops
Function	Oil-mist lubricator
Function	Can be assembled into blocks
Weight	0.37 kg

## Material

Housing material	Die cast zinc
Material front plate	Acrylonitrile butadiene styrene
Seal material	Acrylonitrile butadiene rubber
Material reservoir	Polycarbonate
Part No.	0821301408

## Technical information

The pressure dew point must be at least 15 °C less than ambient and medium temperature and may not exceed 3 °C.

The entire preset drip quantity enters the pressure system.

Manual oil filling possible during operation.

Note: Polycarbonate reservoirs are susceptible to solvents, supplementary information can be found at "Customer information".

A change in the flow direction (from air supply on the left to air supply on the right) occurs by rotating installation by 180° about the vertical axis. Please see the operating instructions for further details.

Nominal flow  $Q_n$  with secondary pressure  $p_2 = 6$  bar at  $\Delta p = 0,1$  bar

Fig. 2

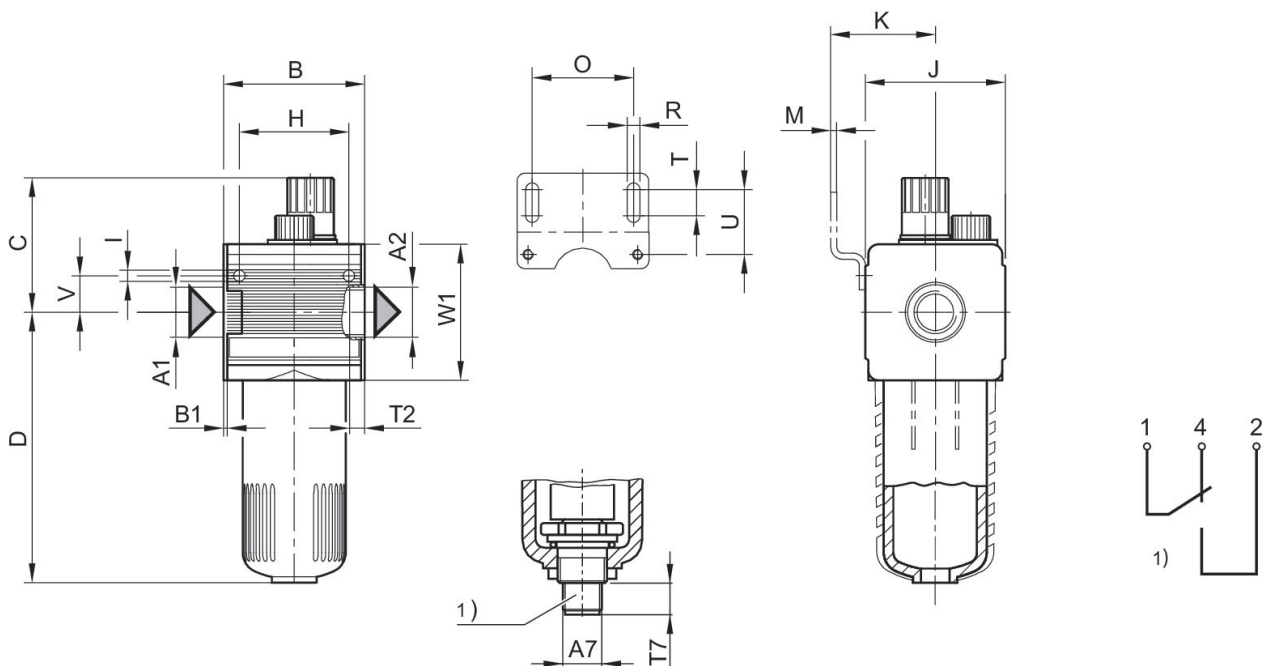

A1 = input A2 = output

1) electrical level indicator – connection: 4-pin, M12x1 – contact load: 50 V AC/0.5 A/5 W – type: 1 change-over contact (make contact/break contact) for min. fluid level

Order valve plug connector (M12x1) separately

0821301408

## Dimensions in mm

Part No.	A1	A2	A7	B	B1	C	D	H	I
0821301408	G 1/4	G 1/4	M12x1	48	1.5	58	109	36	4.4

Part No.	J	K	M	O	R	T	T2	T7	U
0821301408	47	43.5	3	38	5.4	8	9.5	12	27.5

Part No.	V	W1
0821301408	12.3	52

Fig. 1

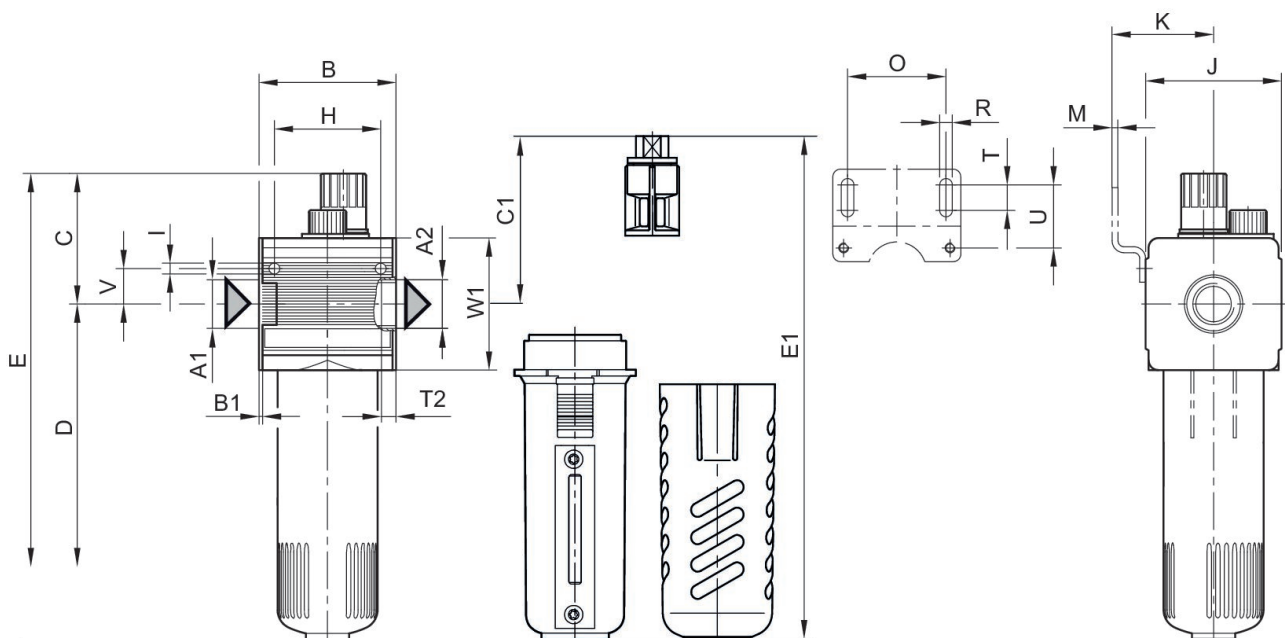

A1 = input A2 = output

## Dimensions in mm

Part No.	A1	A2	B	B1	C	C1	D	E	E1
0821301400	G 1/4	G 1/4	48	1.5	58	-	109	167	-
0821301401	G 1/4	G 1/4	48	1.5	58	-	109	167	-
0821301402	G 1/4	G 1/4	48	1.5	73.5	73,5	109	182	182
0821301440	G 3/8	G 3/8	48	1.5	58	-	109	167	-
0821301441	G 3/8	G 3/8	48	1.5	58	-	109	167	-
0821301442	G 3/8	G 3/8	48	1.5	73.5	73,5	109	182	182

0821301408

Part No.	H	I	J	K	M	O	R	T	T2
0821301400	36	4.4	47	43.5	3	38	5.4	8	9.5
0821301401	36	4.4	47	43.5	3	38	5.4	8	9.5
0821301402	36	4.4	47	43.5	3	38	5.4	8	9.5
0821301440	36	4.4	47	43.5	3	38	5.4	8	6
0821301441	36	4.4	47	43.5	3	38	5.4	8	6
0821301442	36	4.4	47	43.5	3	38	5.4	8	6

Part No.	U	V	W1
0821301400	27.5	12.3	52
0821301401	27.5	12.3	52
0821301402	27.5	12.3	52
0821301440	27.5	12.3	52
0821301441	27.5	12.3	52
0821301442	27.5	12.3	52

Flow rate characteristic,  $p_2 = 0,05 - 7$  bar

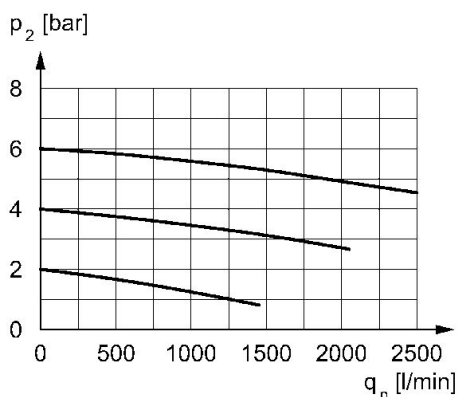

$p_2$  = secondary pressure  $q_n$  = nominal flow

minimum flow rate curve (flow rate necessary for the correct functioning of the lubricator)

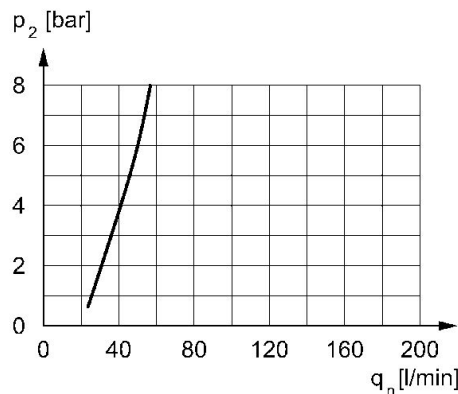

$p_2$  = secondary pressure  $q_{nmin}$  = min. nominal flow