

0821301441

AVENTICS Series NL2 Air Preparation Units

The AVENTICS Series NL maintenance units are suitable for all areas: as individual components or as assembled maintenance units, for centralized or decentralized compressed air preparation, in compact or powerful versions, for use in high or low temperatures. This line offers a complete, customizable compressed air preparation technology. It includes an option to combine every component in the Series to achieve the desired function, making it possible to adjust the components precisely to the application requirements.

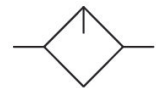

Technical data

Industry	Industrial
Parts	Lubricator
Reservoir	reservoir, polycarbonate, with metal protective guard
Compressed air connection	G 3/8
Nominal flow Qn	1800 l/min
Mounting orientation	vertical
Min. working pressure	0.5 bar
Max. working pressure	16 bar
Min. ambient temperature	-10 °C
Max. ambient temperature	60 °C
Medium	Compressed air Neutral gases
Type of filling	Manual oil filling
Lubricator reservoir volume	50 cm ³
Protective guard	with protective guard
Oil dosing at 1000 l/min	1-2 drops
Function	Oil-mist lubricator
Function	Can be assembled into blocks
Weight	0.368 kg

0821301441

Material

Housing material	Die cast zinc
Material front plate	Acrylonitrile butadiene styrene
Seal material	Acrylonitrile butadiene rubber
Material reservoir	Polycarbonate
Material protective guard	Steel, chrome-plated
Part No.	0821301441

Technical information

The pressure dew point must be at least 15 °C less than ambient and medium temperature and may not exceed 3 °C.

The entire preset drip quantity enters the pressure system.

Manual oil filling possible during operation.

Note: Polycarbonate reservoirs are susceptible to solvents, supplementary information can be found at "Customer information".

A change in the flow direction (from air supply on the left to air supply on the right) occurs by rotating installation by 180° about the vertical axis. Please see the operating instructions for further details.

Nominal flow Q_n with secondary pressure $p_2 = 6$ bar at $\Delta p = 0,1$ bar

Fig. 2

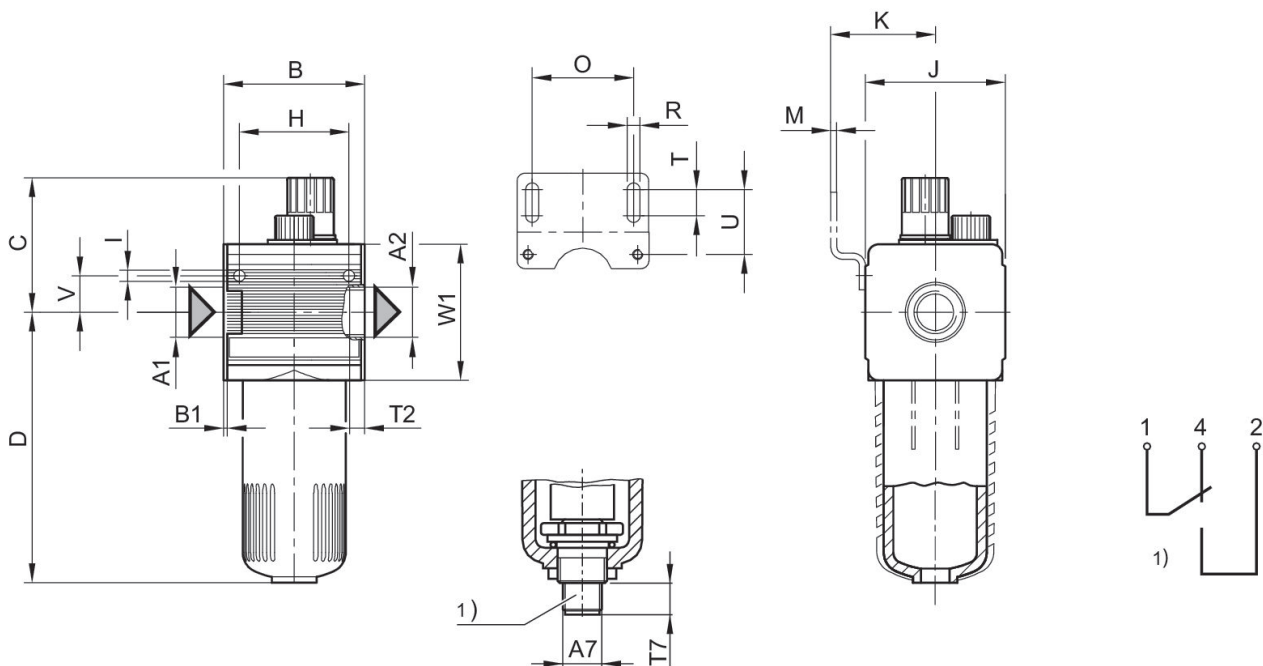

A1 = input A2 = output

Standard oil-mist lubricator, Series NL2-LBS

2024-04-23

0821301441

1) electrical level indicator – connection: 4-pin, M12x1 – contact load: 50 V AC/0.5 A/5 W – type: 1 change-over contact (make contact/break contact) for min. fluid level
Order valve plug connector (M12x1) separately

Dimensions in mm

Part No.	A1	A2	A7	B	B1	C	D	H	I
0821301408	G 1/4	G 1/4	M12x1	48	1.5	58	109	36	4.4

Part No.	J	K	M	O	R	T	T2	T7	U
0821301408	47	43.5	3	38	5.4	8	9.5	12	27.5

Part No.	V	W1
0821301408	12.3	52

Fig. 1

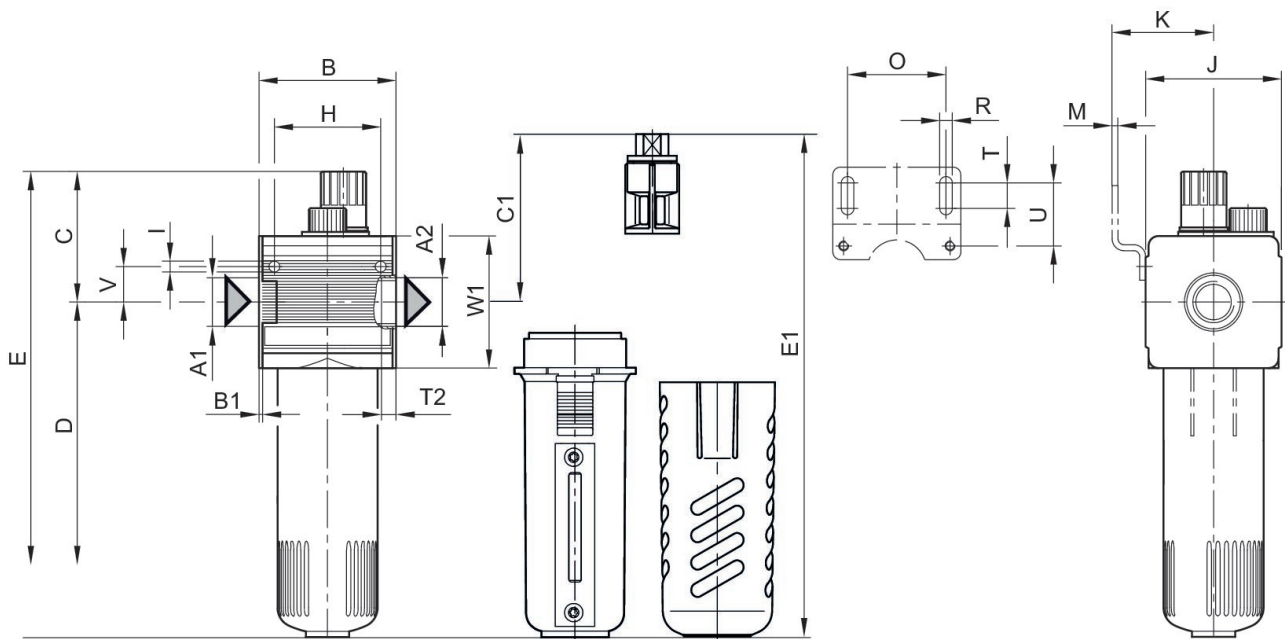

A1 = input A2 = output

Dimensions in mm

Part No.	A1	A2	B	B1	C	C1	D	E	E1
0821301400	G 1/4	G 1/4	48	1.5	58	-	109	167	-
0821301401	G 1/4	G 1/4	48	1.5	58	-	109	167	-
0821301402	G 1/4	G 1/4	48	1.5	73.5	73,5	109	182	182
0821301440	G 3/8	G 3/8	48	1.5	58	-	109	167	-
0821301441	G 3/8	G 3/8	48	1.5	58	-	109	167	-

Standard oil-mist lubricator, Series NL2-LBS

2024-04-23

0821301441

Part No.	A1	A2	B	B1	C	C1	D	E	E1
0821301442	G 3/8	G 3/8	48	1.5	73.5	73,5	109	182	182

Part No.	H	I	J	K	M	O	R	T	T2
0821301400	36	4.4	47	43.5	3	38	5.4	8	9.5
0821301401	36	4.4	47	43.5	3	38	5.4	8	9.5
0821301402	36	4.4	47	43.5	3	38	5.4	8	9.5
0821301440	36	4.4	47	43.5	3	38	5.4	8	6
0821301441	36	4.4	47	43.5	3	38	5.4	8	6
0821301442	36	4.4	47	43.5	3	38	5.4	8	6

Part No.	U	V	W1
0821301400	27.5	12.3	52
0821301401	27.5	12.3	52
0821301402	27.5	12.3	52
0821301440	27.5	12.3	52
0821301441	27.5	12.3	52
0821301442	27.5	12.3	52

Flow rate characteristic, $p_2 = 0,05 - 7$ bar

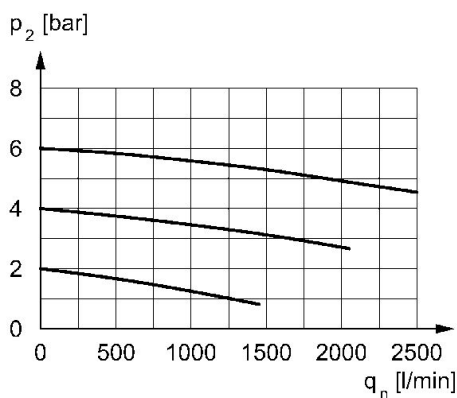

p_2 = secondary pressure q_n = nominal flow

minimum flow rate curve (flow rate necessary for the correct functioning of the lubricator)

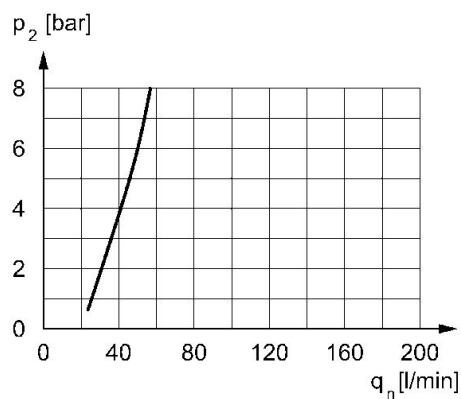

p_2 = secondary pressure $q_{nmin.}$ = min. nominal flow