

AVENTICS Series NL4 Air Preparation Units

The AVENTICS Series NL maintenance units are suitable for all areas: as individual components or as assembled maintenance units, for centralized or decentralized compressed air preparation, in compact or powerful versions, for use in high or low temperatures. This line offers a complete, customizable compressed air preparation technology. It includes an option to combine every component in the Series to achieve the desired function, making it possible to adjust the components precisely to the application requirements.



Technical data

Industry	Industrial
Parts	Active carbon filter
Reservoir	reservoir, metal, long, without inspection glass
Port	G 1/4
Nominal flow Qn	2250 l/min
Condensate drain	without
Min. working pressure	0.5 bar
Max. working pressure	16 bar
Min. ambient temperature	-10 °C
Max. ambient temperature	60 °C
Medium	Compressed air Neutral gases
Max. achievable compressed air class acc. to ISO 8573-1:2010	- : - : 1
Filter reservoir volume	50 cm ³
Filter element	exchangeable
Recommended pre-filtering	0.01 µm
Weight	0.836 kg
Mounting orientation	vertical
Type	Can be assembled into blocks

Active carbon filter, Series NL4-FLA

2024-04-24

0821303301

Material

Housing material	Die cast zinc
Material front plate	Acrylonitrile butadiene styrene
Seal material	Acrylonitrile butadiene rubber
Material reservoir	Die cast zinc
Material filter insert	Active carbon
Part No.	0821303301

Technical information

The pressure dew point must be at least 15 °C less than ambient and medium temperature and may not exceed 3 °C.

Note: Polycarbonate reservoirs are susceptible to solvents, supplementary information can be found at "Customer information".

A change in the flow direction (from air supply on the left to air supply on the right) occurs by rotating installation by 180° about the vertical axis. Please see the operating instructions for further details.

Nominal flow Q_n with secondary pressure $p_2 = 6$ bar at $\Delta p = 0,1$ bar

Dimensions

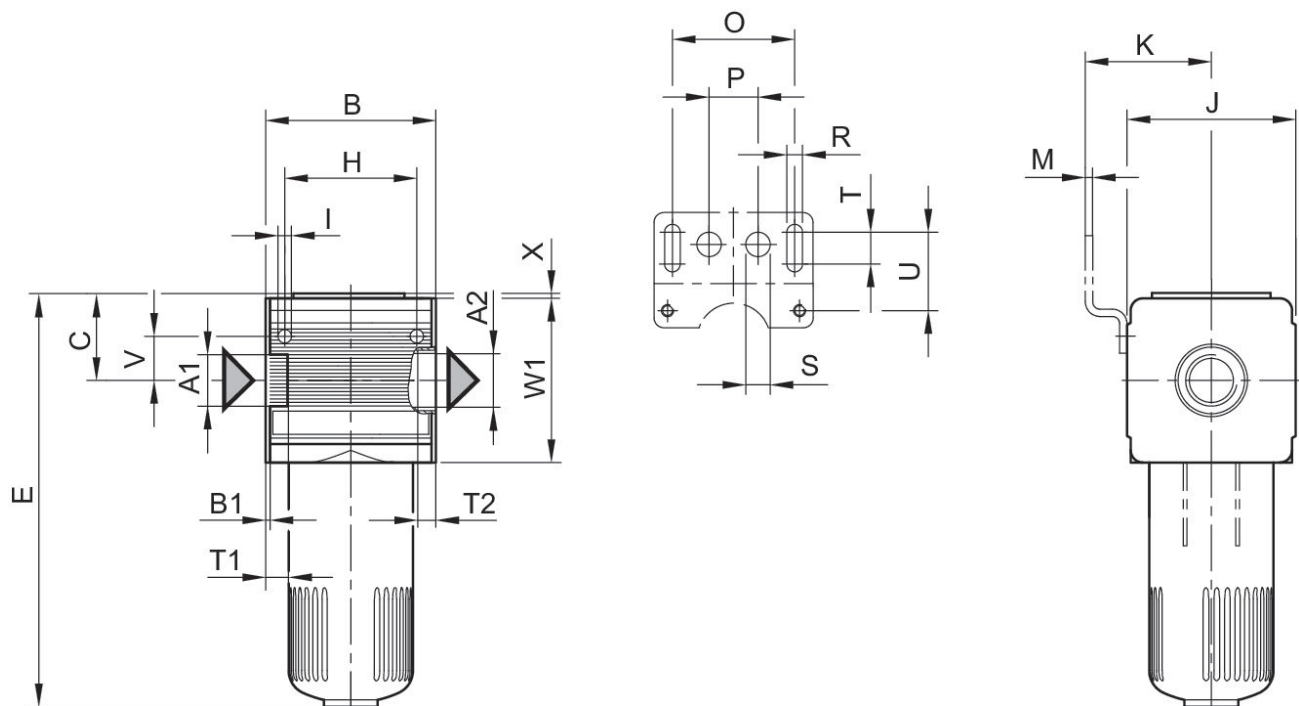

A1 = input A2 = output

Dimensions in mm

Part No.	A1	A2	B	B1	C	D	E	H	I
0821303300	G 1/4	G 1/4	69.6	1.8	34.5	–	170	54	5.5
0821303301	G 1/4	G 1/4	69.6	1.8	34.5	–	222	54	5.5
0821303517	G 1/2	G 1/2	69.6	1.8	34.5	–	308	54	5.5

Part No.	J	K	M	O	P	R	S	T	T1
0821303300	69	54.5	3	50	20	6.4	10	13	13
0821303301	69	54.5	3	50	20	6.4	10	13	13
0821303517	69	54.5	3	50	20	6.4	10	13	13

Part No.	T2	U	V	W1	X
0821303300	13	33	18	67	1
0821303301	13	33	18	67	1
0821303517	13	33	18	67	1

Flow rate characteristic, $p_2 = 0,05 - 7$ bar

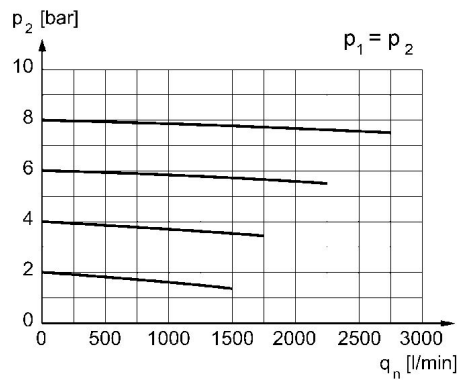

p_2 = secondary pressure q_n = nominal flow