

## AVENTICS Series NL4 Air Preparation Units

The AVENTICS Series NL maintenance units are suitable for all areas: as individual components or as assembled maintenance units, for centralized or decentralized compressed air preparation, in compact or powerful versions, for use in high or low temperatures. This line offers a complete, customizable compressed air preparation technology. It includes an option to combine every component in the Series to achieve the desired function, making it possible to adjust the components precisely to the application requirements.



### Technical data

Industry	Industrial
Parts	Microfilter
Reservoir	reservoir, polycarbonate, with metal protective guard
Port	G 1/2
Filter porosity	0.01 µm
Nominal flow Qn	720 l/min
Condensate drain	semi-automatic, open without pressure
Min. working pressure	1.5 bar
Max. working pressure	16 bar
Min. ambient temperature	-10 °C
Max. ambient temperature	60 °C
Medium	Compressed air Neutral gases
Max. achievable compressed air class acc. to ISO 8573-1:2010	1 : - : 2
Filter reservoir volume	25 cm <sup>3</sup>
Filter element	exchangeable
Recommended pre-filtering	0.3 µm
Weight	1.23 kg

Mounting orientation	vertical
Type	Can be assembled into blocks

## Material

Housing material	Die cast zinc
Material front plate	Acrylonitrile butadiene styrene
Seal material	Acrylonitrile butadiene rubber
Material threaded bushing	Die cast zinc
Material reservoir	Polycarbonate
Material protective guard	Steel, chrome-plated
Material filter insert	Borosilicate glass fiber
Part No.	R412010794

## Technical information

The pressure dew point must be at least 15 °C less than ambient and medium temperature and may not exceed 3 °C.

Note: Polycarbonate reservoirs are susceptible to solvents, supplementary information can be found at "Customer information".

A change in the flow direction (from air supply on the left to air supply on the right) occurs by rotating installation by 180° about the vertical axis. Please see the operating instructions for further details.

Nominal flow  $Q_n$  with secondary pressure  $p_2 = 6$  bar at  $\Delta p = 0,1$  bar

## Dimensions

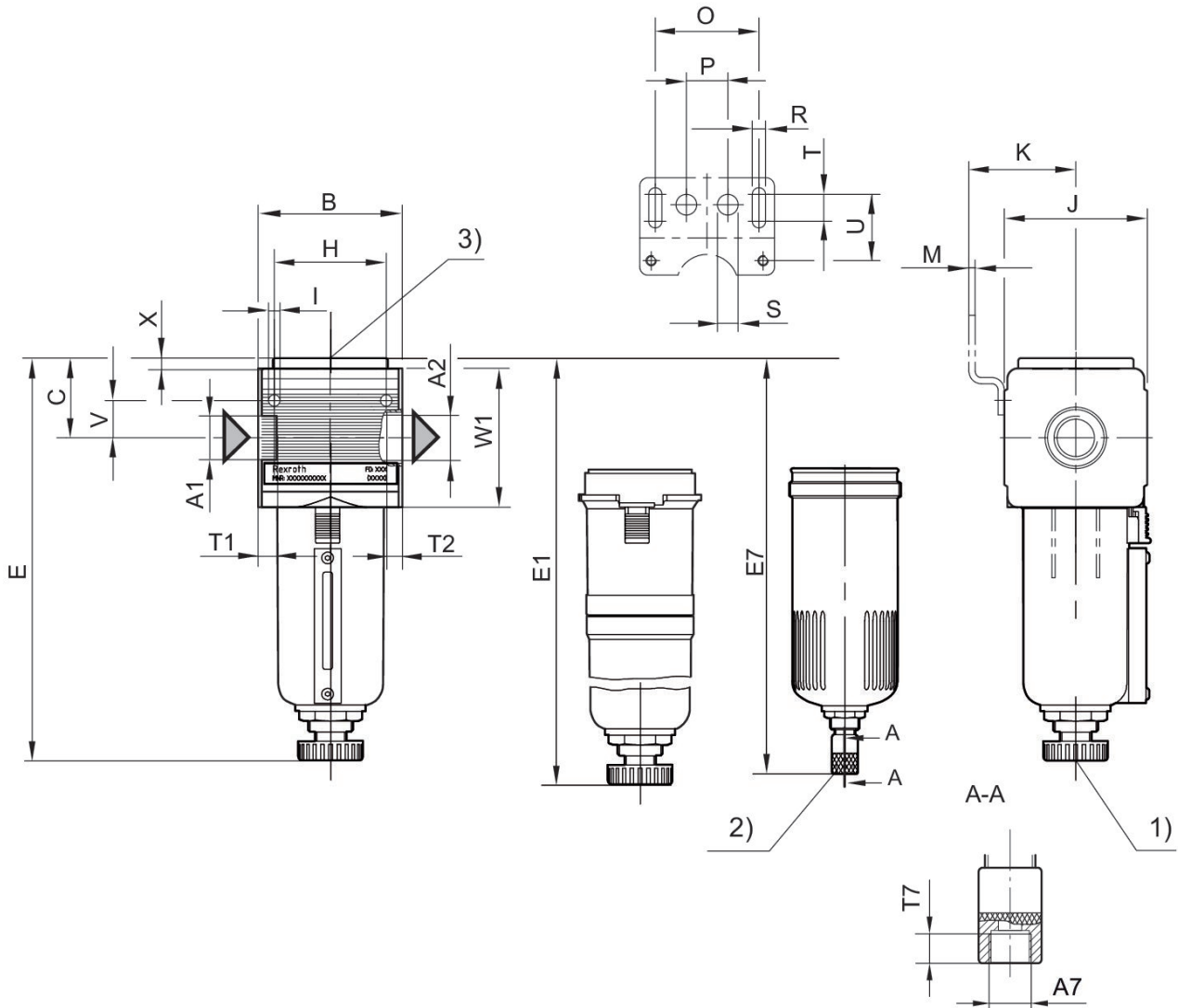

A1 = input A2 = output  
A7 = condensate drain

1) semi-automatic condensate drain 2) fully automatic condensate drain 3) differential pressure gauge connection

## Dimensions in mm

Part No.	A1	A2	A7	B	C	E	E1	E7	H
0821303418	G 1/4	G 1/4	G 1/8	69.6	38.5	202	-	-	54
0821303419	G 1/4	G 1/4	G 1/8	69.6	-	-	249	-	54
0821303514	G 1/2	G 1/2	G 1/8	69.6	39.5	186	-	-	54
0821303516	G 1/2	G 1/2	G 1/8	69.6	38.5	-	335	-	54
R412010794	G 1/2	G 1/2	G 1/8	69.6	38.5	-	186	-	54
R412010795	G 1/2	G 1/2	G 1/8	69.6	38.5	186	-	-	54
0821303571	G 1/2	G 1/2	G 1/8	69.6	38.5	-	-	201	54
R412010796	G 1/2	G 1/2	G 1/8	69.6	38.5	-	-	201	54

# Microfilter, Series NL4-FLC

2024-04-24

R412010794

Part No.	A1	A2	A7	B	C	E	E1	E7	H
R412010797	G 1/2	G 1/2	G 1/8	69.6	38.5	–	–	201	54

Part No.	I	J	K	M	O	P	R	S	T
0821303418	5.5	69	54.5	3	50	20	6.4	10	13
0821303419	5.5	69	54.5	3	50	20	6.4	10	13
0821303514	5.5	69	54.5	3	50	20	6.4	10	13
0821303516	5.5	69	54.5	3	50	20	6.4	10	13
R412010794	5.5	69	54.5	3	50	20	6.4	10	13
R412010795	5.5	69	54.5	3	50	20	6.4	10	13
0821303571	5.5	69	54.5	3	50	20	6.4	10	13
R412010796	5.5	69	54.5	3	50	20	6.4	10	13
R412010797	5.5	69	54.5	3	50	20	6.4	10	13

Part No.	T1	T2	T7	U	V	W1	X
0821303418	13	13	8.5	33	18	67	5
0821303419	13	13	8.5	33	18	67	–
0821303514	13	13	8.5	33	18	67	–
0821303516	13	13	8.5	33	18	67	5
R412010794	13	13	8.5	33	18	67	–
R412010795	13	13	8.5	33	18	67	–
0821303571	13	13	8.5	33	18	67	–
R412010796	13	13	8.5	33	18	67	–
R412010797	13	13	8.5	33	18	67	–

## Flow rate characteristic, $p_2 = 0,05 - 7$ bar

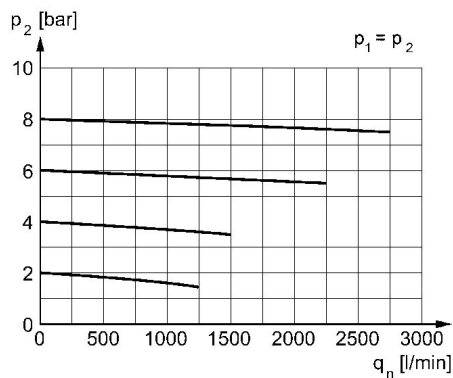

$p_2$  = secondary pressure  $q_n$  = nominal flow