

0821301545

AVENTICS Series NL4 Air Preparation Units

The AVENTICS Series NL maintenance units are suitable for all areas: as individual components or as assembled maintenance units, for centralized or decentralized compressed air preparation, in compact or powerful versions, for use in high or low temperatures. This line offers a complete, customizable compressed air preparation technology. It includes an option to combine every component in the Series to achieve the desired function, making it possible to adjust the components precisely to the application requirements.

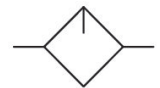

Technical data

Industry	Industrial
Parts	Lubricator
Reservoir	reservoir, polycarbonate, without protective guard
Lubricator version	with level indicator
Compressed air connection	G 3/4
Nominal flow Qn	6000 l/min
Mounting orientation	vertical
Min. working pressure	0.5 bar
Max. working pressure	16 bar
Min. ambient temperature	-10 °C
Max. ambient temperature	60 °C
Medium	Compressed air Neutral gases
Type of filling	Manual oil filling
Lubricator reservoir volume	116 cm ³
Electrical level indicator	with internal query
Oil dosing at 1000 l/min	1-2 drops
Function	Oil-mist lubricator
Function	Can be assembled into blocks
Weight	0.725 kg

0821301545

Material

Housing material	Die cast zinc
Material front plate	Acrylonitrile butadiene styrene
Seal material	Acrylonitrile butadiene rubber
Material threaded bushing	Die cast zinc
Material reservoir	Polycarbonate
Part No.	0821301545

Technical information

The pressure dew point must be at least 15 °C less than ambient and medium temperature and may not exceed 3 °C.

The entire preset drip quantity enters the pressure system.

Manual oil filling possible during operation.

Note: Polycarbonate reservoirs are susceptible to solvents, supplementary information can be found at "Customer information".

A change in the flow direction (from air supply on the left to air supply on the right) occurs by rotating installation by 180° about the vertical axis. Please see the operating instructions for further details.

Nominal flow Q_n with secondary pressure $p_2 = 6 \text{ bar}$ at $\Delta p = 1 \text{ bar}$

Dimensions

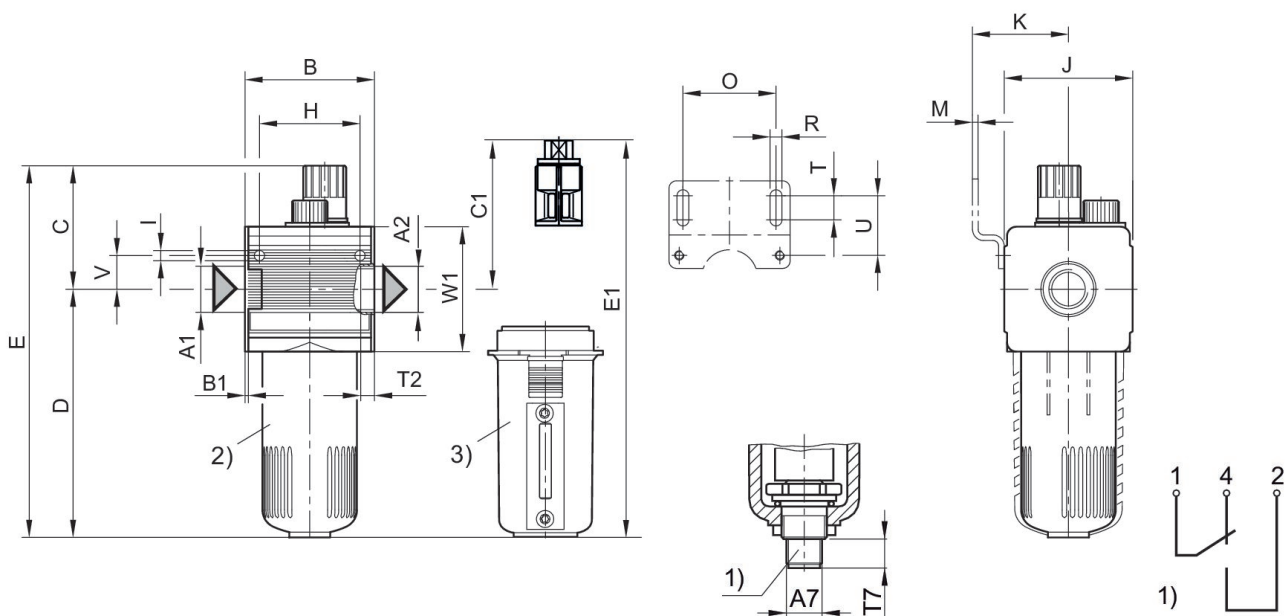

A1 = input A2 = output

1) electrical level indicator – connection: 4-pin, M12x1 – contact load: 50 V AC/0.5 A/5 W – type: 1 change-over contact (make contact/break contact) for min. fluid level

Order valve plug connector (M12x1) separately

Standard oil-mist lubricator, Series NL4-LBS

2024-04-24

0821301545

- 2) PC reservoir
- 3) Metal reservoir with level indicator

Dimensions in mm

Part No. G 1/2	A1	A2	A7	B	B1	C	C1	D	D2
0821301500	G 1/2	G 1/2	M12x1	69.5	1.8	65	-	132	12
0821301501	G 1/2	G 1/2	M12x1	69.5	1.8	65	-	132	12
0821301502	G 1/2	G 1/2	M12x1	69.5	1.8	65	81	132	12
0821301515	G 1/2	G 1/2	M12x1	69.5	1.8	65	-	132	12
0821301540	G 3/4	G 3/4	M12x1	69.5	1.8	65	-	132	12
0821301541	G 3/4	G 3/4	M12x1	69.5	1.8	65	-	132	12
0821301542	G 3/4	G 3/4	M12x1	69.5	1.8	65	81	132	12
0821301545	G 3/4	G 3/4	M12x1	69.5	1.8	65	-	132	12

Part No. G 1/2	E	E1	F	H	I	J	K	M	O
0821301500	197	-	M12x1	54	5.5	67	54.5	3	50
0821301501	197	-	M12x1	54	5.5	67	54.5	3	50
0821301502	197	212	M12x1	54	5.5	67	54.5	3	50
0821301515	197	-	M12x1	54	5.5	67	54.5	3	50
0821301540	197	-	M12x1	54	5.5	67	54.5	3	50
0821301541	197	-	M12x1	54	5.5	67	54.5	3	50
0821301542	197	212	M12x1	54	5.5	67	54.5	3	50
0821301545	197	-	M12x1	54	5.5	67	54.5	3	50

Part No. G 1/2	P	R	S	T	T2	T7	U	V	W1
0821301500	20	6.4	10	13	13	12	33	18	67
0821301501	20	6.4	10	13	13	12	33	18	67
0821301502	20	6.4	10	13	13	12	33	18	67
0821301515	20	6.4	10	13	13	12	33	18	67
0821301540	20	6.4	10	13	13	12	33	18	67
0821301541	20	6.4	10	13	13	12	33	18	67
0821301542	20	6.4	10	13	13	12	33	18	67
0821301545	20	6.4	10	13	13	12	33	18	67

Flow rate characteristic, $p_2 = 0,05 - 7$ bar

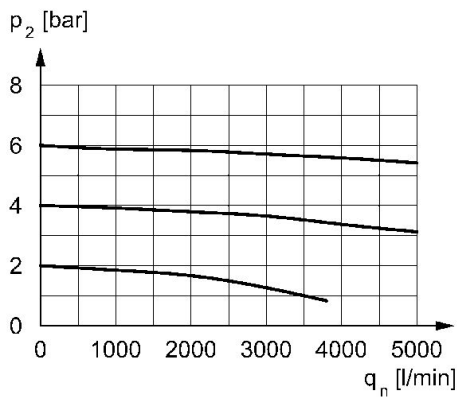

p_2 = secondary pressure q_n = nominal flow

minimum flow rate curve (flow rate necessary for the correct functioning of the lubricator)

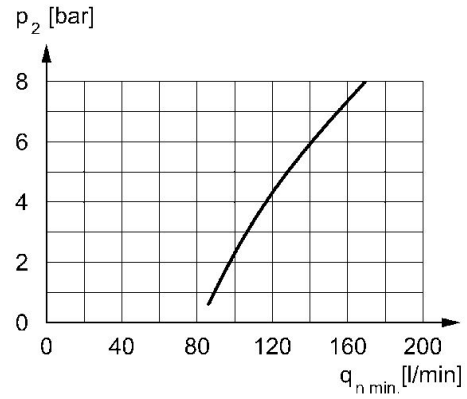

p_2 = secondary pressure $q_{n \min.}$ = min. nominal flow