

0821302513

AVENTICS Series NL4 Air Preparation Units

The AVENTICS Series NL maintenance units are suitable for all areas: as individual components or as assembled maintenance units, for centralized or decentralized compressed air preparation, in compact or powerful versions, for use in high or low temperatures. This line offers a complete, customizable compressed air preparation technology. It includes an option to combine every component in the Series to achieve the desired function, making it possible to adjust the components precisely to the application requirements.



Technical data

Industry	Industrial
Function	Precision pressure regulator
Parts	Precision pressure regulator
Pressure gauge	without pressure gauge
Mounting orientation	Any
Regulator type	Diaphragm-type pressure regulator
Port	G 1/2
Nominal flow Qn	6000 l/min
Min. regulation range	0.5 bar
Max. regulation range	10 bar
Min. working pressure	0.5 bar
Max. working pressure	16 bar
Min. ambient temperature	-10 °C
Max. ambient temperature	60 °C
Activation	Mechanical
Regulator function	with relieving air exhaust
Regulator type	Can be assembled into blocks
Pressure supply	single
Lock type	not lockable

Precision pressure regulator, Series NL4-RGP

2024-04-24

0821302513

Max. internal air consumption q_v	2.6 l/min
Medium	Compressed air Neutral gases
Recommended pre-filtering	5 μm
Weight	0.867 kg

Material

Housing material	Die cast zinc
Material front plate	Acrylonitrile butadiene styrene
Seal material	Acrylonitrile butadiene rubber
Part No.	0821302513

Technical information

The pressure dew point must be at least 15 °C less than ambient and medium temperature and may not exceed 3 °C.

Nominal flow Q_n with secondary pressure $p_2 = 6$ bar at $\Delta p = 1$ bar

A change in the flow direction (from air supply on the left to air supply on the right) occurs by rotating installation by 180° about the vertical axis. Please see the operating instructions for further details.

Order pressure gauge separately

Dimensions

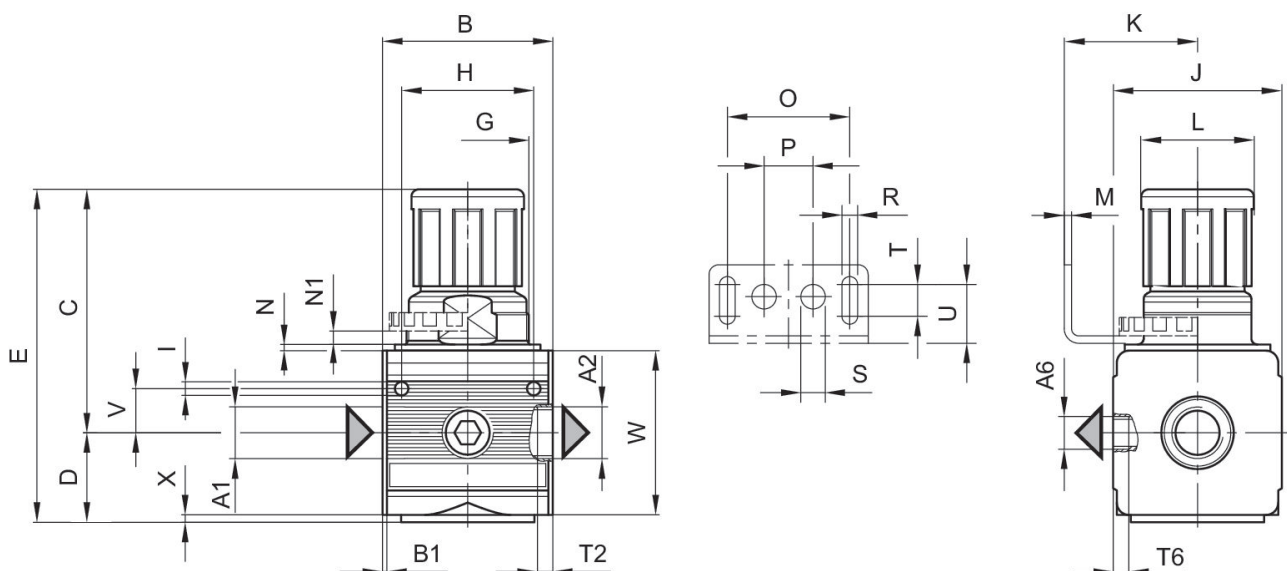

A1 = input A2 = output
A6 = output

Dimensions in mm

Part No.	A1	A2	A6	B	B1	C	D	E	G
0821302511	G 1/2	G 1/2	G 1/4	69.6	1.8	97	35.5	132.5	M50x1,5
0821302512	G 1/2	G 1/2	G 1/4	69.6	1.8	97	35.5	132.5	M50x1,5
0821302513	G 1/2	G 1/2	G 1/4	69.6	1.8	97	35.5	132.5	M50x1,5

Part No.	H	I	J	K	L	M	N	N1	O
0821302511	54	5.5	69	54.5	46	3	3	5.5	50
0821302512	54	5.5	69	54.5	46	3	3	5.5	50
0821302513	54	5.5	69	54.5	46	3	3	5.5	50

Part No.	P	R	S	T	T2	T6	U	V	W
0821302511	20	6.4	10	13	13	7	24	18	67
0821302512	20	6.4	10	13	13	7	24	18	67
0821302513	20	6.4	10	13	13	7	24	18	67

Part No.	X
0821302511	2
0821302512	2
0821302513	2

Flow rate characteristic, $p_2 = 0,05 - 7$ bar

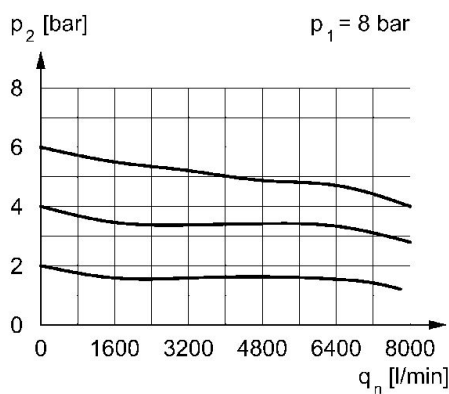

p_1 = Working pressure p_2 = Secondary pressure q_n = Nominal flow
 $p_2 = 0,5 - 10$ bar

Flow rate characteristic, $p_2 = 0,05 - 7$ bar

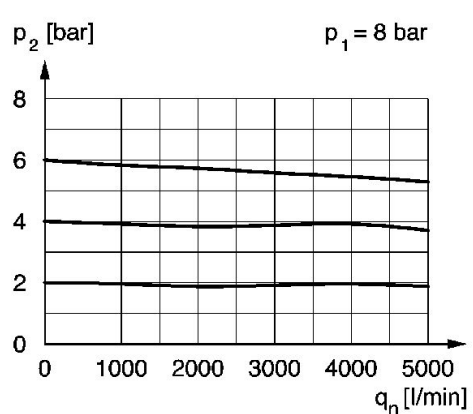

p_1 = Working pressure p_2 = Secondary pressure q_n = Nominal flow
 $p_2 = 0,2 - 6$ bar

Flow rate characteristic, $p_2 = 0,05 - 7$ bar Pressure characteristics curve

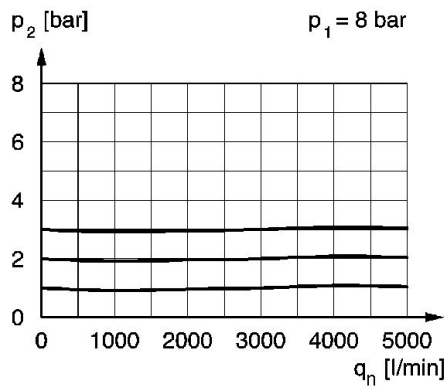

p_1 = Working pressure p_2 = Secondary pressure q_n = Nominal flow
 $p_2 = 0,1 - 3$ bar

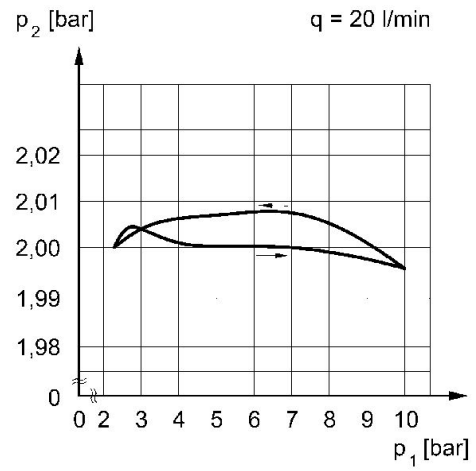

p_1 = working pressure p_2 = secondary pressure q = flow rate