

# Filling unit, electrically operated, Series NL6-SSU

0821300959

General series information  
Series NL6

- The AVENTICS Series NL maintenance units are suitable for all areas: as individual components or as assembled maintenance units, for centralized or decentralized compressed air preparation, in compact or powerful versions, for use in high or low temperatures. This line offers a complete, customizable compressed air preparation technology. It includes an option to combine every component in the Series to achieve the desired function, making it possible to adjust the components precisely to the application requirements.

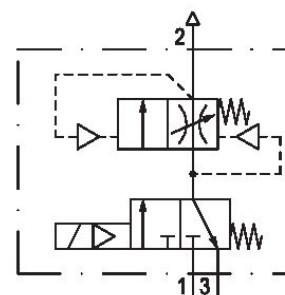

## Technical data

Industry	Industrial
Activation	Electrically
Nominal flow Qn	8750 l/min
Compressed air connection	G 3/4
Working pressure min.	2.5 bar
Working pressure max	10 bar
DC operating voltage	24 V
Sealing principle	Soft Seal
Pilot	Internal
Connection type	Pipe connection
Parts	3/2-directional valve Filling valve
Can be assembled into blocks	Can be assembled into blocks
Type	Poppet valve

Min. ambient temperature	-10 °C
Max. ambient temperature	60 °C
Medium	Compressed air Neutral gases
Recommended pre-filtering	8 µm
Compressed air connection, exhaust	G 1/2
Nominal flow Qn 1 to 2	8750 l/min
Nominal flow Qn 2 to 3	3900 l/min
Power consumption DC	4.8 W
Duty cycle	100 %
Protection class with connection	IP65
Reverse polarity protection	Protected against polarity reversal
Electrical connection type 2	Plug
Electrical connection 2, thread size	ISO 6952, form B
Weight	3.13 kg

## Material

Housing material	Die-cast aluminum
Seal material	Acrylonitrile butadiene styrene
Material front plate	Acrylonitrile butadiene styrene
Part No.	0821300959

## Technical information

The pressure dew point must be at least 15 °C under ambient and medium temperature and may not exceed 3 °C .

Nominal flow Qn with secondary pressure  $p_2 = 6$  bar at  $\Delta p = 1$  bar

A change in the flow direction (from air supply on the left to air supply on the right) occurs by rotating installation by 180° about the vertical axis. Please see the operating instructions for further details.

The filling valve builds up pressure slowly in the pneumatic systems, i.e. prevents a sudden pressure build-up during a recommissioning after a mains pressure failure or avoids emergency OFF switching. This allows dangerous abrupt cylinder motions to be avoided.

Do not position filling valves or filling units upstream of open consumers, such as nozzles, air barriers, air curtains, since these may prevent through connection of components.

## Dimensions

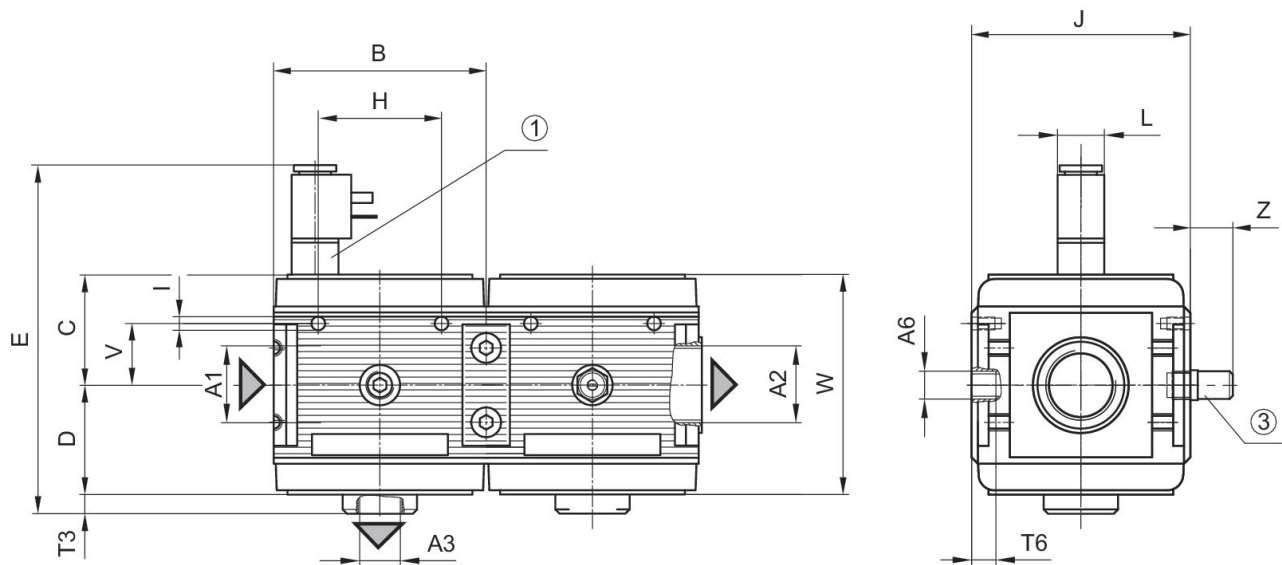

A1 = input A2 = output  
 A3 = ventilation port  
 1) electrically operated  
 2) Adjustment screw for filling time

## Dimensions in mm

Part No.	A1	A2	A3	A6	B	C	D	E	H
0821300959	G 3/4	G 3/4	G 1/2	G 1/4	100	52	51.5	164.5	58
0821300960	G 3/4	G 3/4	G 1/2	G 1/4	100	52	51.5	164.5	58
0821300961	G 1	G 1	G 1/2	G 1/4	100	52	51.5	164.5	58
0821300962	G 1	G 1	G 1/2	G 1/4	100	52	51.5	164.5	58
0821300963	G 1	G 1	G 1/2	G 1/4	100	52	51.5	164.5	58

Part No.	I	J	L	T3	T6	V	W	Z
0821300959	M6	103	22	9.5	7	29	103.5	20
0821300960	M6	103	22	9.5	7	29	103.5	20
0821300961	M6	103	22	9.5	7	29	103.5	20
0821300962	M6	103	22	9.5	7	29	103.5	20
0821300963	M6	103	22	9.5	7	29	103.5	20

### Secondary pressure while filling

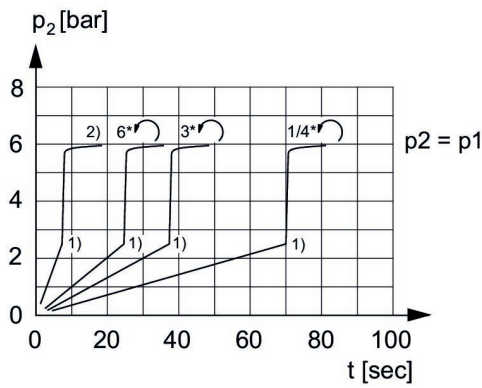

p1 = Working pressure  
 p2 = Secondary pressure  
 t = filling time, adjustable via adjustment screw (throttle)  
 1) Switching point: adjustable filling time, fixed change-over pressure  $\approx 0.5 \times p1$  (50%)  
 2) Throttle fully opened  
 \* Adjustment screw rotations

### Flow rate characteristic, p2 = 0,05 - 7 bar

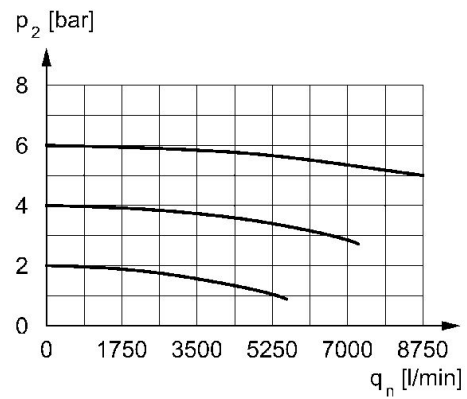

p2 = Secondary pressure  
 qn = Nominal flow