

Filling unit, pneumatically operated, Series NL6-SSU

0821300992

General series information Series NL6

- The AVENTICS Series NL maintenance units are suitable for all areas: as individual components or as assembled maintenance units, for centralized or decentralized compressed air preparation, in compact or powerful versions, for use in high or low temperatures. This line offers a complete, customizable compressed air preparation technology. It includes an option to combine every component in the Series to achieve the desired function, making it possible to adjust the components precisely to the application requirements.

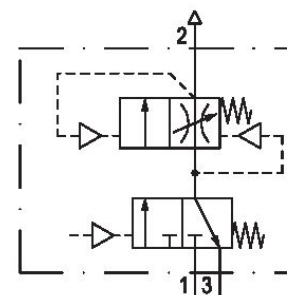

Technical data

Industry
Activation
Parts

Nominal flow Q_n
Compressed air connection
Working pressure min.
Working pressure max
Connection type
Sealing principle

Industrial
Pneumatically
3/2-directional valve
Filling valve
8750 l/min
G 3/4
0 bar
16 bar
Pipe connection
Soft Seal

Type	Poppet valve
Pilot	Internal
Can be assembled into blocks	Can be assembled into blocks
Control pressure min.	2.5 bar
Control pressure max.	16 bar
Min. ambient temperature	-10 °C
Max. ambient temperature	60 °C
Medium	Compressed air Neutral gases
Max. particle size	8 µm
Compressed air connection, exhaust	G 1/2
Nominal flow Qn 1 to 2	8750 l/min
Nominal flow Qn 2 to 3	3900 l/min
Weight	3.08 kg

Material

Housing material	Die-cast aluminum
Seal material	Acrylonitrile butadiene rubber
Material, front cover	Acrylonitrile butadiene styrene
Part No.	0821300992

Technical information

The pressure dew point must be at least 15 °C under ambient and medium temperature and may not exceed 3 °C .

Nominal flow Qn with secondary pressure $p_2 = 6$ bar at $\Delta p = 1$ bar

A change in the flow direction (from air supply on the left to air supply on the right) occurs by rotating installation by 180° about the vertical axis. Please see the operating instructions for further details.

The filling valve builds up pressure slowly in the pneumatic systems, i.e. prevents a sudden pressure build-up during a recommissioning after a mains pressure failure or avoids emergency OFF switching. This allows dangerous abrupt cylinder motions to be avoided.

Do not position filling valves or filling units upstream of open consumers, such as nozzles, air barriers, air curtains, since these may prevent through connection of components.

Dimensions

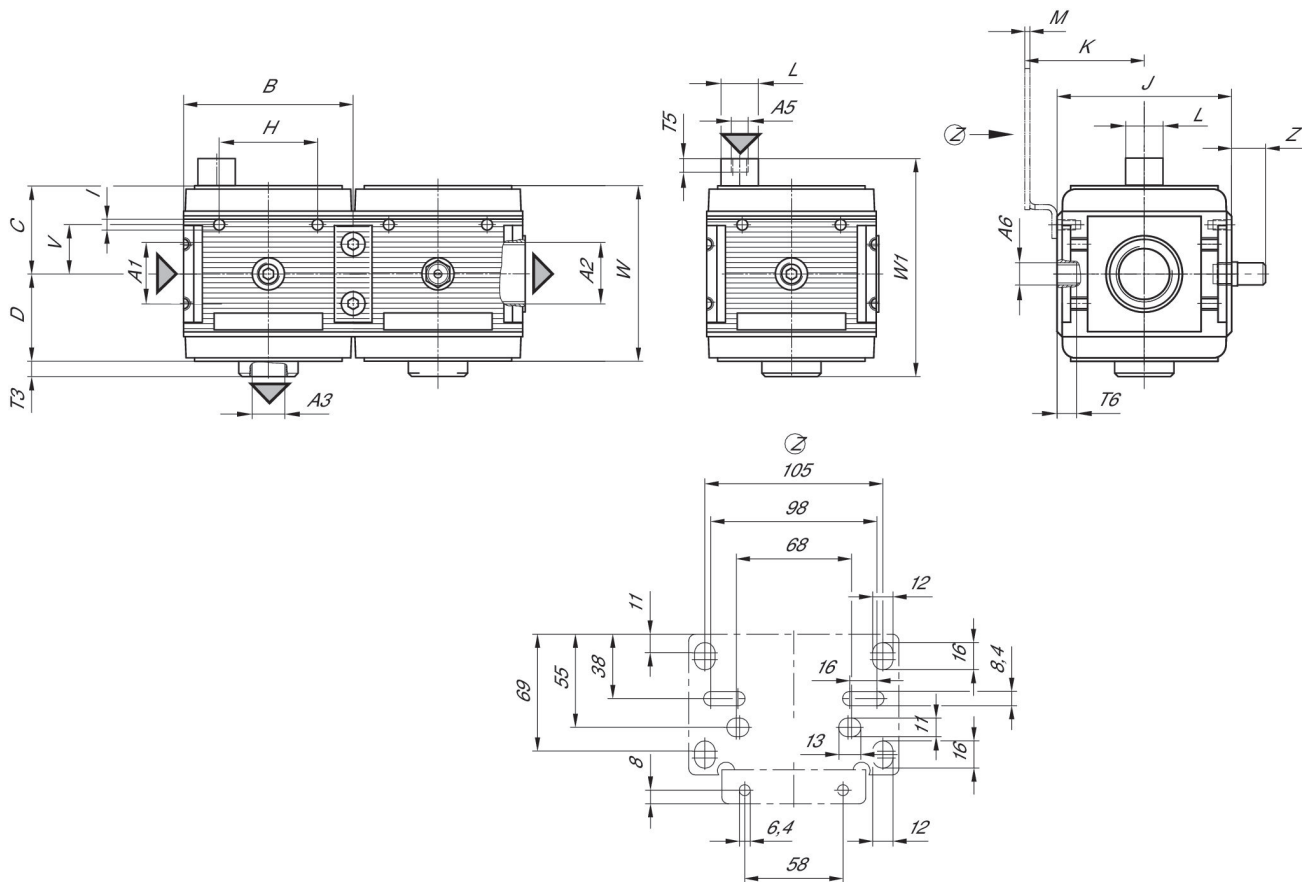

A1 = input A2 = output
 A3 = ventilation port
 A5 = Control pressure connection

Dimensions in mm

Part No.	A1	A2	A3	A5	A6	B	C	D	F
0821300992	G 3/4	G 3/4	G 1/2	G 1/8	G 1/4	100	52	51	9.5
0821300993	G 1	G 1	G 1/2	G 1/8	G 1/4	100	52	51	9.5

Part No.	H	I	J	K	L	M	T5	T6	V
0821300992	58	M6	103	70.5	22	3	18	7	29
0821300993	58	M6	103	70.5	22	3	18	7	29

Part No.	W	W1	Z
0821300992	103.5	128.5	20
0821300993	103.5	128.5	20

Secondary pressure while filling

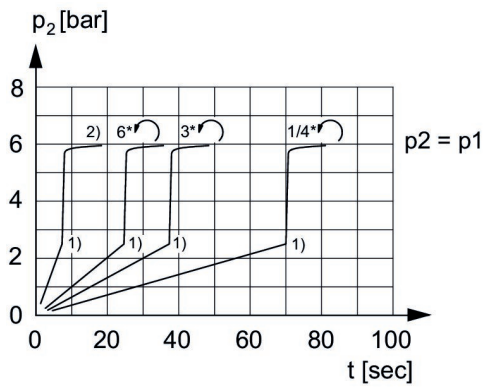

- p1 = Working pressure
- p2 = Secondary pressure
- t = filling time, adjustable via adjustment screw (throttle)
- 1) Switching point: adjustable filling time, fixed change-over pressure $\approx 0.5 \times p1$ (50%)
- 2) Throttle fully opened
- * Adjustment screw rotations

Flow rate characteristic, $p2 = 0,05 - 7$ bar

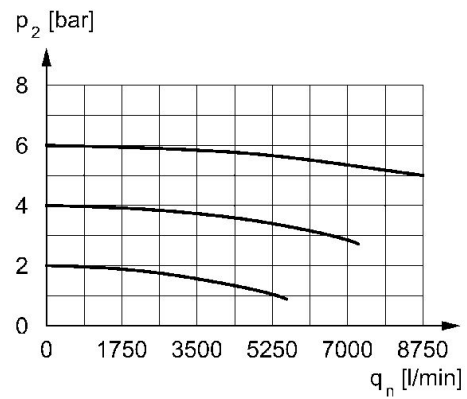

- p2 = Secondary pressure
- qn = Nominal flow