

# Profile cylinder ISO 15552, Series PRA - inch

R480176204

AVENTICS  
Series  
PRA Profile  
cylinders  
(ISO 15552)

## AVENTICS Series PRA Profile cylinders (ISO 15552)

The AVENTICS Series PRA (ISO 15552) cylinders have a compact design profile with integrated sensor slots. The Series PRA (ISO 15552) cylinders can be used for all industries. This includes general automation technology, machine and systems construction, as well as specific industry applications.

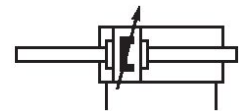

## Technical data

|  |                                    |
|--|------------------------------------|
| Industry                               | Industrial                         |
| Piston Ø                               | 32 mm                              |
| Stroke                                 | 177.8 mm                           |
| Ports                                  | 1/8 NPT                            |
| Functional principle                   | Double-acting                      |
| Cushioning                             | Pneumatic adjustable cushioning    |
| Magnetic piston                        | Piston with magnet                 |
| Environmental requirements             | Industry standard<br>ATEX optional |
| Piston rod thread - type               | External thread                    |
| Piston rod thread                      | 7/16-20 UNF                        |
| Piston rod                             | through                            |
| Scraper                                | Standard Industry Scraper          |
| Pressure for determining piston forces | 6,3 bar                            |
| Retracting piston force                | 435 N                              |
| Extracting piston force                | 435 N                              |
| Min. ambient temperature               | -20 °C                             |
| Max. ambient temperature               | 80 °C                              |
| Min. working pressure                  | 2 bar                              |
| Max. working pressure                  | 10 bar                             |

# Profile cylinder ISO 15552, Series PRA - inch

R480176204

AVENTICS  
Series  
PRA Profile  
cylinders  
(ISO 15552)

2024-04-12

|                                    |                     |
|------------------------------------|---------------------|
| Cushioning length                  | 16.5 mm             |
| Cushioning energy                  | 4.8 J               |
| Weight 0 mm stroke                 | 0.58 kg             |
| Weight +10 mm stroke               | 0.031 kg            |
| Stroke max.                        | 1600 mm             |
| Medium                             | Compressed air      |
| Min. medium temperature            | -20 °C              |
| Max. medium temperature            | 80 °C               |
| Max. particle size                 | 50 µm               |
| Min. oil content of compressed air | 0 mg/m <sup>3</sup> |
| Max. oil content of compressed air | 5 mg/m <sup>3</sup> |

## Material

|                       |                      |
|-----------------------|----------------------|
| Piston rod            | Stainless Steel      |
| Scraper material      | Polyurethane         |
| Seal material         | Polyurethane         |
| Material, front cover | Die-cast aluminum    |
| Cylinder tube         | Aluminum             |
| End cover             | Die-cast aluminum    |
| Nut for piston rod    | Steel, chrome-plated |
| Part No.              | R480176204           |

## Technical information

The pressure dew point must be at least 15 °C less than ambient and medium temperature and may not exceed 3 °C.

The oil content of compressed air must remain constant during the life cycle.

Use only the approved oils from AVENTICS. Further information can be found in the "Technical information" document (available in <https://www.emerson.com/en-us/support>).

# Profile cylinder ISO 1552, Series PRA - inch

R480176204

AVENTICS  
Series  
PRA Profile  
cylinders  
(ISO 1552)

## Dimensions

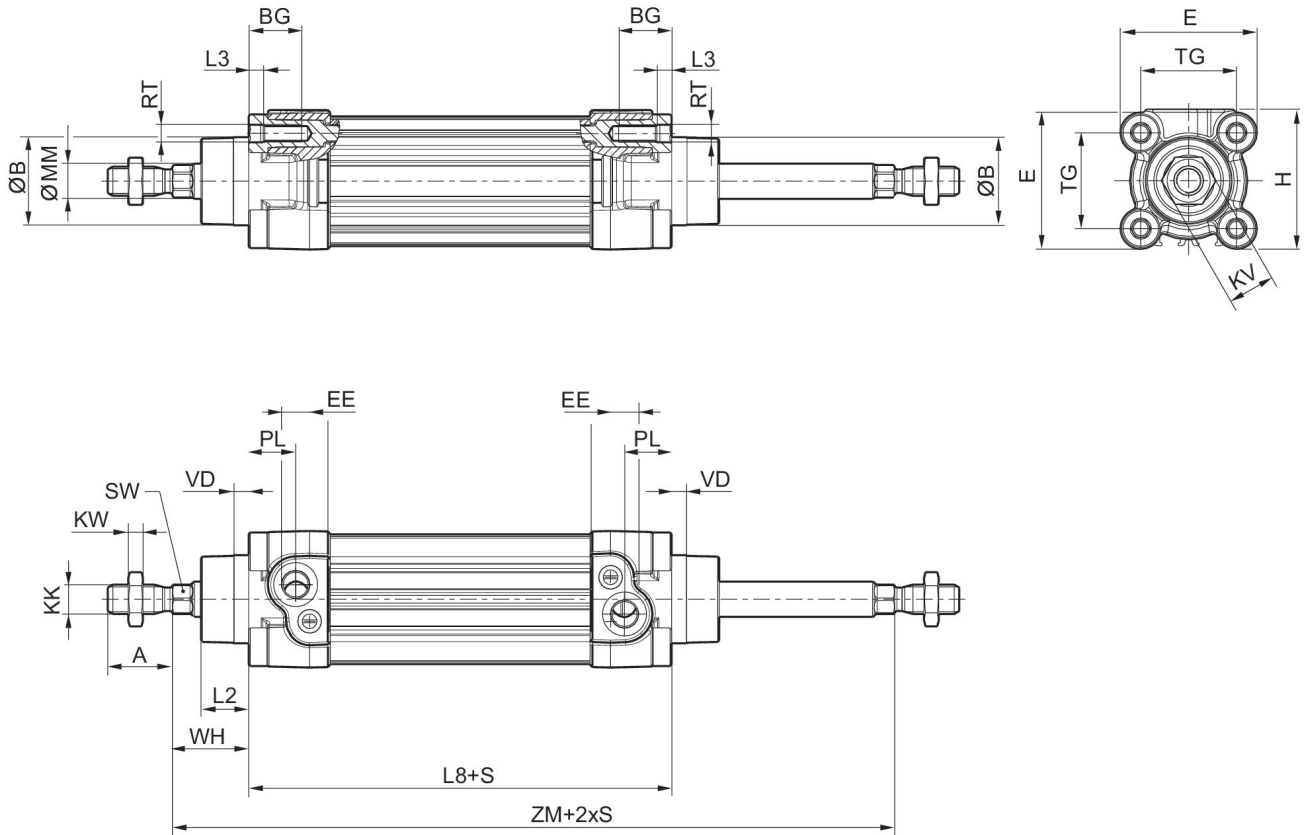

S = stroke

| Piston Ø | A -2 | ØB d11 | BG min. | E    | EE inch | EE    | H    | KK inch       | KK       |
|----------|------|--------|---------|------|---------|-------|------|---------------|----------|
| 32       | 22   | 30     | 16      | 46.5 | 1/8 NPT | G 1/8 | 47.5 | 7/16 - 20 UNF | M10x1,25 |
| 40       | 24   | 35     | 16      | 53   | 1/4 NPT | G 1/4 | 53   | 1/2 - 20 UNF  | M12x1,25 |
| 50       | 32   | 40     | 16      | 65   | 1/4 NPT | G 1/4 | 65   | 3/4 - 16 UNF  | M16x1,5  |
| 63       | 32   | 45     | 16      | 75   | 3/8 NPT | G 3/8 | 75   | 3/4 - 16 UNF  | M16x1,5  |
| 80       | 40   | 45     | 17      | 95   | 3/8 NPT | G 3/8 | 95   | 3/4 - 16 UNF  | M20x1,5  |
| 100      | 40   | 55     | 17      | 115  | 1/2 NPT | G 1/2 | 115  | 3/4 - 16 UNF  | M20x1,5  |
| 125      | 54   | 60     | 20      | 140  | 1/2 NPT | G 1/2 | 140  | 1 - 14 UNF    | M27x2    |

| Piston Ø | KV | KW   | ØMM f8 | PL   | L2    | L3 ±0,5 | L8      | RT  | SW |
|----------|----|------|--------|------|-------|---------|---------|-----|----|
| 32       | 16 | 5    | 12     | 16   | 16.25 | 4.5     | 94±0,4  | M6  | 10 |
| 40       | 18 | 6    | 16     | 20   | 18.25 | 4.5     | 105±0,7 | M6  | 13 |
| 50       | 24 | 8    | 20     | 19   | 25    | 4.5     | 106±0,7 | M8  | 17 |
| 63       | 24 | 8    | 20     | 24   | 25    | 4.5     | 121±0,8 | M8  | 17 |
| 80       | 30 | 10   | 25     | 23.5 | 33    | 0       | 128±0,8 | M10 | 22 |
| 100      | 30 | 10   | 25     | 25   | 36    | 0       | 138±1   | M10 | 22 |
| 125      | 41 | 13.5 | 32     | 33   | 45    | 0       | 160±1   | M12 | 27 |

# Profile cylinder ISO 15552, Series PRA - inch

R480176204

AVENTICS  
Series  
PRA Profile  
cylinders  
(ISO 15552)

2024-04-12

| Piston Ø | TG       | VD | WH     | ZM         |
|----------|----------|----|--------|------------|
| 32       | 32,5±0,5 | 5  | 26±1,4 | 146+3/-1,5 |
| 40       | 38±0,5   | 5  | 30±1,4 | 165+3/-1,5 |
| 50       | 46,5±0,6 | 5  | 37±1,4 | 180+3/-1,5 |
| 63       | 56,5±0,7 | 5  | 37±1,8 | 195+3/-1,5 |
| 80       | 72±0,7   | 5  | 46±1,8 | 220+3/-1,5 |
| 100      | 89±0,7   | 5  | 51±1,8 | 240+3,5/-2 |
| 125      | 110±1,1  | 7  | 65±2,2 | 290+3,5/-2 |

## Cushioning diagram



$v_t$  = Piston velocity [m/s]  $m$  = Cushionable mass [kg]

# Profile cylinder ISO 1552, Series PRA - inch

R480176204

AVENTICS  
Series  
PRA Profile  
cylinders  
(ISO 1552)

I-12

## Overview drawing



NOTE: This overview drawing is only for orientation to indicate where the various accessory parts can be fastened to the cylinder. The illustration has been simplified for this purpose. It is thus not possible to derive the dimensions from this overview.